

A *Nidec* Group Company

SERVO

All for dreams™



Motech
FANS AND BLOWERS

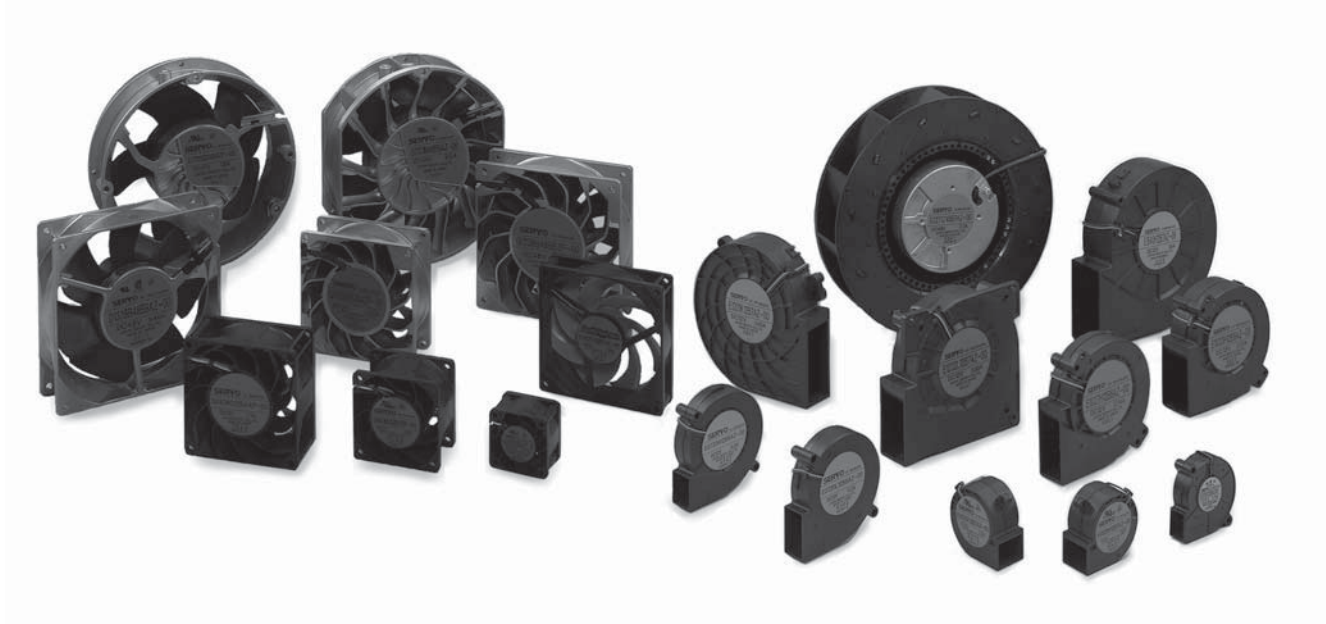

Fans & Blowers



CONTENTS

| | |
|---|------------|
| Contents | G-1 |
| Catalog Information | G-2 |
| Product Features of NIDEC SERVO Co. | G-3 |
| Motor Selection Guide | G-4 |
| Technical Data | G-6 |
| DC Axial Fans | G-16 |
| GentleTyphoon™ (NEW) | G-20, G-21 |
| Fixed Blade Type DC Axial Fans (NEW) | G-27 |
| (For a high static pressure region Fans G series) | |
| DC Centrifugal Blowers | G-30 |
| Variable-speed Fans and Blowers | G-41 |
| Customized Fans and Blowers | G-42 |
| AC Fans and Blowers | G-43 |
| Guards, Filters and Plug Cords (Options) | G-50 |

- Please visit our website for any technical inquiries or information.
- For non-technical inquiries, contact our local NIDEC SERVO sales office or distributor in your area.
- This catalog contains only the latest standard products in the inventory and semi-standard products.
Contact your NIDEC SERVO sales office or distributor for details about customized and semi-customized products.
- Please visit our website for specifications and other information on former products release.
- The dimensions, specifications, and components contained in this catalog are subject to change without prior notice due to further product improvements.
- Contact NIDEC SERVO Co. or a distributor if you wish to obtain product samples.

■ Catalog Information Guide

The descriptions of the AC and DC fans and blowers appear on the product pages as shown below. Contact NIDEC SERVO if clarification or further information is desired.

Lineup of standard products and basic characteristics.

Fan/blower noise in free air state. (Static pressure 0 Pa)
(This value is sometimes considerably higher when the fan or blower is installed in your equipment. See pages G-8 to G-10)

Operable voltage range.
(PQ characteristics vary depending on the operating voltage. See page G-7)

Startup current value.
(Use to select the power source)

Current value in free air state.
(The current at the operating point will be an increment of 20% or less of the rating with fans and will be below the rating with blowers. See page G-13)

Important notes regarding the basic characteristics.
List of products which do not meet the standard life.

Flange shape.
(Select ribbed specification when screws are used)

External dimensions, lead wire specifications.

Mounting hole dimensions as examples for fan mounting.
(Recommended shapes to maximize fan performance characteristics)

Customizing, safety standards, 3D data.

Product photo, maximum performance, weight.

List of model codes.
(Product codes for which orders are accepted)

Materials used, carton specification.

PQ characteristics chart.
(Drawing an estimated ventilating resistance curve will determine the airflow at the operating point)

Wiring connection to the power source. (See page G-15 for the wiring connection to the sensors)

List of fans and blowers with sensors.

Brushless DC Fans & Blowers

KUDC Series □92 × 25 mm

DC Axial Fans KUDC

□92 (3.6") × 25 (1.0")
Max. airflow: 1.8 m³/min
Max. static pressure: 70 Pa
Mass: 100 g

Fan model code

| |
|------------|
| KUDC12B4 |
| KUDC12B4P |
| KUDC12B4S |
| KUDC12B4V |
| KUDC12B4VS |
| KUDC12D4 |
| KUDC12D4S |
| KUDC12D4V |
| KUDC12D4VS |
| KUDC12H7 |
| KUDC12H7P |
| KUDC12H7S |
| KUDC12U7 |
| KUDC12U7P |
| KUDC12U7S |
| KUDC12Z7 |
| KUDC12Z7P |
| KUDC12Z7S |
| KUDC12Z7V |
| KUDC12Z7VP |
| KUDC12Z7VS |
| KUDC24B4 |
| KUDC24B4P |
| KUDC24B4S |
| KUDC24B4V |
| KUDC24D4S |
| KUDC24D4V |
| KUDC24H7 |
| KUDC24H7P |
| KUDC24H7S |
| KUDC24H7V |
| KUDC24H7VS |
| KUDC42Z7 |
| KUDC42Z7P |

Standard specification (Lead wire type)

| Max. airflow m ³ /min | CFM | Max. static pressure Pa | inH ₂ O | Noise dB | Speed r/min | Input W | Voltage spec. Rated (V) | Use (V) | Current mA | Model code | Operating temp. range (°C) | |
|-------------------------------------|-----|----------------------------|--------------------|-------------|----------------|------------|----------------------------|-----------|---------------|------------|-------------------------------|-----------|
| 1.8 | 64 | 70 | 0.28 | 41.5 | 3450 | 4.2 | 12 | 7.2-13.8 | 350 | 680 | KUDC12U7 | KUDC12U7V |
| | | | | | | 4.8 | 24 | 12-27.6 | 200 | 680 | KUDC24U7 | KUDC24U7V |
| 1.66 | 59 | 60 | 0.24 | 39 | 3200 | 3.2 | 12 | 7.2-13.8 | 270 | 690 | KUDC12H7 | KUDC12H7V |
| | | | | | | 3.6 | 24 | 12-27.6 | 150 | 350 | KUDC24H7 | KUDC24H7V |
| 1.55 | 55 | 52 | 0.21 | 37 | 2950 | 3.0 | 12 | 7.2-13.8 | 250 | 550 | KUDC12Z7 | KUDC12Z7V |
| | | | | | | 3.3 | 24 | 12-27.6 | 140 | 320 | KUDC24Z7 | KUDC24Z7V |
| | | | | | | 3.5 | 48 | 24-55.2 | 70 | 150 | KUDC42Z7 | |
| 1.4 | 49 | 43 | 0.17 | 34 | 2750 | 2.9 | 24 | 12-27.6 | 130 | 240 | KUDC24B4 | KUDC24B4V |
| | | | | | | 4.8 | 24 | 12-27.6 | 60 | 130 | KUDC48B4 | |
| | | | | | | 1.4 | 12 | 8.4-13.8 | 110 | 240 | KUDC12D4 | KUDC12D4V |
| | | | | | | 1.3 | 24 | 14.4-27.6 | 60 | 110 | KUDC24D4 | KUDC24D4V |

General specification

Materials used: Venturi: ABS and PBT synthetic resins; Propeller: ABS and PBT synthetic resins; Bearing: Both side shielded ball bearing

Motor: Brushless DC motor, Protection type: Current shut off by detecting lock state, automatically reset

Common elec. spec. See pages G-11 and 12.

Standard crate: 70 to a crate of (450 × 380 × 300) mm, mass 7 kg

Standard airflow and static pressure characteristics (At rated voltage)

External dimensions

Mounting hole dimensions [example]

Wiring connection diagram

axial fan with sensor

| Rated vol. | Model code | Model code | Model code | Model code |
|------------|------------|------------|------------|------------|
| 12V | KUDC12D4S | KUDC12B4S | KUDC12Z7S | KUDC12H7S |
| | KUDC12D4V | KUDC12B4V | KUDC12Z7V | KUDC12H7V |
| | KUDC12D4VS | KUDC12B4VS | KUDC12Z7VS | KUDC12H7VS |
| | KUDC12D4VP | KUDC12B4VP | KUDC12Z7VP | KUDC12H7VP |
| 24V | KUDC24D4S | KUDC24B4S | KUDC24Z7S | KUDC24H7S |
| | KUDC24D4V | KUDC24B4V | KUDC24Z7V | KUDC24H7V |
| | KUDC24D4VS | KUDC24B4VS | KUDC24Z7VS | KUDC24H7VS |
| | KUDC24D4VP | KUDC24B4VP | KUDC24Z7VP | KUDC24H7VP |
| 48V | KUDC42Z7P | KUDC48B4P | | |

Notes: Japan Servo will gladly respond to customizing requirements, including connector processing to lead wire terminals, models with a sensor other than those models listed above and variable speed specification. Contact Japan Servo during the product planning/development stage. The listed products are registered in the following business standards: JIS, JIS-B, JIS-C, JIS-D, JIS-E, JIS-F, JIS-G, JIS-H, JIS-I, JIS-K, JIS-L, JIS-M, JIS-N, JIS-O, JIS-P, JIS-Q, JIS-R, JIS-S, JIS-T, JIS-U, JIS-V, JIS-W, JIS-X, JIS-Y, JIS-Z, JIS-AA, JIS-AB, JIS-AC, JIS-AD, JIS-AE, JIS-AF, JIS-AG, JIS-AH, JIS-AI, JIS-AJ, JIS-AL, JIS-AM, JIS-AN, JIS-AP, JIS-AQ, JIS-AR, JIS-AS, JIS-AT, JIS-AU, JIS-AV, JIS-AW, JIS-AX, JIS-AY, JIS-AZ, JIS-BA, JIS-BB, JIS-BC, JIS-BD, JIS-BE, JIS-BF, JIS-BG, JIS-BH, JIS-BI, JIS-BJ, JIS-BL, JIS-BM, JIS-BN, JIS-BO, JIS-BP, JIS-BQ, JIS-BR, JIS-BS, JIS-BT, JIS-BU, JIS-BV, JIS-BW, JIS-BX, JIS-By, JIS-BZ, JIS-CA, JIS-CB, JIS-CC, JIS-CD, JIS-CE, JIS-CF, JIS-CG, JIS-CH, JIS-CI, JIS-CJ, JIS-CK, JIS-CL, JIS-CM, JIS-CN, JIS-CP, JIS-CQ, JIS-CR, JIS-CS, JIS-CT, JIS-CU, JIS-CV, JIS-CW, JIS-CX, JIS-CY, JIS-CZ, JIS-DA, JIS-DB, JIS-DC, JIS-DD, JIS-DE, JIS-DF, JIS-DG, JIS-DH, JIS-DI, JIS-DJ, JIS-DK, JIS-DM, JIS-DN, JIS-DO, JIS-DP, JIS-DQ, JIS-DR, JIS-DS, JIS-DT, JIS-DU, JIS-DV, JIS-DW, JIS-DX, JIS-DY, JIS-DZ, JIS-EA, JIS-EB, JIS-EC, JIS-ED, JIS-EE, JIS-EF, JIS-EG, JIS-EH, JIS-EI, JIS-EJ, JIS-EK, JIS-EM, JIS-EN, JIS-EO, JIS-EP, JIS-EQ, JIS-ER, JIS-ES, JIS-ET, JIS-EU, JIS-EV, JIS-EW, JIS-EX, JIS-EY, JIS-EZ, JIS-FA, JIS-FB, JIS-FC, JIS-FD, JIS-FE, JIS-FF, JIS-FG, JIS-FH, JIS-FI, JIS-FJ, JIS-FK, JIS-FM, JIS-FN, JIS-FO, JIS-FP, JIS-FQ, JIS-FR, JIS-FS, JIS-FT, JIS-FU, JIS-FV, JIS-FW, JIS-FX, JIS-FY, JIS-FZ, JIS-GA, JIS-GB, JIS-GC, JIS-GD, JIS-GE, JIS-GF, JIS-GG, JIS-GH, JIS-GI, JIS-GJ, JIS-GK, JIS-GL, JIS-GM, JIS-GN, JIS-GO, JIS-GP, JIS-GQ, JIS-GR, JIS-GS, JIS-GT, JIS-GU, JIS-GV, JIS-GW, JIS-GX, JIS-GY, JIS-GZ, JIS-HA, JIS-HB, JIS-HC, JIS-HD, JIS-HE, JIS-HF, JIS-HG, JIS-HI, JIS-HJ, JIS-HK, JIS-HL, JIS-HM, JIS-HN, JIS-HO, JIS-HP, JIS-HQ, JIS-HR, JIS-HS, JIS-HT, JIS-HU, JIS-HV, JIS-HW, JIS-HX, JIS-HY, JIS-HZ, JIS-IA, JIS-IB, JIS-IC, JIS-ID, JIS-IE, JIS-IF, JIS-IG, JIS-IH, JIS-II, JIS-IJ, JIS-IK, JIS-IL, JIS-IM, JIS-IN, JIS-IO, JIS-IP, JIS-IQ, JIS-IR, JIS-IS, JIS-IT, JIS-IU, JIS-IV, JIS-IW, JIS-IX, JIS-IY, JIS-IZ, JIS-JA, JIS-JB, JIS-JC, JIS-JD, JIS-JE, JIS-JF, JIS-JG, JIS-JH, JIS-JI, JIS-JJ, JIS-JK, JIS-JL, JIS-JM, JIS-JN, JIS-JO, JIS-JP, JIS-JQ, JIS-JR, JIS-JS, JIS-JT, JIS-JU, JIS-JV, JIS-JW, JIS-JX, JIS-JY, JIS-JZ, JIS-KA, JIS-KB, JIS-KC, JIS-KD, JIS-KE, JIS-KF, JIS-KG, JIS-KH, JIS-KI, JIS-KJ, JIS-KK, JIS-KL, JIS-KM, JIS-KN, JIS-KO, JIS-KP, JIS-KQ, JIS-KR, JIS-KS, JIS-KT, JIS-KU, JIS-KV, JIS-KW, JIS-KX, JIS-KY, JIS-KZ, JIS-LA, JIS-LB, JIS-LC, JIS-LD, JIS-LE, JIS-LF, JIS-LG, JIS-LH, JIS-LI, JIS-LJ, JIS-LK, JIS-LM, JIS-LN, JIS-LO, JIS-LP, JIS-LQ, JIS-LR, JIS-LS, JIS-LT, JIS-LU, JIS-LV, JIS-LW, JIS-LX, JIS-LY, JIS-LZ, JIS-MA, JIS-MB, JIS-MC, JIS-MD, JIS-ME, JIS-MF, JIS-MG, JIS-MH, JIS-MI, JIS-MJ, JIS-MK, JIS-ML, JIS-MN, JIS-MO, JIS-MP, JIS-MQ, JIS-MR, JIS-MS, JIS-MT, JIS-MU, JIS-MV, JIS-MW, JIS-MX, JIS-MY, JIS-MZ, JIS-NA, JIS-NB, JIS-NC, JIS-ND, JIS-NE, JIS-NF, JIS-NG, JIS-NH, JIS-NI, JIS-NJ, JIS-NK, JIS-NL, JIS-NM, JIS-NO, JIS-NP, JIS-NQ, JIS-NR, JIS-NS, JIS-NT, JIS-NU, JIS-NV, JIS-NW, JIS-NX, JIS-NY, JIS-NZ, JIS-OB, JIS-OC, JIS-OD, JIS-OE, JIS-OF, JIS-OG, JIS-OH, JIS-OI, JIS-OJ, JIS-OK, JIS-OL, JIS-OM, JIS-ON, JIS-OO, JIS-OP, JIS-OQ, JIS-OR, JIS-OS, JIS-OT, JIS-OU, JIS-OV, JIS-OW, JIS-OX, JIS-OY, JIS-OZ, JIS-PA, JIS-PB, JIS-PC, JIS-PD, JIS-PE, JIS-PF, JIS-PG, JIS-PH, JIS-PI, JIS-PJ, JIS-PK, JIS-PL, JIS-PM, JIS-PN, JIS-PO, JIS-PP, JIS-PQ, JIS-PR, JIS-PS, JIS-PT, JIS-PU, JIS-PV, JIS-PW, JIS-PX, JIS-PY, JIS-PZ, JIS-QA, JIS-QB, JIS-QC, JIS-QD, JIS-QE, JIS-QF, JIS-QG, JIS-QH, JIS-QI, JIS-QJ, JIS-QK, JIS-QL, JIS-QM, JIS-QN, JIS-QO, JIS-QP, JIS-QQ, JIS-QR, JIS-QS, JIS-QT, JIS-QU, JIS-QV, JIS-QW, JIS-QX, JIS-QY, JIS-QZ, JIS-RA, JIS-RB, JIS-RC, JIS-RD, JIS-RE, JIS-RF, JIS-RG, JIS-RH, JIS-RI, JIS-RJ, JIS-RK, JIS-RL, JIS-RO, JIS-RR, JIS-RS, JIS-RT, JIS-RU, JIS-RV, JIS-RW, JIS-RX, JIS-RY, JIS-RZ, JIS-SA, JIS-SB, JIS-SC, JIS-SD, JIS-SE, JIS-SF, JIS-SG, JIS-SH, JIS-SI, JIS-SJ, JIS-SK, JIS-SL, JIS-SM, JIS-SN, JIS-SO, JIS-SP, JIS-SQ, JIS-SR, JIS-SS, JIS-ST, JIS-SU, JIS-SV, JIS-SW, JIS-SX, JIS-SY, JIS-SZ, JIS-TA, JIS-TB, JIS-TC, JIS-TD, JIS-TE, JIS-TF, JIS-TG, JIS-TH, JIS-TI, JIS-TJ, JIS-TK, JIS-TL, JIS-TM, JIS-TN, JIS-TO, JIS-TP, JIS-TQ, JIS-TR, JIS-TS, JIS-TT, JIS-TU, JIS-TV, JIS-TW, JIS-TX, JIS-TY, JIS-TZ, JIS-UA, JIS-UB, JIS-UC, JIS-UD, JIS-UE, JIS-UF, JIS-UG, JIS-UH, JIS-UI, JIS-UJ, JIS-UK, JIS-UL, JIS-UM, JIS-UN, JIS-UO, JIS-UP, JIS-UQ, JIS-UR, JIS-US, JIS-UT, JIS-UU, JIS-UV, JIS-UW, JIS-UX, JIS-UY, JIS-UZ, JIS-VA, JIS-VB, JIS-VC, JIS-VD, JIS-VE, JIS-VF, JIS-VG, JIS-VH, JIS-VI, JIS-VJ, JIS-VK, JIS-VL, JIS-VM, JIS-VN, JIS-VO, JIS-VP, JIS-VQ, JIS-VR, JIS-VS, JIS-VT, JIS-VU, JIS-VV, JIS-VW, JIS-VX, JIS-VY, JIS-VZ, JIS-WA, JIS-WB, JIS-WC, JIS-WD, JIS-WE, JIS-WF, JIS-WG, JIS-WH, JIS-WI, JIS-WJ, JIS-WK, JIS-WL, JIS-WM, JIS-WN, JIS-WO, JIS-WP, JIS-WQ, JIS-WR, JIS-WS, JIS-WT, JIS-WU, JIS-WV, JIS-WX, JIS-WY, JIS-WZ, JIS-XA, JIS-XB, JIS-XC, JIS-XD, JIS-XE, JIS-XF, JIS-XG, JIS-XH, JIS-XI, JIS-XJ, JIS-XK, JIS-XL, JIS-XM, JIS-XN, JIS-XO, JIS-XP, JIS-XQ, JIS-XR, JIS-XS, JIS-XT, JIS-XU, JIS-XV, JIS-XW, JIS-XX, JIS-XY, JIS-XZ, JIS-YA, JIS-YB, JIS-YC, JIS-YD, JIS-YE, JIS-YF, JIS-YG, JIS-YH, JIS-YI, JIS-YJ, JIS-YK, JIS-YL, JIS-YM, JIS-YN, JIS-YO, JIS-YP, JIS-YQ, JIS-YR, JIS-YS, JIS-YT, JIS-YU, JIS-YV, JIS-YW, JIS-YX, JIS-YY, JIS-YZ, JIS-ZA, JIS-ZB, JIS-ZC, JIS-ZD, JIS-ZE, JIS-ZF, JIS-ZG, JIS-ZH, JIS-ZI, JIS-ZJ, JIS-ZK, JIS-ZL, JIS-ZM, JIS-ZN, JIS-ZO, JIS-ZP, JIS-ZQ, JIS-ZR, JIS-ZS, JIS-ZT, JIS-ZU, JIS-ZV, JIS-ZW, JIS-ZX, JIS-ZY, JIS-ZZ, JIS-AA, JIS-AB, JIS-AC, JIS-AD, JIS-AE, JIS-AF, JIS-AG, JIS-AH, JIS-AI, JIS-AJ, JIS-AL, JIS-AM, JIS-AN, JIS-AP, JIS-AQ, JIS-AR, JIS-AS, JIS-AT, JIS-AU, JIS-AV, JIS-AW, JIS-AX, JIS-AY, JIS-AZ, JIS-BA, JIS-BB, JIS-BC, JIS-BD, JIS-BE, JIS-BF, JIS-BG, JIS-BH, JIS-BI, JIS-BJ, JIS-BK, JIS-BL, JIS-BM, JIS-BN, JIS-BO, JIS-BP, JIS-BQ, JIS-BR, JIS-BS, JIS-BT, JIS-BU, JIS-BV, JIS-BW, JIS-BX, JIS-By, JIS-BZ, JIS-CA, JIS-CB, JIS-CC, JIS-CD, JIS-CE, JIS-CF, JIS-CG, JIS-CH, JIS-CI, JIS-CJ, JIS-CK, JIS-CL, JIS-CM, JIS-CN, JIS-CP, JIS-CQ, JIS-CR, JIS-CS, JIS-CT, JIS-CU, JIS-CV, JIS-CW, JIS-CX, JIS-CY, JIS-CZ, JIS-DA, JIS-DB, JIS-DC, JIS-DD, JIS-DE, JIS-DF, JIS-DG, JIS-DH, JIS-DI, JIS-DJ, JIS-DK, JIS-DM, JIS-DN, JIS-DO, JIS-DP, JIS-DQ, JIS-DR, JIS-DS, JIS-DT, JIS-DU, JIS-DV, JIS-DW, JIS-DX, JIS-DY, JIS-DZ, JIS-EA, JIS-EB, JIS-EC, JIS-ED, JIS-EE, JIS-EF, JIS-EG, JIS-EH, JIS-EI, JIS-EJ, JIS-EK, JIS-EM, JIS-EN, JIS-EO, JIS-EP, JIS-EQ, JIS-ER, JIS-ES, JIS-ET, JIS-EU, JIS-EV, JIS-EW, JIS-EX, JIS-EY, JIS-EZ, JIS-FA, JIS-FB, JIS-FC, JIS-FD, JIS-FE, JIS-FF, JIS-FG, JIS-FH, JIS-FI, JIS-FJ, JIS-FK, JIS-FM, JIS-FN, JIS-FO, JIS-FP, JIS-FQ, JIS-FR, JIS-FS, JIS-FT, JIS-FU, JIS-FV, JIS-FW, JIS-FX, JIS-FY, JIS-FZ, JIS-GA, JIS-GB, JIS-GC, JIS-GD, JIS-GE, JIS-GF, JIS-GG, JIS-GH, JIS-GI, JIS-GJ, JIS-GK, JIS-GL, JIS-GM, JIS-GN, JIS-GO, JIS-GP, JIS-GQ, JIS-GR, JIS-GS, JIS-GT, JIS-GU, JIS-GV, JIS-GW, JIS-GX, JIS-GY, JIS-GZ, JIS-HA, JIS-HB, JIS-HC, JIS-HD, JIS-HE, JIS-HF, JIS-HG, JIS-HI, JIS-HJ, JIS-HK, JIS-HL, JIS-HM, JIS-HN, JIS-HO, JIS-HP, JIS-HQ, JIS-HR, JIS-HS, JIS-HT, JIS-HU, JIS-HV, JIS-HW, JIS-HX, JIS-HY, JIS-HZ, JIS-IA, JIS-IB, JIS-IC, JIS-ID, JIS-IE, JIS-IF, JIS-IG, JIS-IH, JIS-II, JIS-IJ, JIS-IK, JIS-IL, JIS-IM, JIS-IN, JIS-IO, JIS-IP, JIS-IQ, JIS-IR, JIS-IS, JIS-IT, JIS-IU, JIS-IV, JIS-IW, JIS-IX, JIS-IY, JIS-IZ, JIS-JA, JIS-JB, JIS-JC, JIS-JD, JIS-JE, JIS-JF, JIS-JG, JIS-JH, JIS-JI, JIS-JJ, JIS-JK, JIS-JL, JIS-JM, JIS-JN, JIS-JO, JIS-JP, JIS-JQ, JIS-JR, JIS-JS, JIS-JT, JIS-JU, JIS-JV, JIS-JW, JIS-JX, JIS-JY, JIS-JZ, JIS-KA, JIS-KB, JIS-KC, JIS-KD, JIS-KE, JIS-KF, JIS-KG, JIS-KH, JIS-KI, JIS-KJ, JIS-KK, JIS-KL, JIS-KM, JIS-KN, JIS-KO, JIS-KP, JIS-KQ, JIS-KR, JIS-KS, JIS-KT, JIS-KU, JIS-KV, JIS-KW, JIS-KX, JIS-KY, JIS-KZ, JIS-LA, JIS-LB, JIS-LC, JIS-LD, JIS-LE, JIS-LF, JIS-LG, JIS-LH, JIS-LI, JIS-LJ, JIS-LK, JIS-LM, JIS-LN, JIS-LO, JIS-LP, JIS-LQ, JIS-LR, JIS-LS, JIS-LT, JIS-LU, JIS-LV, JIS-LW, JIS-LX, JIS-LY, JIS-LZ, JIS-MA, JIS-MB, JIS-MC, JIS-MD, JIS-ME, JIS-MF, JIS-MG, JIS-MH, JIS-MI, JIS-MJ, JIS-MK, JIS-ML, JIS-MN, JIS-MO, JIS-MP, JIS-MQ, JIS-MR, JIS-MS, JIS-MT, JIS-MU, JIS-MV, JIS-MW, JIS-MX, JIS-MY, JIS-MZ, JIS-NA, JIS-NB, JIS-NC, JIS-ND, JIS-NE, JIS-NF, JIS-NG, JIS-NH, JIS-NI, JIS-NJ, JIS-NK, JIS-NL, JIS-NM, JIS-NO, JIS-NP, JIS-NQ, JIS-NR, JIS-NS, JIS-NT, JIS-NU, JIS-NV, JIS-NW, JIS-NX, JIS-NY, JIS-NZ, JIS-OB, JIS-OC, JIS-OD, JIS-OE, JIS-OF, JIS-OG, JIS-OH, JIS-OI, JIS-OJ, JIS-OK, JIS-OL, JIS-OM, JIS-ON, JIS-OO, JIS-OP, JIS-OQ, JIS-OR, JIS-OS, JIS-OT, JIS-OU, JIS-OV, JIS-OW, JIS-OX, JIS-OY, JIS-OZ, JIS-PA, JIS-PB, JIS-PC, JIS-PD, JIS-PE, JIS-PF, JIS-PG, JIS-PH, JIS-PI, JIS-PJ, JIS-PK, JIS-PL, JIS-PM, JIS-PN, JIS-PO, JIS-PP, JIS-PQ, JIS-PR, JIS-PS, JIS-PT, JIS-PU, JIS-PV, JIS-PW, JIS-PX, JIS-PY, JIS-PZ, JIS-QA, JIS-QB, JIS-QC, JIS-QD, JIS-QE, JIS-QF, JIS-QG, JIS-QH, JIS-QI, JIS-QJ, JIS-QK, JIS-QL, JIS-QM, JIS-QN, JIS-QO, JIS-QP, JIS-QQ, JIS-QR, JIS-QS, JIS-QT, JIS-QU, JIS-QV, JIS-QW, JIS-QX, JIS-QY, JIS-QZ, JIS-RA, JIS-RB, JIS-RC, JIS-RD, JIS-RE, JIS-RF, JIS-RG, JIS-RH, JIS-RI, JIS-RJ, JIS-RK, JIS-RL, JIS-RO, JIS-RR, JIS-RS, JIS-RT, JIS-RU, JIS-RV, JIS-RW, JIS-RX, JIS-RY, JIS-RZ, JIS-SA, JIS-SB, JIS-SC, JIS-SD, JIS-SE, JIS-SF, JIS-SG, JIS-SH, JIS-SI, JIS-SJ, JIS-SK, JIS-SL, JIS-SM, JIS-SN, JIS-SO, JIS-SP, JIS-SQ, JIS-SR, JIS-SS, JIS-ST, JIS-SU, JIS-SV, JIS-SW, JIS-SX, JIS-SY, JIS-SZ, JIS-TA, JIS-TB, JIS-TC, JIS-TD, JIS-TE, JIS-TF, JIS-TG, JIS-TH, JIS-TI, JIS-TJ, JIS-TK, JIS-TL, JIS-TM, JIS-TN, JIS-TO, JIS-TP, JIS-TQ, JIS-TR, JIS-TS, JIS-TT, JIS-TU, JIS-TV, JIS-TW, JIS-TX, JIS-TY, JIS-TZ, JIS-UA, JIS-UB, JIS-UC, JIS-UD, JIS-UE, JIS-UF, JIS-UG, JIS-UH, JIS-UI, JIS-UJ, JIS-UK, JIS-UL, JIS-UM, JIS-UN, JIS-UO, JIS-UP, JIS-UQ, JIS-UR, JIS-US, JIS-UT, JIS-UU, JIS-UV, JIS-UW, JIS-UX, JIS-UY, JIS-UZ, JIS-VA, JIS-VB, JIS-VC, JIS-VD, JIS-VE, JIS-VF, JIS-VG, JIS-VH, JIS-VI, JIS-VJ, JIS-VK, JIS-VL, JIS-VM, JIS-VN, JIS-VO, JIS-VP, JIS-VQ, JIS-VR, JIS-VS, JIS-VT, JIS-VU, JIS-VV, JIS-VW, JIS-VX, JIS-VY, JIS-VZ, JIS-WA, JIS-WB, JIS-WC, JIS-WD, JIS-WE, JIS-WF, JIS-WG, JIS-WH, JIS-WI, JIS-WJ, JIS-WK, JIS-WL, JIS-WM, JIS-WN, JIS-WO, JIS-WP, JIS-WQ, JIS-WR, JIS-WS, JIS-WT, JIS-WU, JIS-WV, JIS-WX, JIS-WY, JIS-WZ, JIS-XA, JIS-XB, JIS-XC, JIS-XD, JIS-XE, JIS-XF, JIS-XG, JIS-XH, JIS-XI, JIS-XJ, JIS-XK, JIS-XL, JIS-XM, JIS-XN, JIS-XO, JIS-XP, JIS-XQ, JIS-XR, JIS-XS, JIS-XT, JIS-XU, JIS-XV, JIS-XW, JIS-XX, JIS-XY, JIS-XZ, JIS-YA, JIS-YB, JIS-YC, JIS-YD, JIS-YE, JIS-YF, JIS-YG, JIS-YH, JIS-YI, JIS-YJ, JIS-YK, JIS-YL, JIS-YM, JIS-YN, JIS-YO, JIS-YP, JIS-YQ, JIS-YR, JIS-YS, JIS-YT, JIS-YU, JIS-YV, JIS-YW, JIS-YX, JIS-YY, JIS-YZ, JIS-ZA, JIS-ZB, JIS-ZC, JIS-ZD, JIS-ZE, JIS-ZF, JIS-ZG, JIS-ZH, JIS-ZI, JIS-ZJ, JIS-ZK, JIS-ZL, JIS-ZM, JIS-ZN, JIS-ZO, JIS-ZP, JIS-ZQ, JIS-ZR, JIS-ZS, JIS-ZT, JIS-ZU, JIS-ZV, JIS-ZW, JIS-ZX, JIS-ZY, JIS-ZZ

High customer satisfaction achieved thanks to our quiet and energy efficient products with unsurpassed reliability and customizability.

Focusing on product development for computer related equipment, the compact axial fans from NIDEC SERVO are the result of technological innovations that minimize noise to the greatest possible extent.

NIDEC SERVO's product designs incorporate several industry firsts, including specially molded 3-dimensional blades, and GentleTyphoon fans with a unique blade shape. Market requirements are always researched and catered to in advance; meaning customers always receive products that perform well ahead of market rivals.

**● Versatile lineups of axial fans and centrifugal blowers
Fans for high static pressure applications are also supplied as standard products.**

The aerodynamic characteristics required for fan motors differ depending on the equipment in which they are installed, but may roughly be grouped into airflow focus and pressure focus types respectively. The axial fans and centrifugal blowers (also called "centrifugal fans" and "sirocco fans"), as fan motors of NIDEC SERVO, fall into both the former and latter categories. Recently, NIDEC SERVO has also developed pressure focus type axial fans, suitable for use in high static pressure regions, in response to diverse customer requirements.

As its name implies, an axial fan generates airflow in the motor axial direction. Airflow can be generated cylindrically by the propeller from the entire diameter of the fan, allowing considerable airflow generation. The axial fan sucks in air and pushes it out through the propeller blades, without large pressure (static pressure) output.

The centrifugal blower, on the other hand, recovers the airflow released by the impeller blades in a centrifugal direction from the motor shaft center via the scroll casing (also called a "housing" or "frame") and discharges it unidirectionally. This system effectively converts a centrifugal force into pressure, increasing the pressure (static pressure) to blow the air. However, only a limited airflow passes through the impeller, preventing a large airflow from being obtained.

NIDEC SERVO refers to the former as fans and the latter as blowers, to easily distinguish the differences between the two types.

In addition to these two types, NIDEC SERVO has recently released axial fans with features resembling those of the blower (high static pressure region fans, e.g. the G1751M series). These fans are attracting the attention of the IT industry and are highly rated as quiet products, capable of saving energy with high-impedance equipment, with which conventional axial fans have not been efficient.

● Our ceaseless quest to reduce noise

NIDEC SERVO continues to introduce a never ending series of quiet products to the market. People know to talk to NIDEC SERVO if low noise is a priority, and that reputation has grown over many years. Day and night, NIDEC SERVO is active in the research and development of low noise technology. NIDEC SERVO also swiftly introduced computational fluid dynamics (CFD) to deliver quiet fans and blowers that customers can use without worrying about designing noise reduction measures into their application.

● Versatile lineup of energy saving products

The power consumption of fans may be problematic with some high airflow products and with large fans and blowers. When several units are used, a high capacity power source must be installed. NIDEC SERVO markets a large variety of high-efficiency fan motors that can reduce the power capacity required for such machines.

● Only highly reliable products are delivered to customers

With product liability in mind, it is the logical responsibility of manufacturers to supply highly reliable products that can be used by customers without any product safety worries. Products with new designs are only supplied to the market after their viability has been verified by subjecting them to various reliability tests and proving that they are problem-free. Moreover, only high-reliability parts are used in the drive circuits of DC fans and blowers. NIDEC SERVO develops and designs products by specifying the strictest derating level in the industry.

● Customized and semi-customized product specifications

Products are supplied in optimum customized form for bulk purchases. NIDEC SERVO is capable of swiftly accomplishing optimum designs by fully exploiting CFD technology. NIDEC SERVO will propose optimum semi-customized fans and blowers by combining its large variety of customized parts. Let NIDEC SERVO devise a suitable solution to meet your requirements.

● All NIDEC SERVO catalog products conform to the EU RoHS Directive

All NIDEC SERVO products conform to the EU RoHS Directive by restricting the contents of six specified hazardous substances (lead, mercury, cadmium, hexavalent chromium, PBD and PBDE) to below tolerable values. (All products produced from the beginning of January 2006 meet the RoHS Directive. Certain standard inventory products may include those produced in and before December 2005. Please specify in your purchase orders that only RoHS-compliant products should be shipped.)

NIDEC SERVO is also active in reducing another 18 hazardous substances.

● AC and DC fans

One of the prominent advantages of AC fans is the fact that they can be directly connected to an AC power supply. The DC fan boasts high motor efficiency and is power-saving, as well as generating less heat, allowing the weight of the motor and venturi case to be reduced.

AC fans and blowers use AC induction motors and are suitable for constant speed operation. DC fans and blowers, meanwhile, use DC brushless motors and can have highly variable airflow. By varying the voltage supply, the speed is also easily adjustable. Standard DC fans and blowers regulated by variable-speed control are also available. See pages G-41 for further details.

[Principal applications]

- Computers and peripheral terminal equipment ● Servers
- Personal computers ● Copiers ● Audio equipment
- Broadcasting equipment ● Communication equipment
- Industrial equipment ● Medical equipment ● Game machines

Fans



Fan Characteristics

- Large airflow
- Linear intake and outlet
- Suitable for equipment with small ventilation resistance

Blowers



Blower Features

- High static pressure
- Right angle intake and outlet
- Suitable for equipment requiring local cooling and with large ventilation resistance.

Selection from external dimensions and max. airflow

● See 3D data of DC fans and blowers in the electronic catalog distributed separately or at the web2-CAD site (<http://www.web2cad.co.jp/>).

| AC/DC | External Dimensions mm (inch) | Series | Page in Catalog | Max. airflow (m ³ /min) | | | | | | | | | | | | | |
|-------|-------------------------------|-------------------------|-----------------|------------------------------------|---|---|---|---|---|---|---|---|----|----|----|----|----|
| | | | | 1 | 2 | 3 | 4 | 5 | 6 | 7 | 8 | 9 | 10 | 11 | 12 | 13 | 14 |
| DC | □60 x 25 (□2.4" x 1.0") | TUDC | G-16 | ■ | | | | | | | | | | | | | |
| DC | □80 x 25 (□3.2" x 1.0") | PUDC | G-17 | | ■ | | | | | | | | | | | | |
| DC | □92 x 25 (□3.6" x 1.0") | D0925C (Gentle Typhoon) | G-18 | | | ■ | | | | | | | | | | | |
| DC | □92 x 32 (□3.6" x 1.3") | KLDC | G-19 | | | | ■ | | | | | | | | | | |
| DC | □92 x 38 (□3.6" x 1.5") | G0938B | G-27 | | | | | ■ | | | | | | | | | |
| DC | □120x 25 (□4.7" x 1.0") | D1225C (Gentle Typhoon) | G-20 | | | ■ | | | | | | | | | | | |
| DC | □120x 25 (□4.7" x 1.0") | D1225C (Gentle Typhoon) | G-21 | | | | ■ | | | | | | | | | | |
| DC | □120 x 38 (□4.7" x 1.5") | CNDC | G-22 | | | | | ■ | | | | | | | | | |
| DC | □120 x 38 (□4.7" x 1.5") | D1238B | G-23 | | | | | | ■ | | | | | | | | |
| DC | □119 x 38 (□4.7" x 1.5") | G1238B (G series) | G-28 | | | | | | | ■ | | | | | | | |
| DC | □127 x 38 (□5.0" x 1.5") | D1338B | G-24 | | | | | | | | ■ | | | | | | |
| DC | φ 172[x150]x51(6.8[6.0])x2.0) | D1751M/D1751S | G-25/G-26 | | | | | | | | | ■ | | | | | |
| DC | φ 172[x150]x51(6.8[6.0])x2.0) | G1751M | G-29 | | | | | | | | | | ■ | | | | |
| AC | □80 x 25 (□3.2" x 1.0") | VE | G-43 | ■ | | | | | | | | | | | | | |
| AC | □92 x 25 (□3.6" x 1.0") | WE | G-44 | | ■ | | | | | | | | | | | | |
| AC | □92x 38 (□3.6" x 1.5") | KA | G-45 | | | ■ | | | | | | | | | | | |
| AC | □120 x 25 (□4.7" x 1.0") | CU | G-46 | | | | ■ | | | | | | | | | | |
| AC | □120 x 38 (□4.7" x 1.5") | CN | G-47 | | | | | ■ | | | | | | | | | |
| AC | φ 172[x150]x51(6.8[6.0])x2.0) | MA/PA | G-48/G-49 | | | | | | | | | | ■ | | | | |

■ Model code for DC fans and blowers (15-digit code)

■ Manufacturing lot No.

D 12 38 B 24 B 5 A Z - 00

9 A 25

- Customized code
 - 00: Standard type
 - A 01: Standard type (Model change product)
 - 04: 4P Terminal type
- Rotation sensor
 - S: Lock detection type
 - Q: Speed detection type
 - R: Speed detection type (Output reversion type)
 - P: Pulse output type
 - Z: No sensor (Standard type)
- Special code
 - A: Standard type
 - C: Higher moisture resistance
 - Y,Z: Variable speed
- Speed 1.2 ~ 9.A.B.C: Low ↔ High
- Bearings B: Ball bearing
- Voltage: 05: DC5 V 12: DC12 V 24: DC24 V 48: DC48 V
- Frame type
 - B: Square metal venturi
 - C: Square resin venturi with ribs
 - D: Square resin venturi without ribs
 - E: Black painted type B
 - S: Round metal venturi
 - T: Round plastic venturi
- Thickness (as mm)
- Frame dimensions (as cm)
- Category
 - D: DC fan
 - E: DC blower
 - G: High static pressure DC fan

- Date manufactured
- Month manufactured: A ~ L = January ~ December
- Year manufactured (Last digit of year)

Characteristics of Fans and Blowers

■ Airflow - static pressure characteristics (PQ characteristics)

1. Pressure loss (Ventilating resistance)

A force to obstruct the flow of air (pressure loss) is generated when air is channeled onto equipment, due to the parts layout and the shape of the air stream inside the equipment. This phenomenon is called ventilating resistance (also called "system impedance" and "channel resistance"). Air meets only modest resistance when it moves straight ahead within a wide space. (Fig. 1) When air passes through a narrow space or when the direction of an airflow changes, the ventilating resistance increases. (Fig. 2) The ventilating resistance increases further unless an outlet path (or a circulation path) is provided because an airflow cannot be created.

Ventilating resistance is small

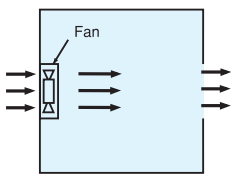

Fig. 1

Ventilating resistance is large

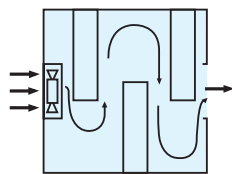

Fig. 2

2. Differences in PQ characteristics of fans and blowers

As illustrated in Fig. 3, the PQ characteristics exhibit characteristic trends when a motor of equivalent power is used. The fan has a large airflow and its static pressure is 1/2 to 1/5 that of the blower. The blower has large static pressure and its airflow is 1/2 to 1/5 that of the fan.

In the absence of a ventilating resistance (0 Pa), the max. airflow (QFmax) flows, under circumstances where there are no objects located around the fan (This free air condition is the x-axis). However, this condition does not exist as long as a fan is assembled in equipment. The state showing considerable ventilating resistance and a lack of airflow corresponds to the y-axis in Fig. 3 and the airflow is zero because the air does not move. In this condition, there are obstacles in front and to the rear of a fan that prevent airflow or that shut off the circulation path of the air. This operating condition cannot be considered when a fan is used for cooling or ventilation purposes. (Continuing operation in this condition may damage the fan.)

The actual operating conditions vary between the two aforementioned extremes. Fig. 3 plots four ventilating resistances (plotted via quadratic curves). Units of equipment containing either a fan or a blower have varying ventilating resistances, of which these four curves show typical examples. The airflow flowing into the equipment is at the intersection between the ventilating resistance curve and the PQ characteristics of the fan or the blower. The curve of Ventilating Resistance 1, which has the smallest inclination, is assumed to be the ventilating resistance of ordinary equipment. At this ventilating resistance, there are no large obstacles in front and to the rear of the fan and an adequate circulation path is provided. The fan can be operated most efficiently at this Ventilating Resistance 1, where about 80 % of the maximum fan airflow is possible. (Airflow of QF2 with a fan and of QB2 with a blower respectively)

Of the four curves, the airflow of any equipment that has Ventilating Resistance Curve 4, with the largest inclination, will be a fraction of the max. airflow, even though a high performance fan or blower is installed. In this condition, the airflow will be QB1 with a blower and QF1 with a fan, the airflow of the blower being larger.

The airflows of Ventilating Resistance Curves 2 and 3, in between, will also be airflows at the intersection with the respective PQ characteristics. NIDEC SERVO supplies fans dedicated to a high static pressure region, with fan motors optimally designed for intermediate ventilating resistances. As Fig. 4 explains, quieter and energy saving operations are more feasible in the high static pressure region compared with ordinary axial fans. (See page G-29)

By minimizing the ventilating resistance of the equipment and by using power-saving fans and blowers, both cost and noise reduction can be achieved, resulting in an ideal cooling solution. (Actual example: Ventilating resistance was reduced and quiet operation achieved by changing the thickness of a 92 square fan from 32 to 25 with equipment having densely mounted parts (Ventilating Resistance 3 in Fig. 4).

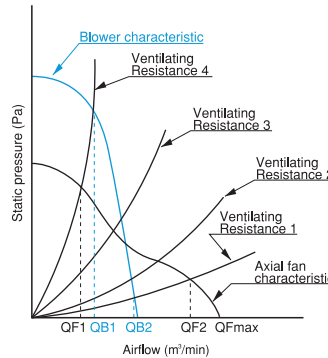

Fig. 3

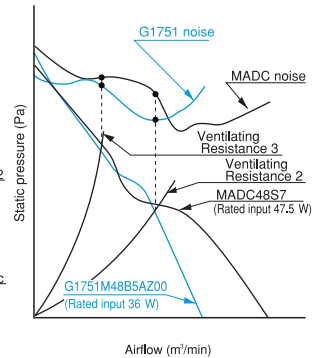

Fig. 4

3. Method for calculating the required fan airflow

The method to calculate the required airflows (ventilation rates) is described for the cooling of equipment which generates heat.

The airflow (ventilation rate) necessary for internal equipment cooling is calculated as follows: (Note: the entire heat is exhausted by ventilation airflow and heat from radiation or conduction is not taken into consideration)

$$Q = \frac{W}{\rho \times C \times \Delta T}$$

Q : Required airflow [m³/s]
 W : Heat generation rate [W]
 ρ : Specific weight of air [kg / m³]
 C : Specific heat of air [J / kg°C]
 ΔT : temperature rise of air [°C]

(ρ and C are values at 25 °C. Use the value 1100 instead of 1200 at 50 °C)

Example: When wishing to limit the air temperature rise inside equipment that generates 100 W of heat, the following calculation formula is used:

$$Q = \frac{100}{1200 \times 10} = 8.3 \times 10^{-3} \text{ m}^3 / \text{s} = 0.50 \text{ m}^3 / \text{min}$$

An airflow of 0.50 m³ / min or more is required. This calculation formula for the required airflows (ventilation rate) can be translated into a graph as shown in Fig. 5.

Air temperature rise and required airflow

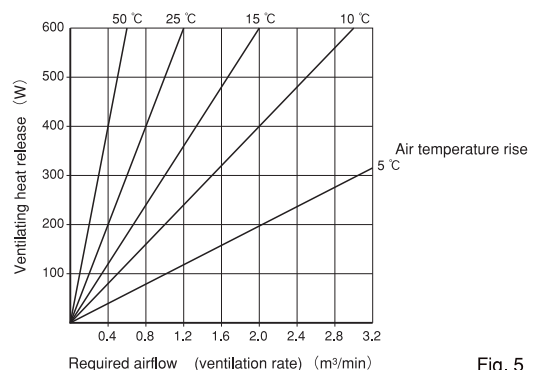
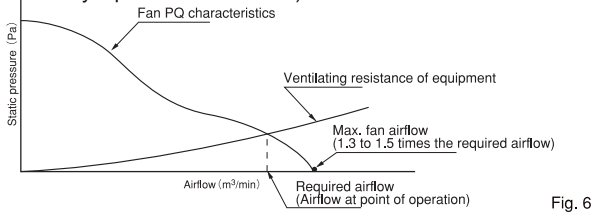

Fig. 5

4. Fan and blower selection

The required airflow and ventilating resistance of equipment must be determined when selecting a fan or a blower. However, accurate determination of a ventilating resistance is difficult. In general you can select a fan's max. airflow by multiplying the required airflow by 1.3 to 1.5. (The following figure [Fig. 6] shows the case of an air channel with an area approximately equal to that of the fan.)



If an adequate air channel is not available due to a high density of mounted parts, a fan with a max. airflow of more than two times the required airflow is sometimes needed. In this case, a special fan for a high static pressure region or a blower is recommended.

The following methods are used to accurately determine the ventilating resistance of equipment:

- 1) Send the equipment to a fan manufacturer and ask them to measure the ventilating resistance.
- 2) If 3D data of the equipment is available, ask the fan manufacturer to calculate the resistance.
- 3) Install a fan or a blower, whose relationship between the PQ characteristics and speed is already known, within the equipment and determine the ventilating resistance by measuring the speed.

5. PQ characteristics via the parallel or serial operations of 2 axial fans Parallel operation of 2 fans

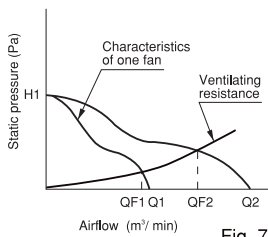

When two fans are operated in parallel, only the max. airflow will double. Intersections QF1 and QF2 with ventilating resistance curves of the equipment will be the airflow actually flowing. This mode is advantageous when wishing to increase the airflow of equipment with only modest ventilation resistance.

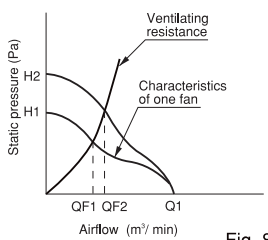

When two fans are operated in series (stacked), only the maximum static pressure will increase by 1.5 times. Intersections QF1 and QF2 with ventilating resistance curves of the equipment will be the airflow actually flowing.

ventilation resistance.

(Note: A fan specially designed for a high static pressure region will be further advantageous for equipment that has high ventilating resistance. [See Fig. 9.]

Serial operation of 2 fans with stationary blades for a high static pressure region

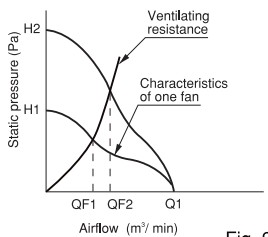

When two fans are run in series (stacked), only the maximum static pressure will increase by 1.8 to 2 times. NIDEC SERVO special fans for high static pressure regions have stationary blades and achieve a lower reduction in static pressure during serial operation. The intersections QF1 and QF2 with ventilating resistance curves of the equipment will be the airflows actually flowing.

6. Voltage imposed to fan and blower and PQ characteristics

DC powered fans and blowers have the following relationship between the imposed voltage and the PQ characteristics. The following information will be useful when fine tuning performance or when using a fan or a blower for experimental purposes:

(Note: Only test operation is allowed to be used outside of the specified voltage range. Note that this information is not applicable to AC powered fans, nor to certain DC fans. [Example: SADC fans] Please check the product information pages.)

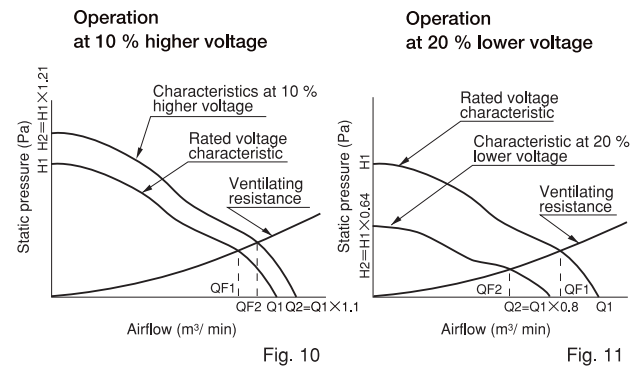

The speeds of fans and blowers vary in proportion of the voltage. Varying the voltage ± 10 % will also cause the speed to vary by ± 10 %. The speed affects the static pressure and airflow as follows. The static pressure varies based on the square of the speed and the airflow varies in proportion of the speed. Varying voltage ± 10 % will cause the maximum static pressure to vary -19 to +21%, and the max. airflow to vary ± 10 %. (See Fig. 10.)

An understanding of these relationships will allow free adjustment of the PQ characteristics during fan and blower operation.

7. Performance degradation of PQ characteristics when options are installed

Options such as a fan guard and filter are sometimes installed for safety. These options, however, increase the ventilation resistance and noise. A fan guard has slight ventilation resistance and degrades the PQ characteristics only negligibly. However, when tightly fitted onto a fan, the noise level increases by about +1 to +5 dB. In particularly, options should be installed more than 10 mm away from the fan to minimize the increase in noise.

Using a □120 mm × 38 mm AC fan (CN55B3) as an example, fluctuations of the PQ characteristics when options are installed are plotted in Figs. 12 and 13.

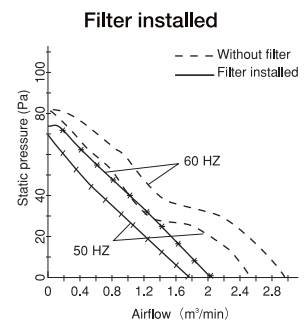
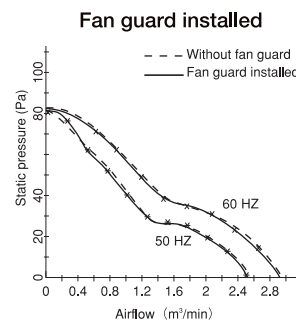

8. Unit conversion tables of PQ characteristics

At present, the PQ characteristics are expressed in Japan by Pa (static pressure) and m³/min (airflow). Use the following conversion tables for conversion between CFM, which is used in some countries, and between the units previously used in Japan.

Table 1 Static pressure conversion table

| Pa=N/m ² | mmHzO | inHzO | kgf/cm ² | atm | bar | lbf/in ² |
|----------------------|-----------------------|-----------------------|-----------------------|-----------------------|-----------------------|-----------------------|
| 1 | 1.02×10 ⁻¹ | 4.02×10 ⁻³ | 1.02×10 ⁻⁵ | 9.87×10 ⁻⁶ | 1.00×10 ⁻⁵ | 1.45×10 ⁻⁴ |
| 9.81 | 1 | 3.94×10 ⁻² | 1.00×10 ⁻⁴ | 9.68×10 ⁻⁵ | 9.80×10 ⁻⁵ | 1.42×10 ⁻³ |
| 2.49×10 ² | 25.4×10 ¹ | 1 | 2.54×10 ⁻³ | 2.46×10 ⁻³ | 2.49×10 ⁻³ | 3.61×10 ⁻² |
| 9.81×10 ⁴ | 1.00×10 ⁴ | 3.94×10 ² | 1 | 9.68×10 ¹ | 9.81×10 ¹ | 14.2×10 ¹ |
| 1.01×10 ⁵ | 1.03×10 ⁴ | 4.07×10 ² | 1.03 | 1 | 1.01 | 14.7×10 ¹ |
| 1.00×10 ⁵ | 1.02×10 ⁴ | 4.02×10 ² | 1.02 | 9.87×10 ⁻¹ | 1 | 14.5×10 ¹ |
| 6.9×10 ³ | 7.03×10 ² | 2.77×10 ¹ | 7.03×10 ⁻² | 6.81×10 ⁻² | 6.90×10 ⁻² | 1 |

Table 2 Airflow conversion table

| m ³ /s | m ³ /min | l/S | l/min | m ³ /h | ft ³ /S | CFM |
|-----------------------|-----------------------|-----------------------|----------------------|-----------------------|-----------------------|-----------------------|
| 1 | 6.00×10 ¹ | 1.00×10 ³ | 6.00×10 ⁴ | 3.60×10 ³ | 3.53×10 ¹ | 2.12×10 ³ |
| 1.67×10 ⁻² | 1 | 1.67×10 ¹ | 1.00×10 ³ | 6.00×10 ¹ | 5.89×10 ⁻¹ | 3.53×10 ¹ |
| 1.00×10 ⁻³ | 6.00×10 ⁻² | 1 | 6.00×10 ¹ | 3.60 | 3.53×10 ⁻² | 2.12 |
| 1.67×10 ⁻⁴ | 1.00×10 ⁻³ | 1.67×10 ⁻² | 1 | 6.00×10 ⁻² | 5.89×10 ⁻² | 3.53×10 ⁻² |
| 2.78×10 ⁻⁴ | 1.67×10 ⁻² | 2.78×10 ⁻¹ | 1.67×10 ¹ | 1 | 9.81×10 ⁻³ | 5.88×10 ⁻¹ |
| 2.83×10 ⁻² | 1.7 | 2.83×10 ¹ | 1.70×10 ³ | 1.02×10 ² | 1 | 6.00×10 ¹ |
| 4.72×10 ⁻⁴ | 2.83×10 ⁻² | 4.72×10 ⁻¹ | 2.83×10 ¹ | 1.70 | 1.67×10 ⁻² | 1 |

9. Measurement method of PQ characteristics

The aerodynamic characteristic measuring apparatus is illustrated in Fig. 14. This apparatus conforms to the ANSI/AMCA Standard 210-85, as well as JIS B 8330 (Testing methods for turbo-fans).

It is very difficult to measure PQ performance with high accuracy and the various measuring equipment used by fan manufacturers feature a wide range of accuracy. For this reason, simultaneous acquisition of comparable data obtained by the same measuring apparatus is recommended when verification of strict variation in performance is desired. (NIDEC SERVO also measures the comparative data of fans manufactured by other fan manufacturers as a customer service - please make use of this.)

Aerodynamic test apparatus (Double chamber type)

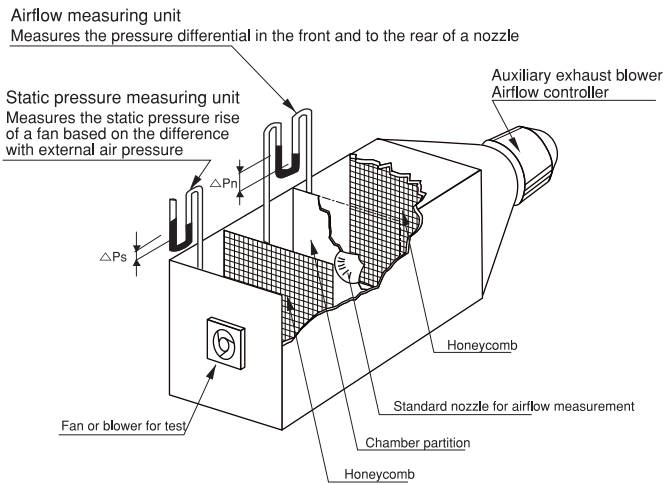

Fig. 14

Noise

1. Types of noise

Noise is generated by the combination of various conditions. Measures to eliminate or reduce noise can be taken more easily by analyzing the details of the noise.

When reducing the noise of your equipment, take into account the following factors that contribute toward noise generation:

| | | |
|-------------------|-------------------|--|
| Aerodynamic noise | Noise of rotation | Propeller sound · · · Sound emitted by the revolutions of blades Periodic flow fluctuations of flow · · · · · Interference and air separation with stationary blades, strut and venturi. |
| | Eddy flow sound | Turbulence in inflow flow, random eddy discharge from the eddy flow boundary layer on blade surfaces and air separation. |
| Mechanical noise | Vibration sound | Mechanical motor vibration sound · · · Imbalanced revolutions, resonance and vibration transfer sound. Electromagnetic sound of motor · · · · · Vibration sound by phase change (switching). |
| Cavity noise | | Air column resonance and other sounds |

2. Noise of fan

The noise of the fan itself (catalog noise) is measured in a small anechoic room, in which background noise is adequately low, in a free-air state with no objects surrounding the fan. The aerodynamic noise (blade sound) and motor sound are the principal noise sources.

3. Noise after installation in equipment

After installing the fan in your equipment the noise level sometimes increases drastically (up 8 dB to 15 dB) compared with the noise emitted by the fan itself. This is caused by the resonance of the fan vibration within the equipment, an obstacle in front of the intake (the fan guard may also become an obstacle), an increase in load noise due to ventilating resistance, the use of a fan with excessively large power, an insufficient circulation path, and other causes.

Noise can be reduced significantly by reducing the factors that increase noise. (In the best case scenario, only the noise level of the fan itself is generated)

NIDEC SERVO provides a service to analyze customers' equipment noise. Please contact NIDEC SERVO with your requirements.

4. Noise measurement

Noise is measured in accordance with the test method specified in JIS C 9603 Ventilating fans in Range A measurement, placed in a position 1 m in front of the intake side of fans and blowers. (Background noise 15 dB (A))

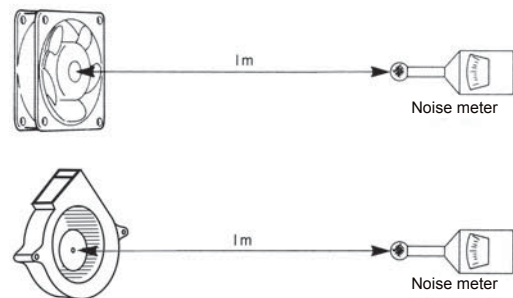

Fig. 15

5. Noise calculation

Noise is a sound pressure value measured in a position where the energy of a sound source arrives. It is called a sound pressure level (SPL) and is expressed in dB.

If the sound energy increases 10 times, the sound level increases 10 dB and 60 dB represents sound pressure energy that is 1000 times that of 30 dB and 10000 times that of 20 dB.

The total noise of several fans is calculated as follows:

$$\text{Total noise (L)} = 10 \log (10L^{1/10} + 10L^{2/10} + \dots + 10L^{n/10})$$

(Noise values of individual values are L1, L2 Ln)

Example: If four fans individually emit noise of 30 dB, 35 dB, 40 dB and 45 dB,

the total noise of the four fans will be:

$$L = 10 \log (10^{30/10} + 10^{35/10} + 10^{40/10} + 10^{45/10}) = 46.6 \text{ dB}$$

If all three fans emit 40dB, their total noise will be:

$$L = 10 \log (10^{40/10} + 10^{40/10} + 10^{40/10}) = 40 + 10 \log 3 = 44.8 \text{ dB}$$

The noise can be calculated from the following graph in Fig. 16 if the noise difference between two fans is 13 dB or less:

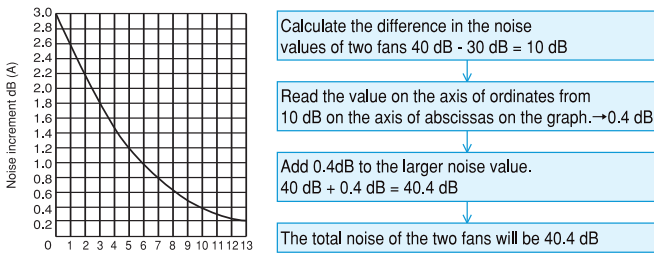

Difference in the noise values of two fans in dB (A)

Fig. 16

6. Speed and noise value

A fan's noise value is the total of the aerodynamic and motor noise. Most noise is aerodynamic in nature, except in products with a low speed.

The speed and noise value vary in proportion to the sixth power and the noise value increases when the speed increases. (Some people say that they vary in proportion to the fifth power.) Increasing the speed will double the max. airflow and quadruple the maximum static pressure. Noise increases 18.1 dB (+15 dB at the fifth power).

$$dB2 = dB1 + 60 \log (N2/N1)$$

dB1: Noise value when the speed is N1

dB2: Noise value when the speed is N2

| Speed | 2000 min ⁻¹ (Standard) | 2200 min ⁻¹ | 2600 min ⁻¹ | 3000 min ⁻¹ | 4000 min ⁻¹ |
|-------------|-----------------------------------|------------------------|------------------------|------------------------|------------------------|
| Noise value | 0 | +2.5 dB | +6.8 dB | +10.6 dB | +18.1 dB |

7. Propeller diameter and noise level

The fan noise is strongly linked to the propeller size. Comparing the noise of fans with equivalent speed, the noise theoretically varies to the seventh power of the propeller diameter as follows:

In reality, the propeller shape is not symmetric and calculations cannot be performed as explained in the theory. However, the noise value with equivalent airflow rate will be as shown in the following table, indicating that a larger fan will reduce noise. (Value calculated based on the theory that the airflow varies to the third power of the propeller diameter)

$$dB2 = dB1 + 70 \log (D2/D1)$$

dB1: Noise value when the speed is D1

dB2: Noise value when the speed is D2

| Propeller diameter | 55 mm | 75 mm | 86 mm | 114 mm (Standard) | 121 mm | 142 mm |
|-------------------------------------|----------|----------|----------|-------------------|---------|----------|
| Noise value with equivalent speed | -22.2 dB | -12.7 dB | -8.6 dB | 0 | +1.8 dB | +6.7 dB |
| Noise value with equivalent airflow | +34.8 dB | +20.0 dB | +13.5 dB | 0 | -2.8 dB | -10.5 dB |

8. Object distance and noise value

The noise value (SPL) decreases as the sound source becomes distant while the fan noise value varies in proportion to the square of the distance and can be expressed by the following formula: (When the reflection sound to nearby walls is ignored)

$$dB2 = dB1 - 20 \log (L2/L1)$$

dB1: Noise value when the distance from the sound source is L1

dB2: Noise value when the distance from the sound source is L2

| Distance from sound | 50 cm | 1 m (Standard) | 150 cm |
|---------------------|-------|----------------|---------|
| source Noise value | +6 dB | 0 | -3.5 dB |

9. Ventilating resistance and noise value

Fan manufacturers note the noise values in their catalogs assuming a free air condition (ventilating resistance 0). When fans are physically assembled in equipment, the ventilating resistance cannot be zero and the noise values listed in catalogs are for reference purposes only. A method used to estimate sound values when fans are assembled in equipment is described below.

A noise value at each point of the PQ characteristics is called "load noise" and fans and blowers have their own characteristics. (See Figs. 17 and 18.)

The load noise is the noise of the fan itself at the point of operation. Fan characteristics include a "neck" (dip) in the plotted curves. This dip is caused by turbulence in the airflow on the propeller surfaces and noise increases steeply between this part and a low airflow region.

The fan has an area where noise becomes lowest (region of higher airflow than the neck). The circulation path should be designed such as to reduce ventilating resistance. However, if the ventilating resistance cannot be reduced with any equipment after trying various ideas, the study of fans for a high static pressure region is recommended. These are fans that have been developed and designed to emit low noise in a high static pressure region compared with ordinary fans. (See Fig. 4 on pages G-6 and G-27 to G-29.)

As plotted in Fig. 18, the load noise of blowers generally varies only slightly, while trends in load noise differ from one product to another of the blower manufacturers. Even if the catalog values are the same, noise invariably varies at the same operating point.

The blowers manufactured by NIDEC SERVO are designed to emit the lowest noise at customers' operating points so that the customers can base catalog load noise values reliably as actual blower noise.

Load noise of fan (CNDC24B7)

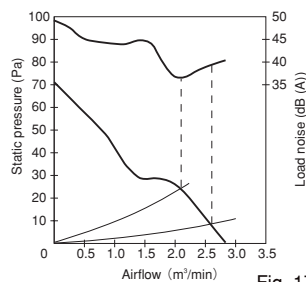

Fig. 17

Load noise of blower

(E1331K and SCBD [former model])

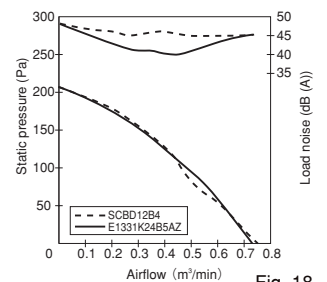

Fig. 18

10. Fan guards increase noise

When mounted directly onto a fan, a fan guard increases noise by about +1 to +5 dB. Install a fan guard more than 10 mm from equipment to reduce the increase in noise.

11. Equipment resonance with fan

The fan contains a motor that causes mechanical vibration and electrical vibration, which sometimes causes equipment containing a fan to resonate. This problem can be solved by combining the following three methods:

- 1) Cut off the vibration transfer route to equipment by providing a rubber vibration isolator or other cushioning.
- 2) Change the natural frequency of equipment by changing the board thickness or by other means.
- 3) Change to a low-vibration fan (customized product), in which case consult NIDEC SERVO for more information.

12. Quiet operation by Silent Fan

The rotating sound (blade sound) is the principal factor generating the noise of ordinary square axial fans.

The frequency characteristic of these fans peaks at the number of blades x speed and the related high frequency component. This is mainly caused by periodical fluctuations of blade lift due to non-uniform airflow (turbulence), caused by an object on the upstream side of the fan and attributed to the shape of the fan venturi.

The NIDEC SERVO Silent Fans, part of the range of axial fans with a unique venturi shape, are renowned for their particular quietness. To prevent non-uniform airflow on the upstream side of the fan, the venturi mounting flange has a single flange on the outlet side only, as illustrated in Fig. 19. The intake flow velocity and direction of the fan are made constant through analysis of the air intake flow to prevent separation of flow from the peripheral parts of the venturi, thereby achieving exceptional quietness. Thanks to the design preventing flow disturbance on the intake side when a fan is mounted, a premium silence effect unrivalled by conventional square fans is achieved.

Comparison of noise generating sources

● **Silent Fan**

Intake air flows in a fixed direction and at a constant flow velocity along the arc on the edge, hardly producing any noisy eddy turbulence.

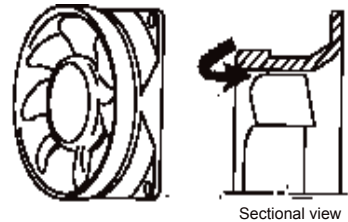

Fig. 19

● **Square Venturi Fan**

The airflow on the intake side is not constant. Differences in flow velocity and direction cause shear flow and trigger periodic lift fluctuations, leading to noise generation.

The air separation phenomenon occurs in the edge part, which is the thinnest part of the square venturi and round intake side, generating many eddy turbulences and increasing propeller resistance, thereby causing noise.

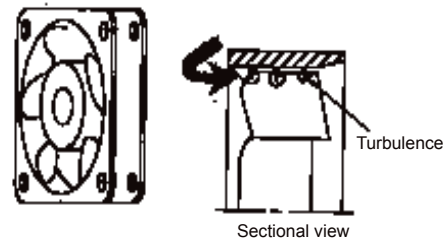

Fig. 20

13. The low-noise benefits you can get from our Gentle Typhoon. It has the perfect noise performance !

We at NIDEC Servo enhanced our Silent Fan Technology to bring you a brand new series called Gentle Typhoon in 2008. Designers can expect drastic noise reductions when building products with this fan.

Our Gentle Typhoon works to dampen noise in your products based on the combination of the propeller blades, which brings to mind spinning vortices of air and the square venturi which deters the occurrence of turbulence. Not only is the acoustic level improved, but so is overall noise quality.

The square shape offers compatibility conventional fans currently used by designers. Replace your current use fan for the Gentle Typhoon and experience a tranquil quieting of your next device. (18 and G-21)

Life of fans and blowers

The life of fans is solely dependent on bearings. The bearing load P in relation to the basic rated load C is $P \ll C$, (meaning P is a great deal smaller than C). Therefore we can say that grease life determines the fan life.

Grease life is significantly affected by ambient temperature. The fans of NIDEK SERVO feature a special design that minimizes grease temperature rises as illustrated below.

● AC fan

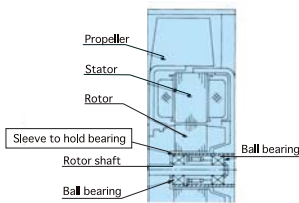

Fig. 21

● DC fan

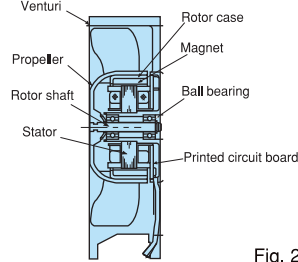

Fig. 22

■ Long-life structure

The fan motor contains two parts which generate heat, namely, the stator and rotor. The AC fan holds a bearing in a dedicated sleeve to help retard the transfer of heat generated by the rotor, and limit the temperature rises of the bearing.

The DC fan has an external rotor structure and the temperature of the bearing is significantly affected by stator temperature. When the speed rank rises, the motor temperature also rises, thereby increasing the heat transfer to the bearing. NIDEK SERVO fans feature a high-efficiency circuit and low motor losses to keep the bearing temperature below the preset temperature, thereby ensuring a long life.

The bearing temperature differs depending on the structure, materials and other factors and life varies to some extent. However, the life expectancy as illustrated in Fig. 23 is the basic data.

NIDEK SERVO accepts inquiries and orders for semi-customized products (long life products) featuring a reduction in bearing temperature increase. Please contact NIDEK SERVO for further information.

The life expectancy curve that is common to AC and DC fans is plotted in Fig. 23. (The curve represents the life expectancy based on a survival rate of 90 % and is not the guaranteed life. NIDEK SERVO will provide the MTTF (mean time to failure) data upon request.)

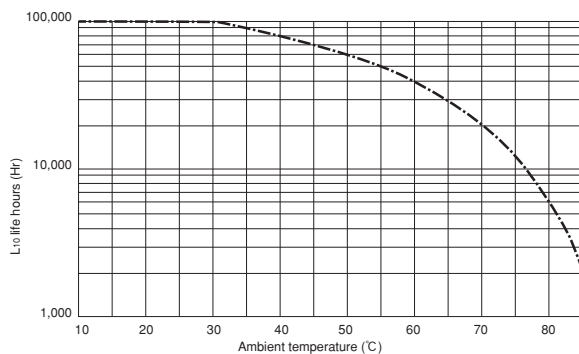

Fig. 23 Life expectancy curve (Survival rate 90 %)

(Note: This life expectancy curve has been prepared based on the results of life tests conducted at a rated voltage in a free air condition in an environmental test room with a negligible amount of dust. When using the fans in your application please take into consideration the actual operating conditions and safety factors. Some of the products contained in the catalogs do not meet the foregoing life expectancy data. [Products which do not meet the standard life are listed on the product information pages.]

(Definition of life: End of life is defined when the speed or noise of a product deteriorates by 20 %)

Applicable standards

NIDEK SERVO fans and blowers have been accepted in certification tests for Japanese and overseas safety standards for use in various applications. (Please inquire to NIDEK SERVO for standards that are not included in the following.)

◆ Electrical Appliance and Material Safety Law (Japan)

The AC fans that fall under the scope of the Electrical Appliance and Material Safety Law are manufactured in compliance with its technical standard. AC fans are classified as fans and blowers in one of 480 electrical appliance item categories other than specified electrical appliances. The marking of the (PS)E mark is a legal obligation. See page G-43 and subsequent pages for NIDEK SERVO products with the (PS)E mark. Power plug cords are classified as specified electrical appliances and the marking of the <PS> E mark is a legal obligation. (See page G-52.)

◆ Certification test by the UL Standard

NIDEK SERVO fans and blowers have been accepted in certification tests under the fan and blower safety test standard UL-507,73 of UNDERWRITERS LABORATORIES INC., the electrical appliance safety inspection organization of the United States. Products that are accepted in certification tests are marked with the mark on their nameplates and model names are registered, to attest that they are certified products. The registration No. of NIDEK SERVO is

- E 48889: Fans and blowers
 - E 78112: Plugs and cords
- (Category Nos. W1007, W1008)

Non-regular factory audits by UL are conducted in connection with the production of certified products and safety verification is performed by ensuring the materials used, electrical characteristics and other items pass strict factory test inspections.

◆ Certification test by the CSA Standard

NIDEK SERVO fans and blowers have been accepted in certification tests, based on general specification requirements and rules to prevent overheating inside motors under fan and blower safety test standard CSA STANDARDS C22.2 Nos. 113 and 0.077 of the CANADIAN STANDARDS ASSOCIATION, the electrical appliance safety inspection organization of Canada. Products that are accepted in certification tests are marked with the mark on their nameplates and model names are registered, to attest that they are certified products under the CSA standards.

The registration No. of NIDEK SERVO is
 LR49399: Made in Japan
 LR108118: Made in Indonesia

As with the UL standards, safety verification is performed by ensuring non-regular factory audits are performed by CSA. (Some products are certified by the mark.)

◆ Certification test by TUV

NIDEK SERVO fans and blowers have been accepted in safety certification tests based on the Business-Use Electrical Equipment Standard EN60950 and the VDE Standard No. 0806/08.81 of T RHEINLAND e.V, the industrial electrical appliance safety inspection organization of Germany. Products that are accepted in certification tests are marked with the mark on their nameplates and model names are registered, to attest that they are certified products under the TUV standards.

The registration Nos. of NIDEK SERVO are:

- LICENCE No.:R60299, R60300, R60301, R60302, R9451586
- :R9750695, R9750455, R9650662, R2-50004410
- REPORT No.:E61087, E61088, E61089, E61090

As under the UL and CSA standards, safety verification is performed by clearing non-regular factory audits by TUV.

◆ Certification test by VDE

NIDEC SERVO fans and blowers have been accepted in safety certification tests based on the Fan and Blower Safety Inspection Standard DIN VDE0700 of VERBAND DEUTSCHER ELEKTROTECHNIKER e.V, an electrical appliance safety inspection organization of Germany with the highest authority. Products that are accepted in certification tests are marked with the  mark on their nameplates and model names are registered, to attest that they are certified products under the VDE standards.

The registration No. of NIDEC SERVO is 3019.

As under the UL, CSA and TUV standards, safety verification is performed by clearing non-regular factory audits by VDE.

Common electrical specifications (Operational cautions)

● Insulation class

The insulation class of AC and DC fans and the blowers of NIDEC SERVO meet the heat resistance performance of Class E (120 °C) under JIS C 4004 (Rotating electrical machines - General), CLASS A (105 °C) under the UL-703 standard, CLASS A (105 °C) under the CSA-C22.2 standard, and DIN IEC950/VDE0806 standard and CLASS E (90 °C) under the VDE0700 standard.

● Dielectric strength

The AC fans and blowers of NIDEC SERVO satisfy 1500 V 50 Hz for one minute or 1800 V 50 Hz for one second. Dielectric strength tests under JIS C 4004 specify a voltage impression of "2 x rated voltage + 1000 V."

The DC fans and blowers of NIDEC SERVO are accepted in withstand voltage tests of 500 V 50 Hz for one minute or 600 V 50 Hz for one second. The interrupting current of 5 mA is set for the dielectric strength testers.

Dielectric strengths are tested between the power terminal of the fan/blower or lead wire conductor (two lead wires tied together) and metal frame (or other metal part) using a dielectric strength tester.

● Insulation resistance

The insulation resistance of the AC and DC fans and blowers of NIDEC SERVO is 10 MΩ or higher at 500 V DC between the power terminal or lead wire conductor and frame. Insulation resistance tests are conducted between the power terminal of the fan/blower or lead wire conductor (two lead wires tied together) and metal frame (or other metal part) using an insulation resistance tester.

● Electrical performance

The values described in the catalog are average values. Please request NIDEC SERVO to send a product drawing or delivery specification for products when wishing to confirm standard values.

● Temperature protection

Two methods are used to protect the temperature of the windings of AC fans and blowers, namely, impedance protection and thermal protection. These two methods are used differently depending on the type of motor used.

Impedance protection method

This method is generally used with shaded pole induction motors. Temperature increase is limited below a preset value by impedance (AC resistance) natural to the motor windings. In particular, the UL standard specifies that motors must not burn out when the rotor is operated for 18 days at normal temperature (24 °C). NIDEC SERVO fans and blowers meet this standard. Those products that are controlled by the Electrical Appliance and Material Safety Law of Japan are designed to limit coil temperature rises to less than 75 K.

The impedance protection method is effective only within the usage range. Note that smoke will be generated and ignition caused if a high voltage is imposed.

Thermal protection method

This method is used with motors of a capacitor phase advancing type or triple-phase induction motors. Embedding a bimetal switch with a contact in the motor winding part, the current is shut off when the preset winding temperature is exceeded, to prevent burning caused by abnormal overheating of the motor.

The windings of DC fans and blowers are protected against abnormal temperature rises by automatic reset, by shutting off the current if it detects a locked state or by current limiting automatic reset. This method involves the energizing circuit being turned off by a lock detection function inside the motor drive circuit when the fan is locked, shutting off (or limiting) the current.

Operation is reactivated automatically after the locking is reset. Note that this protection system does not function properly if used with duty (PWM) control power supply. NIDEC SERVO supplies variable-speed fans whose speed can be variably controlled by a PWM signal. (See pages G-27 to G-29, and G-41.)

Vital Precautions for DC Fans and Blowers

● Reverse connection protection

The DC fans and blowers embed a reverse connection protection circuit. Fans or blowers will not fail, even if connected in reverse within the usage range. (The fans or blowers will not activate, as no current flows to the circuit.)

● Yield strength to electrical noise

Yield strength to static noise: The yield strength between the lines or between a frame and line is 5 kV.

Yield strength to induced noise: Yield strength by an induced noise test apparatus is 2 kV.

Note 1: Malfunction of the sensor alarms will result if the induced noise exceeds 1 kV. Insert a 0.1 μF capacitor between the sensor line and ground as a precaution.

Note 2: Some of the products without a 15-digit product code cannot guarantee these yield strengths. Contact NIDEC SERVO for further information.

● Static electricity control

A static electricity measure is needed if a terminal trailing from the fan motor is touched, otherwise the circuit is prone to damage by static electricity.

● Handling of the alarm output lead wires

Inadvertently using a tester or other apparatus with a sensor lead wire will cause overcurrent to flow to the sensor circuit inside the motor, potentially causing a circuit fault. Pay attention to the permissible current and prevent any overcurrent from flowing. Contact NIDEC SERVO if it becomes necessary to connect an LED or relay directly to a sensor lead wire. (There are products that allow a current larger than the permissible current described on page G-15 depending on conditions.)

● Power supply selection for DC fans and blowers

Select a power source that supplies smooth power (ripples within ±5 %, peak within operating voltage). Significant line noise (including surge voltage) causes circuit faults. Make it a point to check line noise after assembling a fan.

Select a power source remembering that a current 2 to 5 times the rated current flows at startup. (If an inrush current [normally less than 10 μs] poses a problem, measure it and take action accordingly.)

The operating current peaks when the motor load is largest (at maximum static pressure for fans and in free air condition for blowers). When assembled, the current sometimes exceeds the rated current (fans) or smaller (blowers). (See the diagrams below.)

When current is flowing, connect all terminals from the fan motor before turning it on. Imperfect wiring connection or a wiring change while the power is turned on will damage the circuit inside the fan or cause it to deteriorate.

● Power ON and OFF of DC fans and blowers

Always perform ON-OFF control on the + side. ON - OFF control on the ground level causes circuit failure. ON-OFF control directly before a DC fan or a blower (between a fan and power supply) increases the risk of failures due to the counter-electromotive force from the motor coil. In this case, be sure to insert a diode or other device in parallel.

Surge voltage can sometimes be generated with DC fans and blowers due to a wiring condition or other reason, even if the power is turned off. Insert a diode or other device in parallel to the power lead wire when the equipment requires very high reliability.

(Recommended diode: With a capacity to withstand reverse voltage and a starting current 3 times the rated voltage)

● DUTY (PWM) control of DC fans and blowers

The locking protection circuit does not function properly if variable-speed operation is performed through DUTY (PWM [pulse width modulation]) control of the power lead wire using a speed controller sold on the market or other device. The alarm output does not function properly with fans that are installed with sensors. As mentioned earlier, caution should also be exercised with surge voltage that occurs during ON-OFF switching in DUTY control (out of guarantee.) Please note that this operating method increases fan vibration, increasing the likelihood of abnormal sounds due to vibration. Dedicated fans and blowers are recommended for variable-speed operations. (See pages G-27 to G29 and G-41.)

● Connect multiple DC fans and blowers in parallel

Connect multiple fans and blowers in parallel to the power supply. A serial connection (example: two 12 V products connected serially to a 24 V power supply) will cause the voltage for each product to fluctuate, resulting in a drastic excess of the usage range and circuit failure.

Please direct your questions or inquiries to NIDEC SERVO Sales or to the NIDEC SERVO website.

Example of fan operating current (SCNDM12B4)

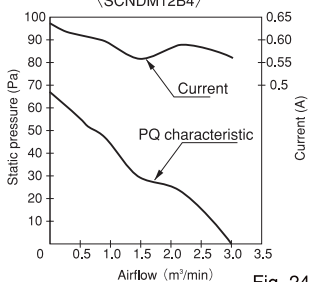

Fig. 24

Example of blower operating current (E1331K)

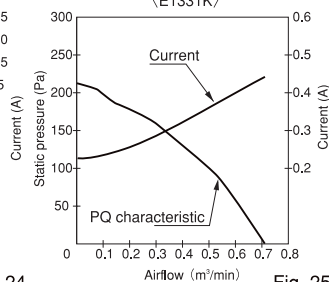

Fig. 25

Operational and handling precautions

Operational precautions

The products of NIDEC SERVO are designed and manufactured to be as versatile as possible. Nevertheless, exercise caution with the following:

1. Operating environment

- 1) Only highly durable flame-retardant resin is used. Nevertheless, avoid the presence of petroleum oil, such as cutting fluid and toxic gas from contact with resin sections of fans and blowers where such oil or gas is frequently used in operation by installing a filter or other apparatus. (If the operating environment cannot be improved, NIDEC SERVO will be glad to conduct a yield strength verification test upon receipt of fluid and other item/s. Consult NIDEC SERVO for more information.)
- 2) Open-type motors are used. The use of a fan or blower in a dusty place will adversely affect the circuit and ball bearings.
- 3) Avoid operating a fan or a blower in relative humidity exceeding 90 %.
- 4) The maximum storage temperature is normally 70 °C. Products with an operating temperature of 70 °C or higher can be operated only up to the specified temperature. Check the operating temperature range on the product information pages.
- 5) Exercise reasonable care with condensation when returning to an environment higher than 0 °C from storage or operating conditions below freezing point. Condensation results in failure and shortens the life.
- 6) The life may shorten considerably if a fan or a blower is installed in equipment that vibrates prominently. NIDEC SERVO products conform to JIS C 0040 (Vibration testing methods for small motors) and withstand a maximum vibration acceleration of 9.1 G maximum (10 Hz to 55 Hz, amplitude 1.5 mm, sweep 1 minute/cycle, two hours each in X, Y and Z directions). However, operation at 5 G or less is recommended.
- 7) AC and DC fans and blowers cannot be operated while the intake side is tightly closed. This will shorten the motor life and result in circuit failure.
- 8) Operation near a high frequency power source may on rare occasions cause inflow of an induced current into the inside of a fan, shortening the life (and increasing noise due to BB galvanic corrosion). If an induced current flows, measures to prevent such inflow are needed.

2. Imposed voltage and frequency

- 1) The permissible range of AC fans and blowers is ±10 % of the rated voltage. Operations outside of the rated frequency result in considerable fluctuations in performance and life. Operations in serial connection (example: two 100 V products connected serially to a 200 V power supply) will increase the imposed voltage beyond the permissible range and should be avoided.
- 2) Use a sufficiently smooth power supply with DC fans and blowers. (Ripples of ±5 % or less, and peak within the usage range) The usage range differs from one product to another. Check it on the product information pages.

3. Installation orientation

There are no installation orientation limitations for products containing ball bearings. Operate fans and blowers in compliance with the operating environment temperature and other conditions. Contact NIDEC SERVO for further information or if clarification is needed.

Handling precautions

The fan motors of NIDEC SERVO contain double side shielded precision ball bearings. Dropping the product could result in abnormal noise (Brinell dent) of ball bearings during operation. Exercise care when handling the products as follows:

1. Product falling: Avoid dropping the product from a height of 5 cm or higher.
2. Falling of crated product: Avoid dropping a crated product from a height of 30 cm or higher.
3. Storage and stacking of crated products: Crated products may be stacked up to seven layers. Take sufficient precautionary measures to prevent

getting them wet.

4. Do not apply a load of 2 kgf or more to the connecting part of the lead wire of a DC fan.

5. Fan installation: Exercise caution as follows when installing a fan on a panel or elsewhere.

- 1) Clamping of both flanges: The permissible tightening torque of M4 screws is 8 kgf · cm with an AC fan that has a metal venturi and up to 10 kgf · cm with a DC fan that has fan ribs. Through screws are not acceptable for the DC flange type. Use reinforcing spacers (for the KUDC and CNDC series) to tighten the double flanges on these products. (See page G-65.)
- 2) Clamping of single flange: The permissible tightening torque of screws when the installation surface is flat is 10 kgf · cm to 14 kgf · cm for both AC and DC fans.
- 3) Avoid contact with a propeller or impeller when mounting the intake side of fans and blowers. Excessive screw tightening will result in contact with a deformed venturi or housing.

Fan operational precautions

- Strive to ensure the channel shape is as smooth as possible to avoid stagnation in the airflow.
- Make the flow velocity larger around the object for which cooling is desired.
- Place the fan on the downstream side when wishing to cool the entire space inside the equipment.
- An upward flow in conjunction with the ascension of heated air is recommended for airflow inside equipment.
- Take actions to mitigate the impacts of fans and for reverse flow in the event of failure where multiple fans are installed.

1. When placing an object on the fan intake side, try to maintain a distance of more than half a blade diameter.

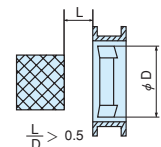

2. The pressure varies on the fan intake and outlet sides. The leakage of air from the outlet side causes noise. Minimize air leakage from the outlet side when installing a fan.

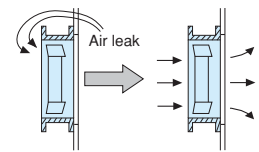

3. Design the channel (circulation path) selecting a good flow direction in terms of both noise and PQ characteristics.

• Ventilating resistance can be expressed by the following formula:

$$P = 0.000243Q^2 \sum_{i=1}^n \frac{1}{A_i^2}$$

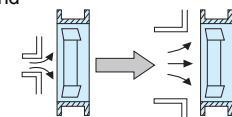

A reduction of A_i (the channel cross sectional area) is critical. Avoid any sharp change in the cross sectional area in the flow direction.

• Avoid any sharp change in flow direction.

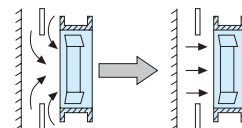

• Avoid placing a printed circuit board and other parts orthogonal to the flow direction.

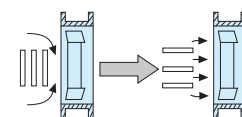

4. Drill fan mounting holes to ensure the smooth flow of air to reduce noise by referring to the recommended dimensions for fan mounting holes on the fan or blower's catalog page.

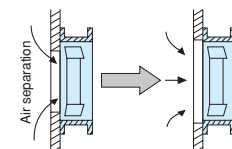

DC axial fans & blowers with sensors

The DC fans and blowers of NIDEK SERVO have a function to send an alarm signal when the fan motor revolutions slow down. Several systems are used to cut off the system power supply by this alarm signal, with three types of sensors available. Select the right type of sensor in accordance with the purpose of use. The lead wire for the sensor is yellow. The output type is an open collector output for all three types.

■ Sensor type

1. Lock detection type (Product code: S)

The output signal indicates an [L] state (transistor is ON) while the propeller is rotating, changing to an [H] state (transistor is OFF) less than five seconds after the propeller stops rotating. The propeller automatically restarts operation within five seconds when the lock is unlocked. ([H] → [L] 5 s). If the pull-up voltage is live, the [H] state (transistor is OFF) will engage in less than five seconds, even when the power is turned off.

- Specification: $V_{CE} = 28\text{ V max}$ (55.2 V max for 48 V products)
 $I_C = 5\text{ mA max}$
 $(V_{CE(SAT)} = 0.4\text{ V max})$
- Output waveform

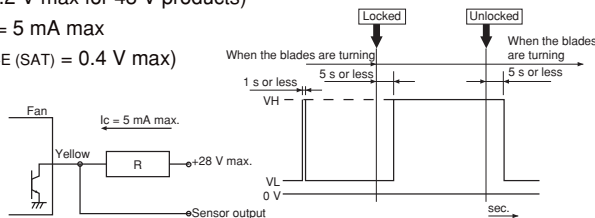

※When the power is turned on, the state sometimes becomes high [H] for several hundred ms.

2. Pulse output type (Product code: P)

A rectangular wave of two pulses will be output for each turn of the propeller while the propeller is rotating, outputting two types of signal depending on the propeller position when the propeller is locked. (See the note below ※)

- Specification: $V_{CE} = 28\text{ V max}$ (55.2 V max for 48 V products)
 $I_C = 5\text{ mA max}$
 $(V_{CE(SAT)} = 0.4\text{ V max})$
- Output waveform

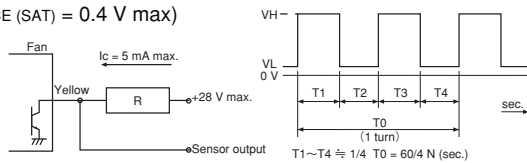

※Output signal waveform when the fan is stopped: The following two types of waveform are output, depending on the blade position when the propeller is stopped:
 Pulse outputs of High - constant or restart timing (0.05 Hz to 2 Hz).

3. Speed detection type (Product code: Q)

The output signal indicates the [H] state when the propeller revolutions are slower than the preset speed, changing to the [L] state when the propeller revolutions exceed the reset speed.

[Products with a reversed output waveform are also available, suitable for a wired OR connection when several fans are installed. Contact NIDEK SERVO for further information. {Former code: SQ, new code (15 - digit code products): R}]

- Specification: $V_{CE} = 28\text{ V max}$ (55.2 V max for 48 V products)
 $I_C = 5\text{ mA max}$
 $(V_{CE(SAT)} = 0.4\text{ V max at } 5\text{ mA})$
- Output waveform

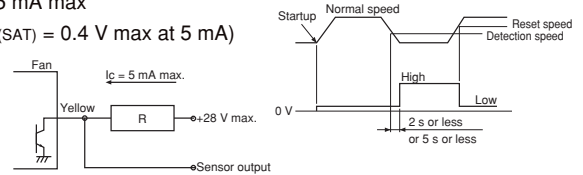

Note: The output waveform for type SQ (R) will be reversed.

The speed setting for the alarm output is about half the rated speed.

For more detailed information, please request a product delivery specification from NIDEK SERVO.

AC fans with sensors

By equipping the motor with a rotation detection function, the AC fans of NIDEK SERVO have a system to send an alarm signal when the fan motor revolutions slow down and to cut off the system power supply. In 1980, NIDEK SERVO developed a system to output an alarm signal by detecting the lowering of generated voltage by installing a tachometer generator with the cooling fan and this system has since been incorporated in NIDEK SERVO products. The output type of the alarm signal is an open collector output.

| Type | Tachometer generator type | | | |
|-------------------------|--|-----------------------|---|-----------------|
| Sensor output operation | Open collector transistor, permissible sync Current: 50 mA max. Permissible imposed voltage: DC 40 V max. Permissible power consumption: 1.5 W max. (at 25 °C) | | | |
| Sensor output operation | AC power supply | Speed | Output transistor operation | Output state |
| | OFF | | OPEN | HIGH (Abnormal) |
| | ON | Below detection speed | OPEN | HIGH (Abnormal) |
| | ON | Above detection speed | CLOSE | LOW (Normal) |
| Detection speed RD | 1500 ~ 2200 rpm | | | |
| Detection delay time TD | 2 s or less 17 Type | | | |
| Type | Standard speed | | | |
| Insulation resistance | 10 M Ω or higher by a DC 500 V: Between the sensor lead and venturi | | | |
| Dielectric strength | Between the sensor lead and venturi | | No anomaly allowed after applying AC 500 V 50 Hz for 1 minute | |

■ Sensor specification

■ Operational and handling precautions

Operate fans and blowers at an ambient temperature of between -10 °C and 60 °C and relative humidity of less than 90 %. Latch output is not used so malfunction by electrical noise can be ruled out. However, note that the semiconductor devices in the internal circuitry may be damaged by electrical noise and high voltage. No delay circuit is provided so a trouble signal is output on startup. As when operating and handling the fan, exercise caution to avoid dropping and exposing the blower to shock and vibration.

■ Sensor connection



1. LED Display

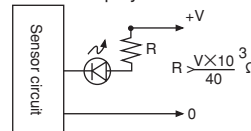

2. Relay operation

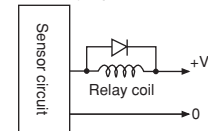

Use in tandem with a flyback diode. Limit the coil current to 50 mA or less.

※ A sensor is available with the AS ad PL series only.

DC Axial Fan

TUDC



□60×25 (□2.4"×1.0")
Max. airflow: 0.87 m³/min
Max. static pressure: 130 Pa
Mass: 75 g

Fan model code

- TUDC12B4
- TUDC12B4F
- TUDC12B4P
- TUDC12B4S
- TUDC12D4
- TUDC12D4F
- TUDC12D4Q
- TUDC12D4S
- TUDC12H4
- TUDC12H4P
- TUDC12H4S
- TUDC12H4SQ
- TUDC12N7
- TUDC12N7F
- TUDC12N7P
- TUDC12N7S
- TUDC12U7
- TUDC12U7P
- TUDC12U7S
- TUDC12Z4
- TUDC12Z4F
- TUDC12Z4FS
- TUDC12Z4P
- TUDC12Z4Q
- TUDC12Z4S
- TUDC24B4
- TUDC24B4F
- TUDC24B4S
- TUDC24D4
- TUDC24D4F
- TUDC24D4S
- TUDC24H4
- TUDC24H4F
- TUDC24H4P
- TUDC24H4S
- TUDC24N7
- TUDC24N7F
- TUDC24N7P
- TUDC24N7S
- TUDC24Z4
- TUDC24Z4F
- TUDC24Z4FS
- TUDC24Z4P
- TUDC24Z4Q
- TUDC24Z4S
- TUDC24Z4SQ
- TUDC48B4
- TUDC48B4P
- TUDC48B4S
- TUDC48H4
- TUDC48H4P
- TUDC48Z4
- TUDC48Z4FS
- TUDC48Z4P

Standard specification

| Max. Airflow | | Max. Static Pressure | | Noise dB | Speed min ⁻¹ | Input W | Voltage Spec. V | | Current mA | | Model Code | | Operating Temp. Range °C | |
|---------------------|-----|----------------------|--------------------|----------|-------------------------|---------|-----------------|-----------------|------------|----------|-------------|---------------|--------------------------|-----------|
| m ³ /min | CFM | Pa | inH ₂ O | | | | Rating | Operating Range | Rating | Starting | Open Flange | Ribbed Flange | | |
| 0.87 | 31 | 130 | 0.52 | 46 | 6800 | 4.2 | 12 | 7.2-13.8 | 350 | 1430 | TUDC12N7F | TUDC12N7 | -20 ~ +60 | |
| | | | | | | | 24 | 12-27.6 | 170 | 700 | TUDC24N7F | TUDC24N7 | | |
| 0.74 | 26 | 100 | 0.40 | 39 | 5700 | 2.5 | 12 | 6-13.8 | 210 | 790 | | TUDC12U7 | | -20 ~ +70 |
| | | | | | | | 24 | 12-27.6 | 110 | 360 | TUDC24H4F | TUDC24H4 | | |
| 0.65 | 23 | 75 | 0.30 | 37 | 5000 | 2.6 | 12 | 7.2-13.8 | 220 | 710 | | TUDC12H4 | | |
| | | | | | | | 24 | 12-27.6 | 50 | | | TUDC48H4 | | |
| 0.55 | 19 | 59 | 0.24 | 32 | 4300 | 1.8 | 12 | 7.2-13.8 | 140 | 550 | TUDC12Z4F | TUDC12Z4 | | |
| | | | | | | | 24 | 12-27.6 | 80 | 270 | TUDC24Z4F | TUDC24Z4 | | |
| 0.47 | 17 | 39 | 0.16 | 27 | 3650 | 1.4 | 12 | 7.2-13.8 | 130 | 380 | TUDC12B4F | TUDC12B4 | | |
| | | | | | | | 24 | 12-27.6 | 70 | 190 | TUDC24B4F | TUDC24B4 | | |
| 0.35 | 12 | 24 | 0.10 | 20 | 2750 | 0.9 | 12 | 8.4-13.8 | 80 | 210 | TUDC12D4F | TUDC12D4 | | |
| | | | | | | | 24 | 14.4-27.6 | 40 | 110 | TUDC24D4F | TUDC24D4 | | |

● Figures in the table are average measured values. Please request the product delivery specification when preparing a purchase specification.

● The characteristics are the values at rated voltage (12 V, 24 V or 48 V), and normal temperature and humidity.

General specification

| | |
|--------------------|--|
| Materials Used | Venturi: ABS and PBT synthetic resins Propeller: ABS and PBT synthetic resins Bearing: Both side shielded ball bearing |
| Motor | Brushless DC motor, Protection type: Current shut off by detecting lock state, automatically reset |
| Common Elec. Spec. | See pages G-11, G-12, G-13. |
| Standard Carton | 100 to a carton of (450 x 380 x 160) mm, mass 9 kg |

● Venturi shape

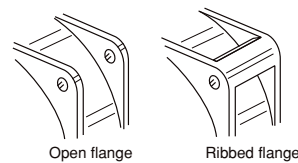

Specify no suffix symbol in your ordering information when the venturi is mounted with screws. Suffix 'F' for an open flange venturi.

Standard airflow and static pressure characteristics (At rated voltage)

[By double chamber method]

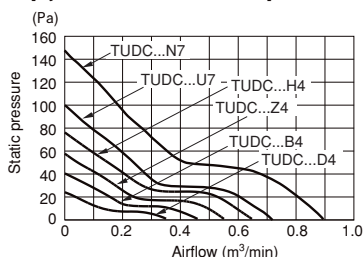

External dimensions in mm (inches)

● Lead wire type

Lead wire spec. AWG24 UL1007 or UL3266

Color (+) Red
(-) Black (TUDC□D4: Blue)

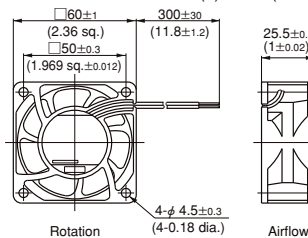

Wiring connection diagram

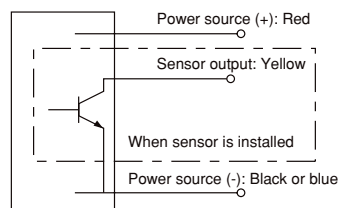

Mounting hole dimensions in mm (inches) [Recommendation]

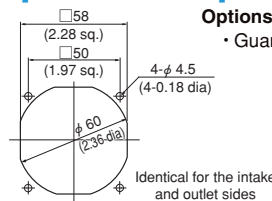

Options (sold separately)

- Guard: F60UL guard
- P60P guard

DC axial fan with sensor

| Rated Vol. | Model Code | | | | | |
|------------|------------|-----------|------------|------------|-----------|-----------|
| 12 V | TUDC12D4S | TUDC12B4S | TUDC12Z4S | TUDC12H4S | TUDC12U7S | TUDC12N7S |
| | TUDC12D4Q | | TUDC12Z4FS | TUDC12H4P | | |
| | | TUDC12B4P | TUDC12Z4P | TUDC12H4SQ | TUDC12U7P | TUDC12N7P |
| 24 V | TUDC24D4S | TUDC24B4S | TUDC24Z4S | TUDC24H4S | | TUDC24N7S |
| | | | TUDC24Z4SQ | | | |
| | | | TUDC24Z4FS | | | TUDC24N7P |
| 48 V | | TUDC48B4S | TUDC48Z4S | TUDC48H4P | | |
| | | TUDC48B4P | TUDC48Z4Q | TUDC48H4P | | |
| | | | TUDC48Z4P | | | |

● NIDEC SERVO can meet many of your requirements for customization, such as special connectors, other sensors not listed above, variable speed specifications, and other modifications. Please contact NIDEC SERVO during your product planning and development stage.

● The listed products are registered in the following overseas standards files, UL: E48889, CSA: LR49399, TUV: R9451586

● Customizing to the sleeve bearing specification also accepted depending on the intended purchase quantity. Contact NIDEC SERVO for further information.

● 3D data is also available at our web2-CAD site (www.cadenas.co.jp).

DC Axial Fan

PUDC



□ 80 × 25 (□ 3.2" × 1.0")
Max. airflow: 1.58 m³/min
Max. static pressure: 100 Pa
Mass: 85 g

Fan model code

- PUDC12B4
- PUDC12B4P
- PUDC12B4R
- PUDC12B4RS
- PUDC12B4S
- PUDC12D4
- PUDC12D4R
- PUDC12D4RS
- PUDC12D4S
- PUDC12H4
- PUDC12H4P
- PUDC12H4R
- PUDC12H4RS
- PUDC12H4S
- PUDC12U7
- PUDC12U7P
- PUDC12U7R
- PUDC12U7RP
- PUDC12U7RS
- PUDC12U7S
- PUDC12Z4
- PUDC12Z4P
- PUDC12Z4Q
- PUDC12Z4R
- PUDC12Z4RP
- PUDC12Z4RS
- PUDC12Z4S
- PUDC24B4
- PUDC24B4R
- PUDC24B4RQ
- PUDC24B4RS
- PUDC24B4S
- PUDC24D4
- PUDC24D4Q
- PUDC24D4R
- PUDC24D4RS
- PUDC24D4S
- PUDC24H4
- PUDC24H4R
- PUDC24H4RS
- PUDC24H4S
- PUDC24U7
- PUDC24U7R
- PUDC24U7RS
- PUDC24Z4
- PUDC24Z4P
- PUDC24Z4R
- PUDC24Z4RQ
- PUDC24Z4RS
- PUDC24Z4S
- PUDC48B4
- PUDC48B4P
- PUDC48B4R
- PUDC48B4S
- PUDC48Z4
- PUDC48Z4P
- PUDC48Z4S

Standard specification

| Max. Airflow | | Max. Static Pressure | | Noise dB | Speed min ⁻¹ | Input W | Voltage Spec. V | | Current mA | | Model Code | | Operating Temp. Range °C |
|---------------------|-----|----------------------|--------------------|----------|-------------------------|---------|-----------------|-----------------|------------|----------|-------------|---------------|--------------------------|
| m ³ /min | CFM | Pa | inH ₂ O | | | | Rating | Operating Range | Rating | Starting | Open Flange | Ribbed Flange | |
| 1.58 | 56 | 100 | 0.40 | 47 | 4560 | 4 | 12 | 7.2-13.8 | 340 | 1080 | PUDC12U7 | PUDC12U7R | -20 ~ +60 |
| | | | | | | 4.3 | 24 | 12-27.6 | 180 | 510 | PUDC24U7 | PUDC24U7R | |
| 1.32 | 47 | 74 | 0.30 | 40 | 3900 | 3.8 | 12 | 7.2-13.8 | 320 | 730 | PUDC12H4 | PUDC12H4R | |
| | | | | | | 2.4 | 24 | 12-27.6 | 160 | 340 | PUDC24H4 | PUDC24H4R | |
| 1.2 | 42 | 59 | 0.24 | 35 | 3500 | 3.2 | 48 | 24-55.2 | 70 | | PUDC48H4 | | |
| | | | | | | 2.4 | 12 | 7.2-13.8 | 160 | 520 | PUDC12Z4 | PUDC12Z4R | |
| 0.94 | 33 | 38 | 0.15 | 30 | 2800 | 2.6 | 48 | 24-55.2 | 60 | | PUDC48Z4 | | |
| | | | | | | 1.5 | 12 | 7.2-13.8 | 140 | 320 | PUDC12B4 | PUDC12B4R | |
| 0.73 | 26 | 25 | 0.10 | 23 | 2150 | 1.8 | 24 | 12-27.6 | 70 | 180 | PUDC24B4 | PUDC24B4R | -20 ~ +70 |
| | | | | | | 1 | 12 | 8.4-13.8 | 80 | 180 | PUDC12D4 | PUDC12D4R | |
| | | | | | | | 24 | 14.4-27.6 | 40 | | PUDC24D4 | PUDC24D4R | |

- Figures in the table are average measured values. Please request the product delivery specification when preparing a purchase specification.
- The characteristics are the values at rated voltage (12 V, 24 V or 48 V), and normal temperature and humidity.

General specification

| | |
|--------------------|--|
| Materials Used | Venturi: ABS and PBT synthetic resins Propeller: ABS and PBT synthetic resins Bearing: Both side shielded ball bearing |
| Motor | Brushless DC motor, Protection type: Current shut off by detecting lock state, automatically reset |
| Common Elec. Spec. | See pages G-11, G-12, G-13. |
| Standard Carton | 120 to a carton of (450 x 380 x 300) mm, mass 10 kg |

● Venturi shape

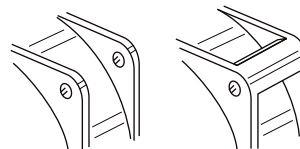

Use ribbed venturi with a reinforced corner when the venturi is mounted with screws. (The spacer is indicated in the model code by the letter 'R'.)

Standard airflow and static pressure characteristics (At rated voltage)

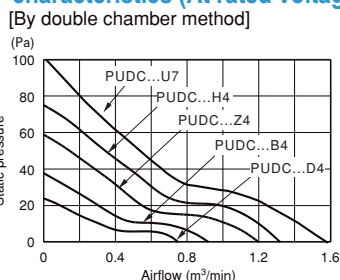

External dimensions in mm (inches)

- Lead wire type Lead wire spec. AWG24 UL1007 or UL3266
Color (+) Red (-) Black (PUDC□D4: Blue)

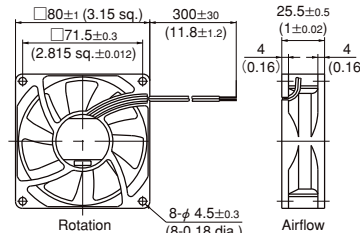

Wiring connection diagram

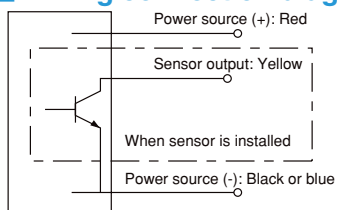

Mounting hole dimensions in mm (inches) [Recommendation]

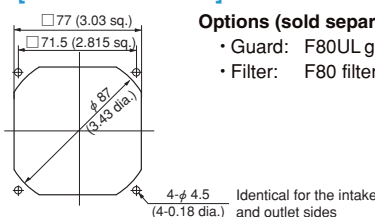

- Options (sold separately)
- Guard: F80UL guard
- Filter: F80 filter

DC axial fan with sensor

| Rated Vol. | Model Code | | | |
|------------|--------------------------------------|---------------------------------------|---|--------------------------------------|
| 12 V | PUDC12D4S PUDC12D4RS | PUDC12B4S PUDC12B4RS PUDC12B4P | PUDC12Z4S PUDC12Z4RS PUDC12Z4P PUDC12Z4RP PUDC12Z4Q | PUDC12H4S PUDC12H4RS PUDC12H4P |
| | PUDC24D4S PUDC24D4RS PUDC24D4Q | PUDC24B4S PUDC24B4RS PUDC24B4RQ | PUDC24Z4Q PUDC24Z4S PUDC24Z4RS PUDC24Z4P PUDC24Z4RQ | PUDC24H4S PUDC24H4RS |
| 24 V | | | | |
| 48 V | | PUDC48B4P | PUDC48Z4S PUDC48Z4P | PUDC48H4P |

- NIDEC SERVO can meet many of your requirements for customization, such as special connectors, other sensors not listed above, variable speed specifications, and other modifications. Please contact NIDEC SERVO during your product planning and development stage.
- The listed products are registered in the following overseas standards files, UL: E48889, CSA: LR49399, TUV: R9451586
- Customized fans with sleeve bearings are also available depending on the intended purchase quantity. Contact NIDEC SERVO for further information.
- 3D data is also available at our web2-CAD site (www.cadenas.co.jp).

GentleTyphoon™
D0925C



□ 90 × 25

Max. airflow: 2.0m³/min
Max. static pressure: 67Pa
Mass: 100 g

Fan model code

- D0925C12B4AS-00
- D0925C12B4AZ-00
- D0925C12B6AS-00
- D0925C12B6AZ-00
- D0925C12B8AS-00
- D0925C12B8AZ-00
- D0925C12B8ZP-00
- D0925C24B4AS-00
- D0925C24B4AZ-00
- D0925C24B6AS-00
- D0925C24B6AZ-00
- D0925C24B7AS-00
- D0925C24B7AZ-00
- D0925C24B8ZP-00

■ Features

- Wider low-noise operating range (50% increase)
- Significant vibration reduction using two methods.
- Energy efficiency (30% less input power than previous models)
- New design improves quality of sound.
- Sensor (lock, pulse) can be installed
- Variable speed (PWM, voltage, resistance) available

■ Standard specification

| Max. Airflow m³/min | Max. Static Pressure CFM | Max. Static Pressure | | Noise dB | Speed r/min | Voltage Spec. V | | Current mA | | Model Code | Operating Temp. Range °C |
|------------------------|-----------------------------|----------------------|--------------------|-------------|----------------|-----------------|-----------------|------------|----------|-----------------|--------------------------|
| | | Pa | inH ₂ O | | | Rating | Operating Range | Rating | Starting | | |
| 2.0 | 71 | 67 | 0.27 | 40* | 4450 | 12 | 10.2-13.2 | 330 | 850 | D0925C12B8AZ-00 | -20 ~ +60 |
| 1.84 | 65 | 55 | 0.22 | 38* | 4000 | 24 | 12.0-26.4 | 140 | 430 | D0925C24B7AZ-00 | -20 ~ +65 |
| 1.66 | 59 | 48 | 0.19 | 35* | 3750 | 12 | 10.2-13.2 | 200 | 650 | D0925C12B6AZ-00 | -20 ~ +70 |
| | | | | 36* | | 24 | 12.0-26.4 | 110 | 360 | D0925C24B6AZ-00 | |
| 1.5 | 53 | 40 | 0.16 | 32* | 3400 | 12 | 10.2-13.2 | 150 | 530 | D0925C12B4AZ-00 | |
| | | | | 34* | | 24 | 12.0-26.4 | 90 | 280 | D0925C24B4AZ-00 | |

* (as shown in the noise graph below).

- Figures in the table are average measured values. Please request the product delivery specification when preparing a purchase specification.
- The characteristics are the values at rated voltage (12 V or 24 V), and normal temperature and humidity.
- the only venturi shape available for these products is ribbed flange.
- This fan is specially designed for long life. At rated voltage and in continuous operation the expected life is 60,000 hours at 60°C, (100,000 hours at 40°C), (7.8 speed model: 55,000 hours at 60°C)

■ General specification

| | |
|--------------------|--|
| Materials Used | Venturi: SPS synthetic resins Propeller: SPS synthetic resins Bearing: Both side shielded ball bearing |
| Motor | Brushless DC motor, Protection type: Current shut off by detecting lock state, automatically reset |
| Common Elec. Spec. | See pages G-11, G-12, G-13. |
| Standard Carton | 70 to a carton of (450 x 380 x 300) mm, mass 7 kg |

■ Standard airflow and static pressure characteristics [At rated voltage]

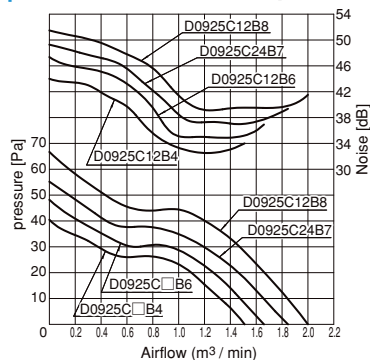

■ External dimensions in mm

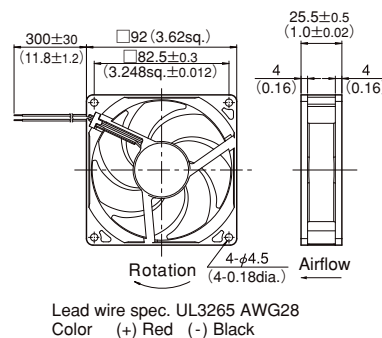

Lead wire spec. UL3265 AWG28
Color (+) Red (-) Black

■ Wiring connection diagram

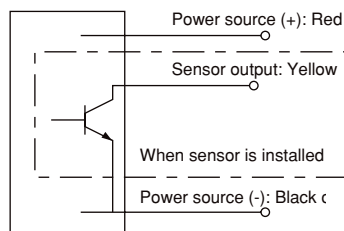

■ Mounting Hole Dimensions

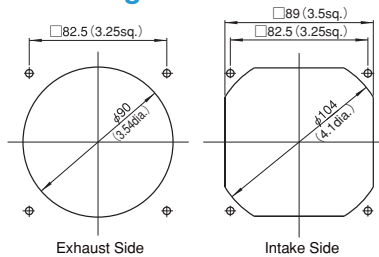

Options (sold separately)

- Guard: F92UL guard
- Filter: F92 filter

DC axial fan with sensor

| Rated Voltage | Model Code | | | |
|---------------|-----------------|-----------------|-----------------|------------------------------------|
| 12 V | D0925C12B4AS-00 | D0925C12B6AS-00 | | D0925C12B8AS-00 D0925C12B8ZP-00 |
| 24 V | D0925C24B4AS-00 | D0925C24B6AS-00 | D0925C24B7AS-00 | D0925C24B8ZP-00 |

- PWM (pulse width modulation) allowing for variable speed control is available in some models (reference the G-41 spec).
- NIDEC SERVO can meet many of your requirements for customization, such as special connectors, other sensors not listed above, variable speed specifications, and other modifications. Please contact NIDEC SERVO during your product planning and development stage.
- The listed products are registered in the following overseas standards files, UL/cUL:48889, TUV:R50004410:

DC Axial Fan
KLDC



□ 92 × 32 (□ 3.6" × 1.3")
Max. airflow: 2.1 m³/min
Max. static pressure: 140 Pa
Mass: 145 g

Fan model code

- KLDC12B4
- KLDC12B4F
- KLDC12B4S
- KLDC12U7
- KLDC12Z7
- KLDC12Z7FP
- KLDC12Z7FS
- KLDC12Z7P
- KLDC12Z7S
- KLDC24B4
- KLDC24B4F
- KLDC24B4S
- KLDC24H7
- KLDC24H7F
- KLDC24U7
- KLDC24Z7
- KLDC24Z7F
- KLDC24Z7S

Standard specification

| Max. Airflow | | Max. Static Pressure | | Noise dB | Speed min ⁻¹ | Input W | Voltage Spec. V | | Current mA | | Model Code | | Operating Temp. Range °C |
|---------------------|-----|----------------------|--------------------|-------------|----------------------------|------------|-----------------|-----------------|------------|------------------|------------------|-----------------|-----------------------------|
| m ³ /min | CFM | Pa | inH ₂ O | | | | Rating | Operating Range | Rating | Starting | Open Flange | Ribbed Flange | |
| 2.1 | 74 | 140 | 0.56 | 48 | 4600 | 5.7 | 12 | 6-13.8 | 470 | 1700 | | KLDC12U7 | -20 ~ +60 |
| | | | | | | 6.2 | 24 | 12-27.6 | 260 | 870 | | KLDC24U7 | |
| 1.9 | 67 | 115 | 0.46 | 45 | 4150 | 4.6 | 24 | 12-27.6 | 190 | 690 | KLDC24H7F | KLDC24H7 | -20 ~ +70 |
| 1.7 | 60 | 86 | 0.35 | 43 | 3800 | 4 | 12 | 7.2-13.8 | 340 | 960 | | KLDC12Z7 | |
| | | | | | | 3.6 | 24 | 12-27.6 | 150 | 480 | KLDC24Z7F | KLDC24Z7 | |
| 1.5 | 53 | 65 | 0.26 | 39 | 3200 | 12 | 12 | 7.2-13.8 | 280 | 570 | KLDC12B4F | KLDC12B4 | |
| | | | | | | 24 | 12-27.6 | 140 | | KLDC24B4F | KLDC24B4 | | |

- Figures in the table are average measured values. Please request the product delivery specification when preparing a purchase specification.
- The characteristics are the values at rated voltage (12 V or 24 V), and normal temperature and humidity.

General specification

| | |
|--------------------|--|
| Materials Used | Venturi: ABS and PBT synthetic resins Propeller: ABS and PBT synthetic resins Bearing: Both side shielded ball bearing |
| Motor | Brushless DC motor, Protection type: Current shut off by detecting lock state, automatically reset |
| Common Elec. Spec. | See pages G-11, G-12, G-13. |
| Standard Carton | 60 to a carton of (450 x 380 x 220) mm, mass 9 kg |

● Venturi shape

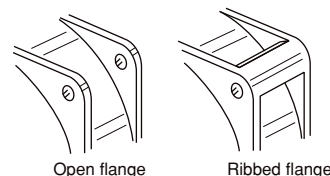

Specify no suffix symbol in your ordering information when the venturi is mounted with screws. Suffix 'F' for an open flange venturi.

Standard airflow and static pressure characteristics (At rated voltage)

[By double chamber method]

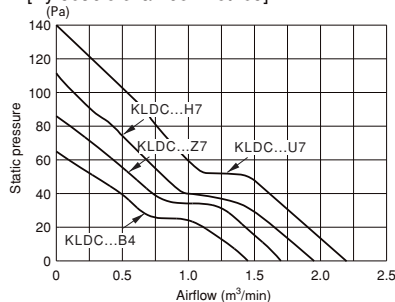

External dimensions in mm (inches)

- Lead wire type Lead wire spec. AWG24 UL1007 or UL3266
Color (+) Red
(-) Black

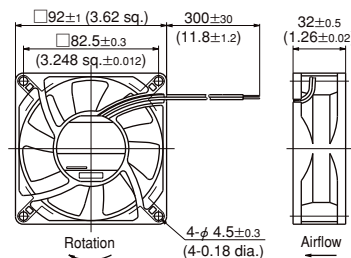

Wiring connection diagram

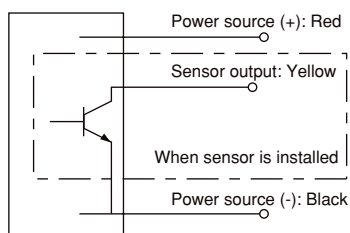

Mounting hole dimensions in mm (inches)
[Recommendation]

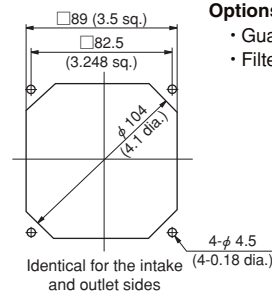

Options (sold separately)

- Guard: F92UL guard
- Filter: F92 filter

DC axial fan with sensor

| Rated Voltage | Model Code | |
|---------------|------------|------------|
| 12 V | KLDC12B4S | KLDC12Z7S |
| | | KLDC12Z7FS |
| | | KLDC12Z7P |
| | | KLDC12Z7FP |
| 24 V | KLDC24B4S | KLDC24Z7S |
| | | |

- NIDEC SERVO can meet many of your requirements for customization, such as special connectors, other sensors not listed above, variable speed specifications, and other modifications. Please contact NIDEC SERVO during your product planning and development stage.
- The listed products are registered in the following overseas standards files, UL: E48889, CSA: LR49399, TUV: R9451586
- 3D data is also available at our web2-CAD site (www.cadenas.co.jp).

Brushless
DC Fans & Blowers

GentleTyphoon™
D1225C (for low speed applications) **Series** □ 120 × 25 mm

GentleTyphoon™
D1225C



□ 120 × 25 (□ 4.7" × 1.0")

Max. airflow: 1.65 m³/min
Max. static pressure: 20 Pa
Mass: 200g

Fan model code

D1225C12B4AZ-00

D1225C12B5AZ-00

D1225C12B6AP-00

D1225C12B6AS-00

D1225C12B6AZ-00

D1225C24B4AZ-00

D1225C24B5AZ-00

Features

- Wide low-noise range (noise reduced in high density devices)
- 2-way vibration reduction (lowers resonant noise of entire device)
- Energy Efficient (wide reduction compared to previous model)
- Design to improve sound (for low speed applications)
- Sensors Available (lock, pulse)
- Variable speed available (PWM, voltage resistance)

Standard specification

| Max. Airflow | | Max. Static Pressure | | Noise | Speed | Voltage Spec. V | | Current mA | | Model Code | Operating Temp. Range C |
|---------------------|-----|----------------------|--------------------|-------|-------|-----------------|-----------------|------------|----------|-----------------|-------------------------|
| m ³ /min | CFM | Pa | inH ₂ O | dB | r/min | Rating | Operating Range | Rating | Starting | | |
| 1.95 | 69 | 28 | 0.113 | 30* | 2150 | 12 | 5.0-13.2 | 123 | 530 | D1225C12B6AZ-00 | -10 ~ +60 |
| 1.65 | 58 | 20 | 0.081 | 26* | 1850 | 12 | 5.0-13.2 | 83 | 360 | D1225C12B5AZ-00 | |
| | | | | | | 24 | 12.0-26.4 | 45 | 190 | D1225C24B5AZ-00 | |
| 1.30 | 46 | 13 | 0.051 | 19* | 1450 | 12 | 7.0-13.2 | 49 | 210 | D1225C12B4AZ-00 | |
| | | | | | | 24 | 12.0-26.4 | 29 | 100 | D1225C24B4AZ-00 | |

*Noise values shown (at 1m) were converted as follows subtract 12dB from actual noise measurements taken at 25cm (as shown in the noise graph below).

- Figures in the table are average measured values. Please request the product delivery specification when preparing a purchase specification.
- The characteristics are the values at rated voltage (12 V or 24 V), and normal temperature and humidity.
- The only venturi shape available for these products is ribbed flange.
- Depending on quantities, Nidec Servo can meet many of your requirements for customization, such as special connectors, sensors, variable speed specifications and other modifications. Please contact Nidec Servo for more information.
- This fan is specially designed for long life. At rated voltage and in continuous operation the expected life is 60,000 hours at 60°C, (100,000 hours at 35°C), (5.6 speed model; 55,000 hours at 60°C).

General specification

| | |
|--------------------|--|
| Materials Used | Venturi: PBT-ABS synthetic resins Propeller: PBT-ABS synthetic resins Bearing: Both side shielded ball bearing |
| Motor | Brushless DC motor, Protection type: Current shut off by detecting lock state, automatically reset |
| Common Elec. Spec. | See pages G-11, G-12, G-13. |
| Standard Carton | 60 to a carton of (450 x 380 x 300) mm, mass 13 kg |

- 8 pockets (2 each provided in 4 places on flanged ribs) hold the M4 nuts (not included), and make for easy attachment.

Standard airflow and static pressure characteristics (At rated voltage)

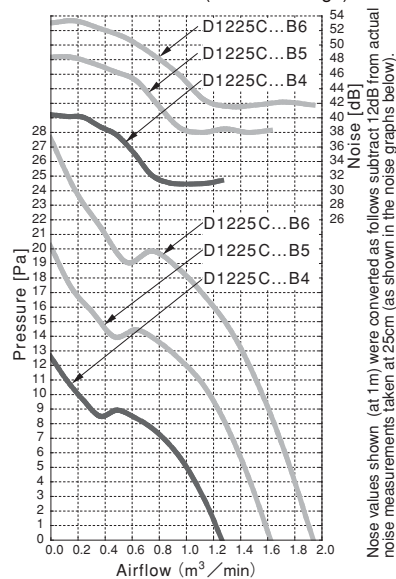

External dimensions in mm (inches)

● Lead wire type

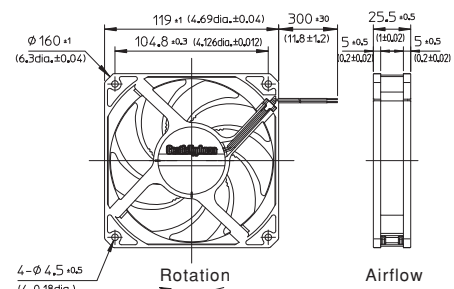

Mounting hole dimensions in mm (inches)
[Recommendation]

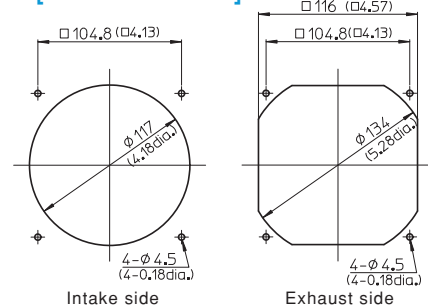

Options (sold separately)

- Guard: F120UL guard
- Filter: F120 filter

Wiring connection diagram

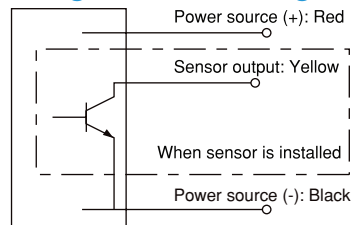

DC axial fan with sensor

| Rated Voltage | Model Code |
|---------------|-----------------|
| 12 V | D1225C12B6AP-00 |
| | D1225C12B6AS-00 |

- NIDEC SERVO can meet many of your requirements for customization, such as special connectors, other sensors not listed above, variable speed specifications, and other modifications. Please contact NIDEC SERVO during your product planning and development stage.
- The listed products are registered in the following overseas standards files, UL/cUL: E48889, TUV: R50004410

Brushless DC Fans & Blowers

GentleTyphoon™ D1225C



□ 120×25mm(□4.7"×1.0")
 Max. airflow : 4.25m³/min
 Max. static pressure : 150Pa
 Mass : 200g

Fan model code

- D1225C12B7AZ-00
- D1225C12B9AZ-00
- D1225C12BBAZ-00
- D1225C12BBZP-00
- D1225C24B7AZ-00
- D1225C24B9AZ-00
- D1225C24BBAZ-00
- D1225C24BBZP-00

Features

- Surge-less PQ performance (increased airflow)
- Direct rearward, high impetus airflow (improved cooling)
- 2-way vibration reduction (lowers resonant noise of entire device)
- Design to improve sound (improved noise)
- Sensors Available (lock, pulse)
- Variable speed available (PWM)

GentleTyphoon™

D1225C (for high speed applications) Series □ 120×25mm

Standard specification

| Max. Airflow m ³ /min CFM | Max. Static Pressure Pa inH ₂ O | Noise dB | Speed r/min | Voltage Spec. V | | Current mA | | Model Code | Operating Temp. Range C | Expectation Life | | |
|--|--|-------------|----------------|-----------------|-----------------|------------|------------|------------|-------------------------|------------------|---------|-------------------------------|
| | | | | Rating | Operating Range | Rating | Starting | | | | | |
| 4.25 | 150.1 | 150 | 0.60 | 50.5* | 5400 | 12 | 10.2 -13.8 | 1140 | 2690 | D1225C12BBAZ-00 | -20~+60 | 60°C 45000hr 35°C 100000hr |
| | | | | | | 24 | 20.4 -27.6 | 580 | 1210 | D1225C24BBAZ-00 | | |
| 3.30 | 116.5 | 95 | 0.38 | 44* | 4250 | 12 | 10.2 -13.8 | 560 | 1350 | D1225C12B9AZ-00 | | 60°C 60000hr 35°C 100000hr |
| | | | | | | 24 | 20.4 -27.6 | 290 | 650 | D1225C24B9AZ-00 | | |
| 2.35 | 83.0 | 49 | 0.20 | 36.5* | 3000 | 12 | 10.2 -13.8 | 220 | 970 | D1225C12B7AZ-00 | | |
| | | | | | | 24 | 20.4 -27.6 | 140 | 530 | D1225C24B7AZ-00 | | |

* Noise values shown at quiet zone (as shown in the noise graph below).

- Figures in the table are average measured values. Please request the product delivery specification when preparing a purchase specification.
- The characteristics are the values at rated voltage, and normal temperature and humidity.
- The only venturi shape available for these products is a ribbed flange.
- Depending on quantities, Nidec Servo can meet many of your requirements for customization, such as special connectors, sensors, variable speed specifications and other modifications. Please contact Nidec Servo for more information.
- This fan is specially designed for long life. Above indicated longevity is based on continuous operation at: 90% survivability, standard voltage and free air.

General specification

| | |
|----------------|---|
| Materials Used | Venturi : PBT-ABS synthetic resins Propeller : PBT-ABS synthetic resins Bearing : Both side shielded ball bearing |
| Motor | Brushless DC motor, Protection type : Current shut off by detecting lock state, automatically reset |

- Each of the eight flanged ribs has "nut insert" receptacles for the M4 nuts (not included) which allow for easy attachment.

Standard airflow and static pressure characteristics

(At rated voltage)

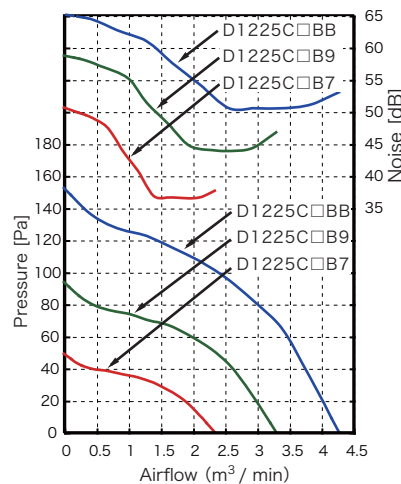

External dimensions in mm (inches)

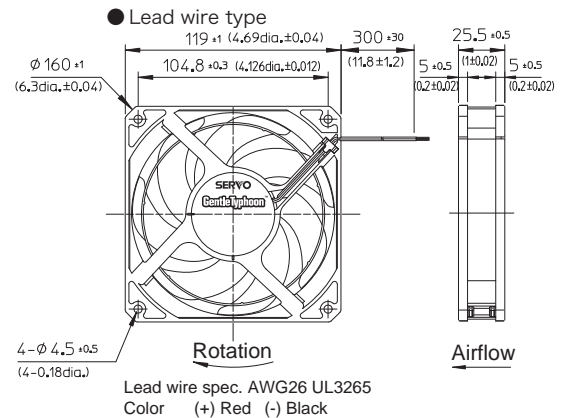

Mounting Hole dimensions in mm (inches) [Recommendation]

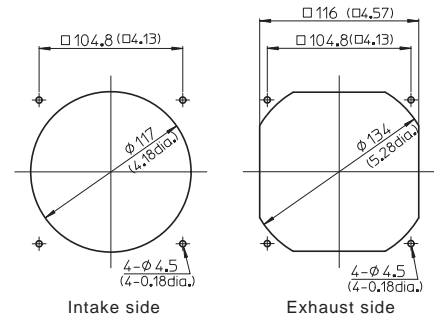

Wiring connection diagram

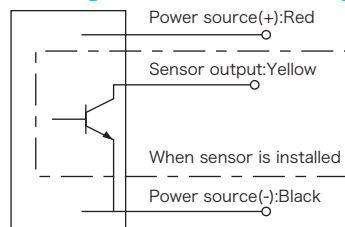

DC axial fan with sensor

| Rated Voltage | Model Code |
|---------------|-----------------|
| 12 V | D1225C12BBZP-00 |
| 24 V | D1225C24BBZP-00 |

Options (sold separately)

- Guard: F120UL guard
- Filter: F120 filter

- NIDEC SERVO can meet many of your requirements for customization, such as special connectors, other sensors not listed above, variable speed specifications, and other modifications. Please contact NIDEC SERVO during your product planning and development stage.
- The listed products are registered in the following overseas standards files, UL/cUL: E48889, TUV: R5004410

DC Axial Fan

CNDC



□ 120 × 38 (□ 4.7" × 1.5")
Max. airflow: 4.4 m³/min
Max. static pressure: 160 Pa
Mass: 250 g

Fan model code

- CNDC12B7
- CNDC12B7P
- CNDC12B7S
- CNDC12D7
- CNDC12D7P
- CNDC12D7V
- CNDC12H7
- CNDC12U7
- CNDC12Z7
- CNDC12Z7P
- CNDC12Z7Q
- CNDC12Z7S
- CNDC24B7
- CNDC24B7P
- CNDC24B7Q
- CNDC24B7S
- CNDC24B7SQ
- CNDC24B7V
- CNDC24B7VS
- CNDC24D7
- CNDC24D7Q
- CNDC24D7S
- CNDC24H7
- CNDC24U7
- CNDC24Z7
- CNDC24Z7P
- CNDC24Z7Q
- CNDC24Z7S
- CNDC24Z7V
- CNDC48B7
- CNDC48B7P
- CNDC48B7S
- CNDC48Z7
- CNDC48Z7P
- CNDC48Z7S
- CNDC48Z7V

Standard specification

| Max. Airflow m ³ /min | CFM | Max. Static Pressure Pa | inH ₂ O | Noise dB | Speed min ⁻¹ | Input W | Voltage Spec. V | | Current mA | | Model Code | | Operating Temp. Range °C |
|-------------------------------------|-----|----------------------------|--------------------|-------------|----------------------------|------------|-----------------|-----------------|------------|----------|-------------|-------------|-----------------------------|
| | | | | | | | Rating | Operating Range | Rating | Starting | Open Flange | With Spacer | |
| 4.4 | 155 | 160 | 0.64 | 52 | 3800 | 11.2 | 12 | 8.4-13.8 | 930 | 2100 | CNDC12U7 | | -20 ~ +70 |
| | | | | | | 10.8 | 24 | 19.2-27.6 | 450 | 2000 | CNDC24U7 | | |
| 4.0 | 141 | 140 | 0.56 | 51 | 3550 | 9.1 | 12 | 8.4-13.8 | 760 | 2080 | CNDC12H7 | | |
| | | | | | | 9.4 | 24 | 19.2-27.6 | 390 | 1970 | CNDC24H7 | | |
| 3.5 | 124 | 105 | 0.42 | 49 | 3200 | 8.6 | 12 | 7.2-13.8 | 710 | 2350 | CNDC12Z7 | | |
| | | | | | | 9.0 | 24 | 12-27.6 | 370 | 1200 | CNDC24Z7 | CNDC24Z7V | |
| | | | | | | 10.0 | 48 | 24-55.2 | 210 | 530 | CNDC48Z7 | CNDC48Z7V | |
| | | | | | | 4.6 | 12 | 7.2-13.8 | 380 | 1330 | CNDC12B7 | | |
| 2.8 | 99 | 70 | 0.28 | 40 | 2650 | 4.8 | 24 | 12-27.6 | 200 | 640 | CNDC24B7 | CNDC24B7V | |
| | | | | | | 6 | 48 | 24-55.2 | 120 | 340 | CNDC48B7 | | |
| 2.1 | 74 | 44 | 0.18 | 32 | 1950 | 2.4 | 12 | 8.4-13.8 | 200 | | CNDC12D7 | CNDC12D7V | |
| | | | | | | 2.6 | 24 | 14.4-27.6 | 110 | | CNDC24D7 | | |

- Figures in the table are average measured values. Please request the product delivery specification when preparing a purchase specification.
- The characteristics are the values at rated voltage (12 V, 24 V or 48 V), and normal temperature and humidity.
- The life expectancy of CNDC-Z speed products at rated voltage and in continuous operation is 30,000 hours at 60°C. (40,000 hours for other products)

General specification

| | |
|--------------------|--|
| With Spacer | Venturi: ABS and PBT synthetic resins Propeller: ABS and PBT synthetic resins Bearing: Both side shielded ball bearing |
| Motor | Brushless DC motor, Protection type: Current shut off by detecting lock state, automatically reset |
| Common Elec. Spec. | See pages G-11, G-12, G-13. |
| Standard Carton | 40 to a carton of (450 x 380 x 300) mm, mass 12 kg |

● Venturi shape

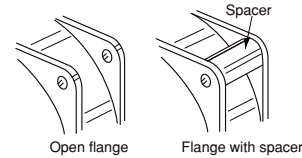

Use the reinforced product with spacer when the venturi is mounted with screws. (The spacer is indicated in the model code by the letter 'V'.)

Standard airflow and static pressure characteristics (At rated voltage)

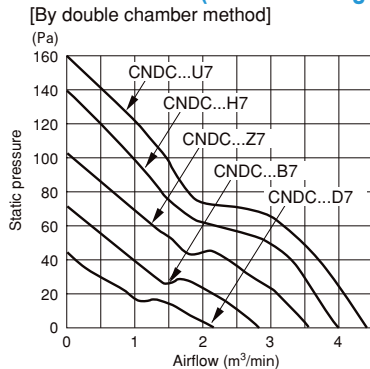

External dimensions in mm (inches)

- Lead wire type Lead wire spec. AWG24 UL1007 or UL3266
Color (+) Red
(-) Black (CNDC□D7: Blue)

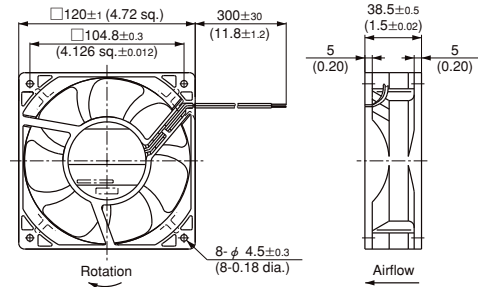

Wiring connection diagram

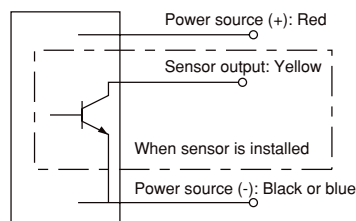

Mounting hole dimensions in mm (inches)
[Recommendation]

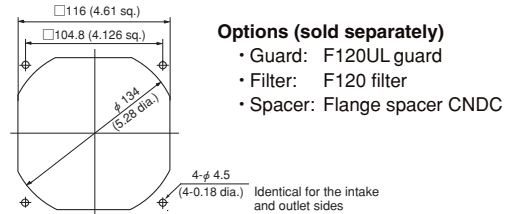

Options (sold separately)

- Guard: F120UL guard
- Filter: F120 filter
- Spacer: Flange spacer CNDC

DC axial fan with sensor

| Rated Vol. | Model Code | | |
|------------|------------------------|---|-------------------------------------|
| 12 V | CNDC12D7P | CNDC12B7S CNDC12B7P | CNDC12Z7S CNDC12Z7Q |
| | CNDC24D7S CNDC24D7Q | CNDC24B7S CNDC24B7VS CNDC24B7P CNDC24B7Q CNDC24B7SQ | CNDC24Z7S CNDC24Z7P CNDC24Z7Q |
| 24 V | CNDC48B7S CNDC48B7P | CNDC48Z7S CNDC48Z7P | |

- NIDEC SERVO can meet many of your requirements for customization, such as special connectors, other sensors not listed above, variable speed specifications, and other modifications. Please contact NIDEC SERVO during your product planning and development stage.
- The listed products are registered in the following overseas standards files, UL/cUL: E48889 (Except H, U speed models), CSA: LR49399 (H, U speed model only), TUV: R9451586
- 3D data is also available at our web2-CAD site (www.cadenas.co.jp).

DC Axial Fan
D1238B



□120×38 (□4.7"×1.5")
Max. airflow: 6.2 m³/min
Max. static pressure: 300 Pa
Mass: 430 g

Fan model code

- D1238B12B7AZ-00
- D1238B12B8AP-00
- D1238B12B8AZ-00
- D1238B12B9AP-00
- D1238B12B9AZ-00
- D1238B24B7AP-00
- D1238B24B7AZ-00
- D1238B24B8AS-00
- D1238B24B8AZ-00
- D1238B24B9AP-00
- D1238B24B9AS-00
- D1238B24B9AZ-00
- D1238B24BAAZ-00
- D1238B48B7AP-00
- D1238B48B7AZ-00
- D1238B48B8AP-00
- D1238B48B8AS-00
- D1238B48B8AZ-00
- D1238B48B9AP-00
- D1238B48B9AS-00
- D1238B48B9AZ-00
- D1238B48BAAP-00
- D1238B48BAAS-00
- D1238B48BAAZ-00

Standard specification

| Max. Airflow | | Max. Static Pressure | | Noise dB | Speed min ⁻¹ | Input W | | Voltage Spec. V | | Current mA | | Model Code | Operating Temp. Range °C |
|---------------------|-----|----------------------|--------------------|-------------|----------------------------|------------|-----------------|-----------------|----------|------------|-----------------|------------|-----------------------------|
| m ³ /min | CFM | Pa | inH ₂ O | | | Rating | Operating Range | Rating | Starting | Rating | Starting | | |
| 6.2 | 219 | 300 | 1.21 | 62 | 5500 | 26.4 | 24 | 18-27.6 | 1100 | 2700 | D1238B24BAAZ-00 | -20 ~ +70 | |
| | | | | | | 26.4 | 48 | 36-55.2 | 560 | | D1238B48BAAZ-00 | | |
| 5.25 | 185 | 250 | 1.01 | 59 | 4900 | 19.8 | 12 | 8.4-13.8 | 1650 | 5200 | D1238B12B9AZ-00 | | |
| | | | | | | 19.7 | 24 | 16.8-27.6 | 820 | 2600 | D1238B24B9AZ-00 | | |
| | | | | | | 19.2 | 48 | 36-55.2 | 400 | 950 | D1238B48B9AZ-00 | | |
| | | | | | | 14.4 | 12 | 8.4-13.8 | 1200 | | D1238B12B8AZ-00 | | |
| 4.8 | 169 | 185 | 0.74 | 56 | 4400 | 13.9 | 24 | 16.8-27.6 | 580 | 1850 | D1238B24B8AZ-00 | | |
| | | | | | | 15.4 | 48 | 36-55.2 | 320 | | D1238B48B8AZ-00 | | |
| 4.4 | 155 | 160 | 0.64 | 54 | 4000 | 14.4 | 12 | 8.4-13.8 | 1200 | | D1238B12B7AZ-00 | | |
| | | | | | | 14.4 | 24 | 16.8-27.6 | 600 | 1600 | D1238B24B7AZ-00 | | |
| | | | | | | 12.0 | 48 | 36-55.2 | 250 | 1600 | D1238B48B7AZ-00 | | |

- Figures in the table are average measured values. Please request the product delivery specification when preparing a purchase specification.
- The characteristics are the values at rated voltage (12 V, 24 V or 48 V), and normal temperature and humidity.

General specification

| | |
|--------------------|---|
| Materials Used | Venturi: Aluminum alloy die castings Propeller: ABS and PBT synthetic resins Bearing: Both side shielded ball bearing |
| Motor | Brushless DC motor, Protection type: Overcurrent detection and automatic resetting by current limiting |
| Common Elec. Spec. | See pages G-11, G-12, G-13. |

Standard airflow and static pressure characteristics (At rated voltage)

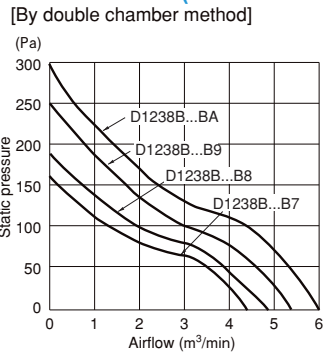

Wiring connection diagram

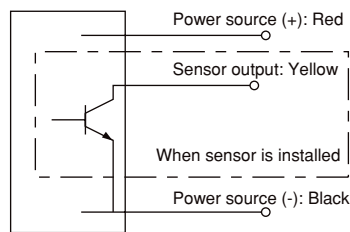

External dimensions in mm (inches)

Lead wire type

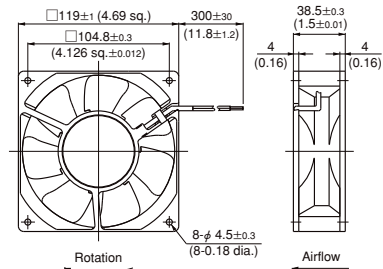

Lead wire spec. AWG24 UL1007 or UL3266
Color (+) Red
(-) Black

Mounting hole dimensions in mm (inches)
[Recommendation]

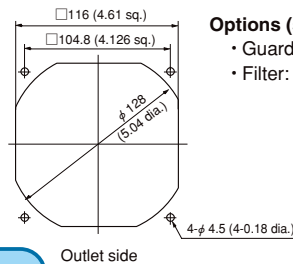

Options (sold separately)

- Guard: F120UL guard
- Filter: F120 filter

Customized fans with a higher airflow are also available.
Please contact NIDEC SERVO for more information.

DC axial fan with sensor

| Rated Vol. | Model Code | | | |
|------------|-----------------|-----------------|-----------------|-----------------|
| 12 V | | D1238B12B8AP-00 | D1238B12B9AP-00 | |
| 24 V | D1238B24B7AP-00 | D1238B24B8AS-00 | D1238B24B9AS-00 | D1238B24B9AP-00 |
| 48 V | D1238B48B7AP-00 | D1238B48B8AS-00 | D1238B48B9AS-00 | D1238B48BAAS-00 |
| | | D1238B48B8AP-00 | D1238B48B9AP-00 | D1238B48BAAP-00 |

- NIDEC SERVO can meet many of your requirements for customization, such as special connectors, other sensors not listed above, variable speed specifications, and other modifications. Please contact NIDEC SERVO during your product planning and development stage.
- The listed products are registered in the following overseas standards files, UL: E129458, CSA: LR49399, TUV: R50004410
- 3D data is also available at our web2-CAD site (www.cadenas.co.jp).

DC Axial Fan
D1338B



□ 127 × 38 (□ 5.0" × 1.5")

Max. airflow: 5.8 m³/min
Max. static pressure: 185 Pa
Mass: 410 g

Standard specification

| Max. Airflow m ³ /min | Max. Static Pressure CFM Pa | Noise dB | Speed min ⁻¹ | Input W | Voltage Spec. V | | Current mA | | Model Code | Operating Temp. Range °C | | |
|-------------------------------------|--------------------------------|-------------|----------------------------|------------|-----------------|-----------------|------------|-----------|------------|-----------------------------|-----------|------------------------|
| | | | | | Rating | Operating Range | Rating | Starting | | | | |
| 5.8 | 205 | 185 | 0.74 | 58 | 4500 | 19.8 | 12 | 8.4-13.8 | 1650 | D1338B12B8AZ-00 | -20 ~ +70 | |
| | | | | | | 19.7 | 24 | 16.8-27.6 | 820 | 2500 | | D1338B24B8AZ-00 |
| | | | | | | 21.1 | 48 | 36-55.2 | 440 | 940 | | D1338B48B8AZ-00 |
| 5 | 177 | 150 | 0.60 | 54 | 3900 | 16.2 | 12 | 8.4-13.8 | 1350 | D1338B12B7AZ-00 | | |
| | | | | | | 15.6 | 24 | 16.8-27.6 | 650 | | | D1338B24B7AZ-00 |
| | | | | | | 16.8 | 48 | 36-55.2 | 350 | | | D1338B48B7AZ-00 |
| 4.6 | 162 | 130 | 0.52 | 51 | 3400 | 12.0 | 12 | 8.4-13.8 | 1000 | D1338B12B6AZ-00 | | |
| | | | | | | | 24 | 16.8-27.6 | 500 | 1600 | | D1338B24B6AZ-00 |
| | | | | | | | 48 | 36-55.2 | 250 | 1150 | | D1338B48B6AZ-00 |

● Figures in the table are average measured values. Please request the product delivery specification when preparing a purchase specification.
● The characteristics are the values at rated voltage (12 V, 24 V or 48 V), and normal temperature and humidity.

General specification

| | |
|--------------------|---|
| Materials Used | Venturi: Aluminum alloy die castings Propeller: ABS and PBT synthetic resins Bearing: Both side shielded ball bearing |
| Motor | Brushless DC motor, Protection type: Overcurrent detection and automatic resetting by current limiting |
| Common Elec. Spec. | See pages G-11, G-12, G-13. |

Standard airflow and static pressure characteristics (At rated voltage)

[By double chamber method]

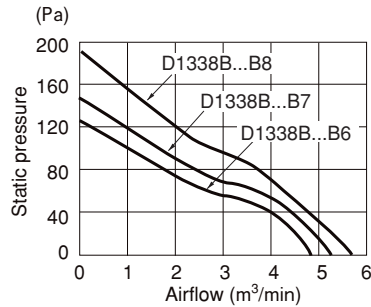

External dimensions in mm (inches)

● Lead wire type

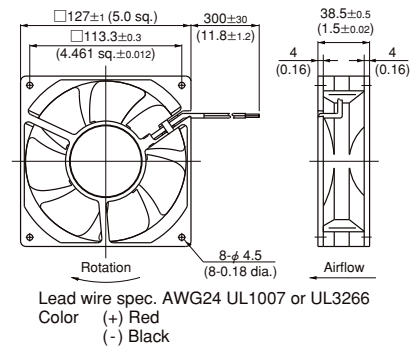

Wiring connection diagram

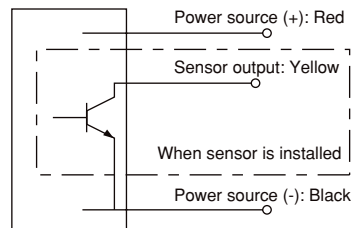

Mounting hole dimensions in mm (inches)
[Recommendation]

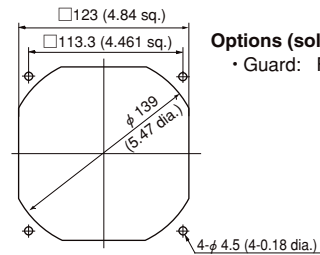

Options (sold separately)
• Guard: F127UL guard

DC axial fan with sensor

| Rated Vol. | Model Code | | |
|------------|------------------------|------------------------|------------------------|
| 24 V | D1338B24B7AS-00 | D1338B24B8AS-00 | D1338B24B8AP-00 |
| | D1338B48B7AS-00 | D1338B48B8AS-00 | D1338B48B8AP-00 |
| 48 V | D1338B48B6AP-00 | D1338B48B7AP-00 | D1338B48B8AP-00 |

● NIDEC SERVO can meet many of your requirements for customization, such as special connectors, other sensors not listed above, variable speed specifications, and other modifications. Please contact NIDEC SERVO during your product planning and development stage.
● The listed products are registered in the following overseas standards files, UL: E48889, CSA: LR49399, TUV: 50004410
● 3D data is also available at our web2-CAD site (www.cadenas.co.jp).

DC Axial Fan
D1751M



$\phi 172 \times 150 \times 51$
($\phi 6.8" \times 6.0" \times 2.0"$)
Max. airflow : 14.2 m³/min
Max. static pressure : 580 Pa
Mass : 780 g

Fan model code

- D1751M12B1AS-00
- D1751M12B1AZ-00
- D1751M12B2AP-00
- D1751M12B2AS-00
- D1751M12B2AZ-00
- D1751M12B3AP-00
- D1751M12B3AS-00
- D1751M12B3AZ-00
- D1751M12B4AP-00
- D1751M12B4AS-00
- D1751M12B4AZ-00
- D1751M24B1AP-00
- D1751M24B2AP-00
- D1751M24B2AS-00
- D1751M24B2AZ-00
- D1751M24B3AP-00
- D1751M24B3AS-00
- D1751M24B3AZ-00
- D1751M24B4AP-00
- D1751M24B4AS-00
- D1751M24B4AZ-00
- D1751M24B7AP-00
- D1751M24B7AZ-00
- D1751M24B7ZP-00
- D1751M24B8ZP300
- D1751M24B9ZP300
- D1751M48B2AP-00
- D1751M48B2AS-00
- D1751M48B2AZ-00
- D1751M48B3AP-00
- D1751M48B3AS-00
- D1751M48B3AZ-00
- D1751M48B4AP-00
- D1751M48B4ZP-00
- D1751M48B6AP-00
- D1751M48B6ZP-00
- D1751M48B7ZP-00
- D1751M48B8ZP-00
- D1751M48B9ZP-00

Standard specification

| Max. airflow m ³ /min | Max. static pressure Pa | Noise inHzO | Speed min ⁻¹ | Voltage spec. V | | Current mA | | Model code | Operating temp. range C | | | |
|-------------------------------------|----------------------------|----------------|----------------------------|-----------------|-----------------|------------|-----------|------------|----------------------------|-----------------|-----------------|-----------------|
| | | | | Rating | Operating Range | Rating | Starting | | | | | |
| 14.2 | 501 | 580 | 2.33 | 75 | 6800 | 24 | 16-28 | 4600 | 6900 | D1751M24B9ZP300 | -20 ~ +60 | |
| | | | | | | 48 | 36-60 | 2300 | 6000 | | | D1751M48B9ZP-00 |
| 12.7 | 448 | 510 | 2.05 | 72 | 6100 | 24 | 16-28 | 3400 | 4800 | D1751M24B8ZP300 | | |
| | | | | | | 48 | 36-60 | 1650 | 3500 | | | D1751M48B8ZP-00 |
| 11.4 | 402 | 410 | 1.65 | 69 | 5400 | 24 | 12-27.6 | 2450 | 5600 | D1751M24B7AP-00 | | |
| | | | | | | 48 | 36-60 | 1200 | 2350 | | | D1751M48B7ZP-00 |
| 10.2 | 360 | 315 | 1.27 | 64 | 4800 | 24 | 12-27.6 | 1800 | 3200 | D1751M24B6ZP-00 | | |
| | | | | | | 48 | 36-60 | 820 | 1800 | | | D1751M48B6ZP-00 |
| 9 | 318 | 260 | 1.04 | 61 | 4200 | 24 | 12-27.6 | 1200 | 2200 | D1751M24B5AP-00 | | |
| | | | | | | 48 | 36-60 | 600 | 1150 | | | D1751M48B5ZP-00 |
| 8 | 282 | 205 | 0.82 | 57 | 3800 | 12 | 8.4-13.8 | 1840 | 3800 | D1751M12B4AZ-00 | -20 ~ +70 | |
| | | | | | | 24 | 12-27.6 | 900 | 2200 | | | D1751M24B4ZP-00 |
| | | | | | | 48 | 36-60 | 450 | 860 | | | D1751M48B4ZP-00 |
| 6.8 | 240 | 155 | 0.62 | 54 | 3200 | 12 | 8.4-13.8 | 1200 | 3400 | D1751M12B3AZ-00 | | |
| | | | | | | 24 | 12-27.6 | 600 | 2400 | | | D1751M24B3AZ-00 |
| 5.8 | 205 | 120 | 0.48 | 49 | 2800 | 48 | 28.8-55.2 | 310 | 900 | D1751M48B3AZ-00 | | |
| | | | | | | 12 | 8.4-13.8 | 800 | 2900 | | | D1751M12B2AZ-00 |
| | | | | | | 24 | 12-27.6 | 400 | 1900 | | | D1751M24B2AZ-00 |
| 4.2 | 148 | 67 | 0.27 | 41 | 2000 | 48 | 28.8-55.2 | 210 | 700 | D1751M48B2AZ-00 | | |
| | | | | | | 12 | 8.4-13.8 | 390 | 2200 | | | D1751M12B1AZ-00 |
| | | | | | | 24 | 12-27.6 | 200 | 1150 | | D1751M24B1AP-00 | |

● Figures in the table are average measured values. Please request the product delivery specification when preparing a purchase specification.
● The characteristics are the values at rated voltage (12 V, 24 V, 48 V), and normal temperature and humidity.

General specification

| | |
|--------------------|--|
| Materials Used | Venturi: Aluminum alloy die castings Propelle: ABS and PBT synthetic resins Bearing: Both side shielded ball bearing |
| Motor | Brushless DC motor, Protection type: Overcurrent detection and automatic resetting by current limiting |
| Common Elec. Spec. | See pages G-11, G-12, G-13. |
| Standard Carton | 12 to a carton of (450 x 380 x 220)mm, mass 10kg |

Mouting hole dimensions in mm (inches)[Recommendation]

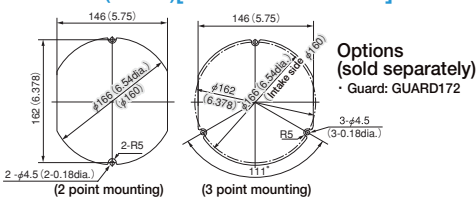

Standard airflow and static pressure characteristics (At rated voltage)

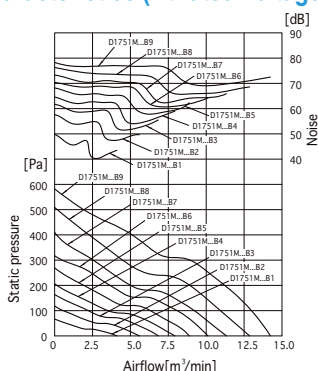

External dimensions in mm (inches)

● Lead wire type

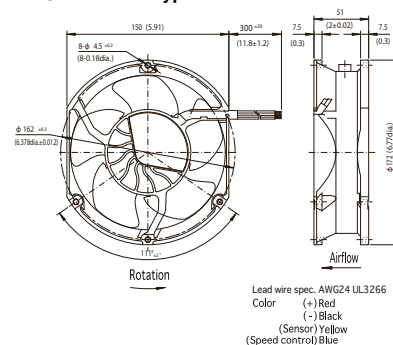

PWM speed control specification

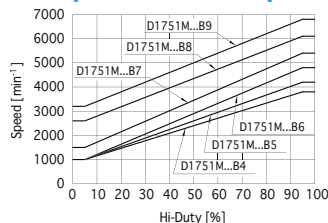

Speed performance (At rated vol., Air specification (Room temperature))

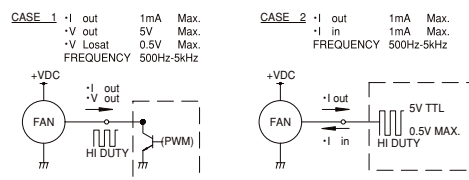

DC axial fan with sensor

| Rated Vol. | Model Code | | | | | | | |
|------------|-----------------|-----------------|-----------------|-----------------|-----------------|-----------------|-----------------|-----------------|
| 12 V | D1751M12B1AS-00 | D1751M12B2AP-00 | D1751M12B3AP-00 | D1751M12B4AP-00 | D1751M12B2AS-00 | D1751M12B3AS-00 | D1751M12B4AS-00 | |
| 24V | D1751M24B1AP-00 | D1751M24B2AP-00 | D1751M24B3AP-00 | D1751M24B4AP-00 | D1751M24B2AZ-00 | D1751M24B3AZ-00 | D1751M24B4AZ-00 | D1751M24B9ZP300 |
| 48V | | D1751M48B2AP-00 | D1751M48B3AP-00 | D1751M48B4AP-00 | D1751M48B2AZ-00 | D1751M48B3AZ-00 | D1751M48B4AZ-00 | D1751M48B9ZP-00 |

● NIDECE SERVO can meet many of your requirements for customization, such as special connectors, other sensors not listed above, variable speed specifications, and other modifications. Please contact NIDECE SERVO during your product planning and development stage.
● PWM (pulse width modulation) allowing for variable speed control is available in some models (reference the G-41 spec.)
● The listed products are registered in the following overseas standards files, UL/cUL: E48889, TUV: R50004410

DC Axial Fan
D1751S



$\phi 172 \times 51$
($\phi 6.8" \times 2.0"$)
Max. airflow : 14.2 m³/min
Max. static pressure : 640 Pa
Mass : 830 g

Fan model code

D1751S12B1AP-00

D1751S12B1AS-00

D1751S12B1AZ-00

D1751S12B2AP-00

D1751S12B2AS-00

D1751S12B2AZ-00

D1751S12B3AP-00

D1751S12B3AS-00

D1751S12B3AZ-00

D1751S12B4AP-00

D1751S12B4AS-00

D1751S12B4AZ-00

D1751S24B1AP-00

D1751S24B1AS-00

D1751S24B1AZ-00

D1751S24B2AP-00

D1751S24B2AS-00

D1751S24B2AZ-00

D1751S24B3AP-00

D1751S24B3AS-00

D1751S24B3AZ-00

D1751S24B4ZP-00

D1751S24B5ZP-00

D1751S24B6AP-00

D1751S24B6ZP-00

D1751S24B7AP-00

D1751S24B7AZ-00

D1751S24B7ZP-00

D1751S24B8ZP300

D1751S24B9ZP300

D1751S48B2AP-00

D1751S48B2AS-00

D1751S48B2AZ-00

D1751S48B3AP-00

D1751S48B3AS-00

D1751S48B3AZ-00

D1751S48B4ZP-00

D1751S48B5ZP-00

D1751S48B6ZP-00

D1751S48B7ZP-00

D1751S48B8AZ-00

D1751S48B8ZP-00

D1751S48B9ZP-00

Standard specification

| Max. airflow m ³ /min | Max. static pressure CFM | Pa | inH ₂ O | Noise dB | Speed min ⁻¹ | Voltage spec. V | | Current mA | | Model code | Operating temp. range °C | | | | | |
|-------------------------------------|-----------------------------|-----|--------------------|-------------|----------------------------|-----------------|-----------------|------------|----------|-----------------|--------------------------|-----------|-----------|-----------|-----------|-----------|
| | | | | | | Rating | Operating Range | Rating | Starting | | | | | | | |
| 14.2 | 501 | 640 | 2.75 | 68 | 6800 | 24 | 16-28 | 4600 | 6900 | D1751S24B9ZP300 | -20 ~ +60 | | | | | |
| | | | | | | 48 | 36-60 | 2300 | 6000 | D1751S48B9ZP-00 | | | | | | |
| 12.7 | 448 | 520 | 2.09 | 65 | 6100 | 24 | 16-28 | 3400 | 4800 | D1751S24B8ZP300 | | -20 ~ +60 | | | | |
| | | | | | | 48 | 36-60 | 1650 | 3500 | D1751S48B8AZ-00 | | | | | | |
| 11.4 | 402 | 435 | 1.75 | 62 | 5400 | 24 | 12-27.6 | 2450 | 5600 | D1751S24B7AZ-00 | | | -20 ~ +60 | | | |
| | | | | | | 48 | 36-60 | 1200 | 2350 | D1751S48B7ZP-00 | | | | | | |
| 10.2 | 360 | 335 | 1.35 | 59 | 4800 | 24 | 12-27.6 | 1800 | 3200 | D1751S24B6AZ-00 | | | | -20 ~ +60 | | |
| | | | | | | 48 | 36-60 | 820 | 1800 | D1751S48B6ZP-00 | | | | | | |
| 9 | 318 | 270 | 1.08 | 56 | 4200 | 24 | 12-27.6 | 1200 | 2200 | D1751S24B5ZP-00 | | | | | -20 ~ +70 | |
| | | | | | | 48 | 36-60 | 600 | 1150 | D1751S48B5ZP-00 | | | | | | |
| 8 | 282 | 220 | 0.88 | 53.5 | 3800 | 12 | 8.4-13.8 | 1840 | 3800 | D1751S12B4AZ-00 | | | | | | -20 ~ +70 |
| | | | | | | 24 | 12-27.6 | 900 | 2200 | D1751S24B4ZP-00 | | | | | | |
| 6.8 | 240 | 165 | 0.66 | 48 | 3200 | 48 | 36-60 | 450 | 860 | D1751S48B4ZP-00 | -20 ~ +70 | | | | | |
| | | | | | | 12 | 8.4-13.8 | 1200 | 3400 | D1751S12B3AZ-00 | | | | | | |
| 5.8 | 205 | 125 | 0.50 | 44 | 2800 | 24 | 12-27.6 | 600 | 2400 | D1751S24B3AZ-00 | | -20 ~ +70 | | | | |
| | | | | | | 48 | 28.8-55.2 | 310 | 900 | D1751S48B3AZ-00 | | | | | | |
| 4.2 | 148 | 70 | 0.28 | 36 | 2000 | 12 | 8.4-13.8 | 800 | 2900 | D1751S12B2AZ-00 | | | -20 ~ +70 | | | |
| | | | | | | 24 | 12-27.6 | 400 | 1900 | D1751S24B2AZ-00 | | | | | | |
| 4.2 | 148 | 70 | 0.28 | 36 | 2000 | 48 | 28.8-55.2 | 210 | 700 | D1751S48B2AZ-00 | | | | -20 ~ +70 | | |
| | | | | | | 12 | 8.4-13.8 | 390 | 2200 | D1751S12B1AZ-00 | | | | | | |
| 4.2 | 148 | 70 | 0.28 | 36 | 2000 | 24 | 12-27.6 | 200 | 1150 | D1751S24B1AZ-00 | | | | | -20 ~ +70 | |

- Figures in the table are average measured values. Please request the product delivery specification when preparing a purchase specification.
- The characteristics are the values at rated voltage (12 V, 24 V, 48 V), and normal temperature and humidity.

General specification

| | |
|--------------------|--|
| Materials Used | Venturi: Aluminum alloy die castings Propelle: ABS and PBT synthetic resins Bearing: Both side shielded ball bearing |
| Motor | Brushless DC motor, Protection type: Overcurrent detection and automatic resetting by current limiting |
| Common Elec. Spec. | See pages G-11, G-12, G-13. |
| Standard Carton | 12 to a carton of (450 x 380 x 220)mm, mass 10.5kg |

Standard airflow and static pressure characteristics (At rated voltage)

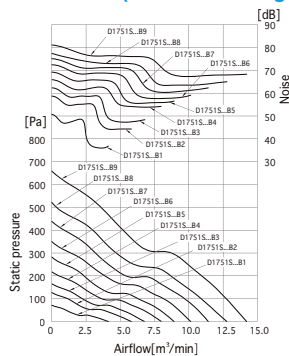

PWM speed control specification

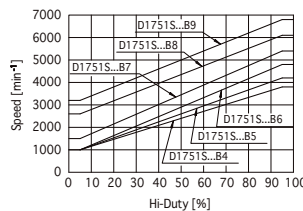

DC axial fan with sensor

| Rated Vol. | Model Code | | | | | | | | | |
|------------|-----------------|-----------------|-----------------|-----------------|-----------------|-----------------|-----------------|-----------------|-----------------|--|
| 12 V | D1751S12B1AP-00 | D1751S12B2AP-00 | D1751S12B3AP-00 | D1751S12B4AP-00 | | | | | | |
| | D1751S12B1AS-00 | D1751S12B2AS-00 | D1751S12B3AS-00 | D1751S12B4AS-00 | | | | | | |
| 24V | D1751S24B1AP-00 | D1751S24B2AP-00 | D1751S24B3AP-00 | D1751S24B4ZP-00 | D1751S24B5ZP-00 | D1751S24B6AP-00 | D1751S24B7AP-00 | D1751S24B8ZP300 | D1751S24B9ZP300 | |
| | D1751S24B1AS-00 | D1751S24B2AS-00 | D1751S24B3AS-00 | D1751S24B4ZR-13 | | D1751S24B6ZP-00 | D1751S24B7ZP-00 | | | |
| 48V | | D1751S48B2AP-00 | D1751S48B3AP-00 | D1751S48B4ZP-00 | D1751S48B5ZP-00 | D1751S48B6ZP-00 | D1751S48B7ZP-00 | D1751S48B8ZP-00 | D1751S48B9ZP-00 | |
| | | D1751S48B2AS-00 | D1751S48B3AS-00 | | | | | | | |

- NIDECE SERVO can meet many of your requirements for customization, such as special connectors, other sensors not listed above, variable speed specifications, and other modifications. Please contact NIDECE SERVO during your product planning and development stage.
- PWM (pulse width modulation) allowing for variable speed control is available in some models (reference the G-41 spec.)
- The listed products are registered in the following overseas standards files, UL/cUL: E48889, TUV: R50004410

Mouting hole dimensions in mm (inches)[Recommendation]

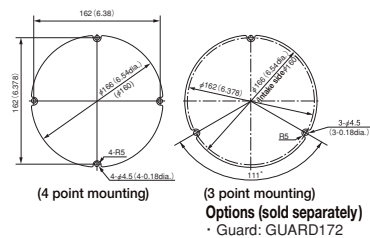

External dimensions in mm (inches)

● Lead wire type

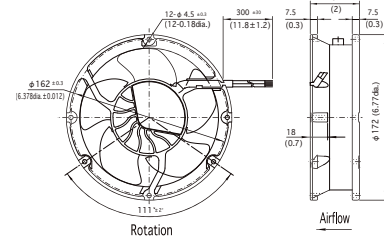

Lead wire spec. AWG24 UL3266
Color (+) Red (-) Black (Sensor) Yellow (Speed control) Blue

Speed Performance (At rated vol. Air) Specification (Room temperature)

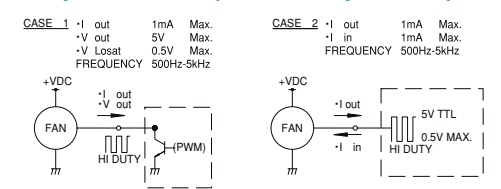

DC Axial Fan
Fixed Blade Type
G0938B



□ 92×38 (□ 3.6"×1.5")
Max. airflow : 3.9 m³/min
Max. static pressure : 490 Pa
Mass : 320 g

Fan model code

- G0938B12B8ZP-00
- G0938B12B9ZP-00
- G0938B12BAZP-00
- G0938B24B8ZP-00
- G0938B24B9ZP-00
- G0938B24BAZP-00
- G0938B48B8ZP-00
- G0938B48B9ZP-00
- G0938B48BAZP-00

Standard specification

| Max. airflow | | Max. static pressure | | Noise dB | Speed min ⁻¹ | | Voltage spec. V | | Current mA | | Model code | Operating Temp. Range°C |
|---------------------|-----|----------------------|--------------------|----------|-------------------------|------|-----------------|-----------------|------------|----------|-----------------|-------------------------|
| m ³ /min | CFM | Pa | inH ₂ O | | Max. | Min. | Rating | Operating Range | Rating | Starting | | |
| 3.9 | 138 | 490 | 1.97 | 63 | 7500 | 2100 | 12 | 8.4-13.2 | 2600 | 4900 | G0938B12BAZP-00 | -20 ~ +60 |
| | | | | | | | 24 | 16.8-26.4 | 1300 | 2700 | G0938B24BAZP-00 | |
| | | | | | | | 48 | 36-52.8 | 610 | 1360 | G0938B48BAZP-00 | |
| 3.6 | 127 | 440 | 1.77 | 61 | 7000 | 2000 | 12 | 8.4-13.8 | 2000 | 4600 | G0938B12B9ZP-00 | |
| | | | | | | | 24 | 16.8-27.6 | 1000 | 2600 | G0938B24B9ZP-00 | |
| | | | | | | | 48 | 36-55.2 | 520 | 1100 | G0938B48B9ZP-00 | |
| 3.2 | 113 | 350 | 1.41 | 58 | 6300 | 1600 | 12 | 8.4-13.8 | 1500 | 3800 | G0938B12B8ZP-00 | -20 ~ +70 |
| | | | | | | | 24 | 16.8-27.6 | 700 | 2000 | G0938B24B8ZP-00 | |
| | | | | | | | 48 | 36-55.2 | 360 | 840 | G0938B48B8ZP-00 | |

- Figures in the table are average measured values. Please request the product delivery specification when preparing a purchase specification.
- The characteristics are the values at rated voltage (12 V, 24 V, or 48 V), and normal temperature and humidity.
- Max. CFM and max static pressure points conclude at max rotational speed.

General specification

| | |
|--------------------|---|
| Materials Used | Venturi: Aluminum alloy die castings Propeller: ABS and PBT synthetic resins Bearing: Both side shielded ball bearing |
| Motor | Brushless DC motor, Protection type: Current shut off by detecting lock state, automatically reset |
| Common Elec. Spec. | See pages G-11, G-12, G-13. |

Standard airflow and static pressure characteristics (At rated voltage)

[By double chamber method]

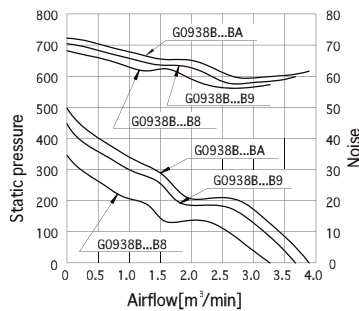

PWM speed control specification (At rated voltage)

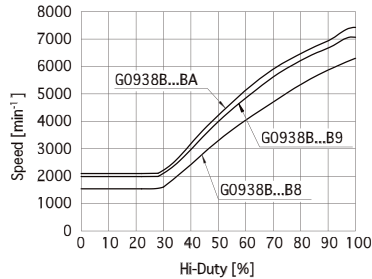

Mounting hole dimensions in mm (inches)
[Recommendation]

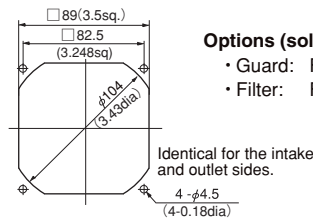

Options (sold separately)

- Guard: F92UL guard
- Filter: F92 filter

Identical for the intake and outlet sides.

External dimensions in mm (inches)

● Lead wire type

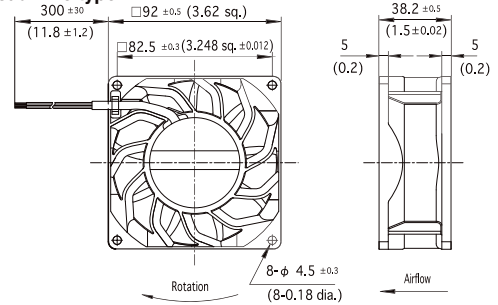

Lead wire spec. AWG24 UL3266
Color (+) Red
(-) Black
(Sensor) Yellow
(Speed control) Blue

Speed performance (At rated vol., Air) specification (Room temperature)

CASE 1 • I out 1mA Max.
• V out 5V Max.
• V Losat 0.5V Max.
FREQUENCY 500kHz-5kHz

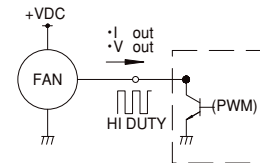

CASE 2 • I out 1mA Max.
• I in 1mA Max.
FREQUENCY 500kHz-5kHz

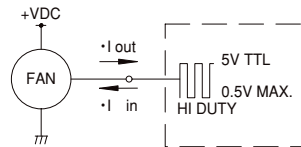

- NIDEC SERVO can meet many of your requirements for customization, such as special connectors, other sensors not listed above, variable speed specifications, and other modifications. Please contact NIDEC SERVO during your product planning and development stage.
- The listed products are registered in the following overseas standards files, UL/cUL: E48889, TUV: R50004410

DC Axial Fan
Fixed Blade Type
G1238B



□ 119×38 (□ 4.7"×1.5")
Max. airflow : 7.4 m³/min
Max. static pressure : 520 Pa
Mass : 480 g

Fan model code

G1238B12BAZP-00

G1238B12BBZP-00

G1238B24BAZP-00

G1238B24BBZP-00

G1238B48BAZP-00

G1238B48BBZP-00

Standard specification

| Max. airflow | | Max. static pressure | | Noise dB | Speed min ⁻¹ | | Voltage spec. V | | Current mA | | Model code | Operating temp. range °C |
|---------------------|-----|----------------------|--------------------|-------------|-------------------------|------|-----------------|-----------------|------------|----------|-----------------|-----------------------------|
| m ³ /min | CFM | Pa | inH ₂ O | | Max. | Min. | Rating | Operating Range | Rating | Starting | | |
| 7.4 | 261 | 520 | 2.09 | 67 | 6300 | 1000 | 12 | 9.6-13.8 | 4450 | 6100 | G1238B12BBZP-00 | -20 ~ +60 |
| | | | | | | | 24 | 16.8-27.6 | 2200 | 3100 | G1238B24BBZP-00 | |
| | | | | | | | 48 | 36-55.2 | 1100 | 1600 | G1238B48BBZP-00 | |
| 6.3 | 223 | 415 | 1.67 | 64 | 5300 | 1000 | 12 | 9.6-13.8 | 2800 | 3900 | G1238B12BAZP-00 | -20 ~ +70 |
| | | | | | | | 24 | 16.8-27.6 | 1300 | 2000 | G1238B24BAZP-00 | |
| | | | | | | | 48 | 36-55.2 | 660 | 970 | G1238B48BAZP-00 | |

- NIDEC SERVO can meet many of your requirements for customization, such as special connectors, other sensors not listed above, variable speed specifications, and other modifications. Please contact NIDEC SERVO during your product planning and development stage.
- The listed products are registered in the following overseas standards files, UL/cUL: E48889, TUV: R50004410

General specification

| | |
|--------------------|---|
| Materials Used | Venturi: Venturi: Aluminum alloy die castings. Propeller: ABS and PBT synthetic resins Bearing: Both side shielded ball bearing |
| Motor | Brushless DC motor, Protection type: Current shut off by detecting lock state, automatically reset |
| Common Elec. Spec. | See pages G-11, G-12, G-13. |

Standard airflow and static pressure characteristics (At rated voltage)
[By double chamber method]

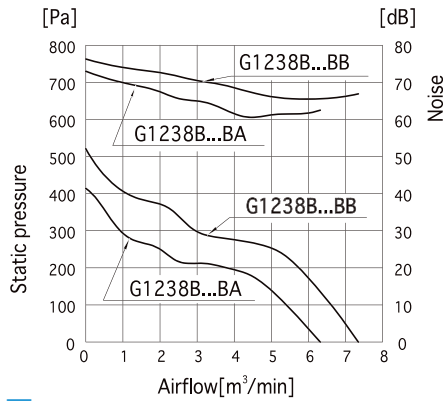

PWM speed control specification (At rated voltage)

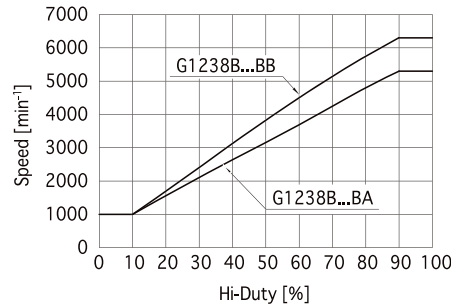

Mounting hole dimensions in mm (inches)
[Recommendation]

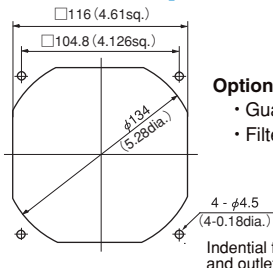

Options (sold separately)

- Guard: F120UL guard
- Filter: F120 filter

Indential for the intake and outlet sides.

- NIDEC SERVO can meet many of your requirements for customization, such as special connectors, other sensors not listed above, variable speed specifications, and other modifications. Please contact NIDEC SERVO during your product planning and development stage.
- The listed products are registered in the following overseas standards files, UL/cUL: E48889, TUV: R50004410

External dimensions in mm (inches)

● Lead wire type

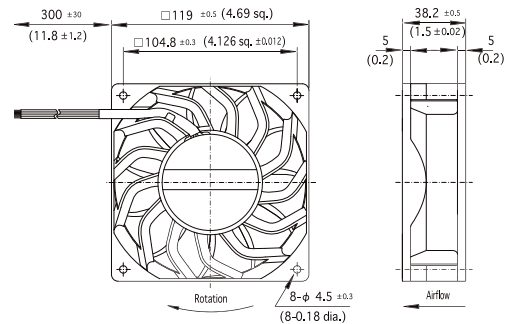

Lead wire spec. AWG22 UL3266

- Color (+) Red (-) Black (Sensor) Yellow (Speed control) Blue

Speed performance (At rated vol., Air) specification (Room temperature)

CASE 1 · I out 1mA Max.
· V out 5V Max.
· V Losat 0.5V Max.
FREQUENCY 500kHz-5kHz

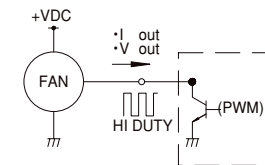

CASE 2 · I out 1mA Max.
· I in 1mA Max.
FREQUENCY 500kHz-5kHz

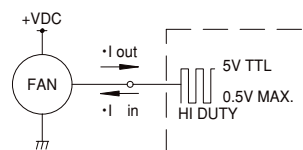

For a High Static Pressure Region
DC Axial Fan
Fixed Blade Type
G1751M



$\phi 172 \times 150 \times 51$
($\phi 6.8'' \times 6.0'' \times 2.0''$)
Max. airflow: 11.2 m³/min
Max. static pressure: 840 Pa
Mass: 820 g

Fan model code

- G1751M24B5ZP-00
- G1751M24B6ZP-00
- G1751M24B7ZP-00
- G1751M24B8ZP300
- G1751M24B9ZP300
- G1751M48B5ZP-00
- G1751M48B6ZP-00
- G1751M48B7ZP-00
- G1751M48B8ZP-00
- G1751M48B9ZP-00

High static pressure fans suitable for cooling densely assembled equipment.

Standard specification

| Max. airflow | | Max. static pressure | | Noise dB | Speed min ⁻¹ | | Voltage spec. V | | Current mA | | Model code | Operating temp. range °C |
|---------------------|-----|----------------------|--------------------|------------------------------|-------------------------|------|-----------------|-----------------|------------|----------|-----------------|--------------------------|
| m ³ /min | CFM | Pa | inH ₂ O | | Max. | Min. | Rating | Operating Range | Rating | Starting | | |
| 11.2 | 395 | 780 | 3.13 | 74(7.9m ³ /min) | 6800 | 3200 | 24 | 16-28 | 4800 | 6900 | G1751M24B9ZP300 | -20 ~ +60 |
| | | 840 | 3.37 | | | | 48 | 36-60 | 2500 | 6000 | | |
| 10 | 353 | 710 | 2.85 | 71(9m ³ /min) | 6200 | 2600 | 24 | 16-28 | 3600 | 5100 | G1751M24B8ZP300 | |
| | | | | | | | 48 | 36-60 | 1800 | 3500 | G1751M48B8ZP-00 | |
| 9.2 | 325 | 580 | 2.33 | 69(6.7m ³ /min) | 5600 | 2000 | 24 | 12-27.6 | 2850 | 6100 | G1751M24B7ZP-00 | |
| | | | | | | | 48 | 36-60 | 1360 | 2650 | G1751M48B7ZP-00 | |
| 8.3 | 293 | 490 | 1.97 | 66.5(6.1m ³ /min) | 5100 | 1500 | 24 | 12-27.6 | 2250 | 3800 | G1751M24B6ZP-00 | |
| | | | | | | | 48 | 36-60 | 1040 | 2100 | G1751M48B6ZP-00 | |
| 7.3 | 258 | 360 | 1.45 | 63(5.3m ³ /min) | 4500 | 1500 | 24 | 12-27.6 | 1500 | 2800 | G1751M24B5ZP-00 | |
| | | | | | | | 48 | 36-60 | 700 | 1400 | G1751M48B5ZP-00 | |

- Figures in the table are average measured values. Please request the product delivery specification when preparing a purchase specification.
- The characteristics are the values at rated voltage (12 V), and normal temperature and humidity.
- Max. CFM and max static pressure points conclude at max rotational speed.

General specification

| | |
|--------------------|---|
| Materials Used | Venturi: Aluminum alloy die castings Propeller: ABS and PBT synthetic resins Bearing: Both side shielded ball bearing |
| Motor | Brushless DC motor, Protection type: Overcurrent detection and automatic resetting by current limiting |
| Common Elec. Spec. | See pages G-11, G-12, G-13. |
| Standard Carton | 12 to a carton of (450 x 380 x 220) mm, mass 11 kg |

Standard airflow and static pressure characteristics (At rated voltage)
[By double chamber method]

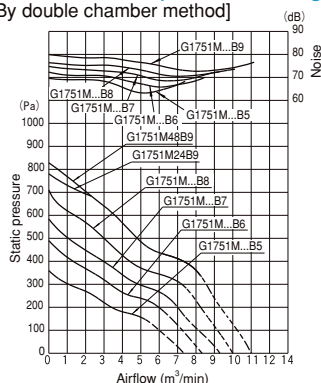

External dimensions in mm (inches)

● Lead wire type

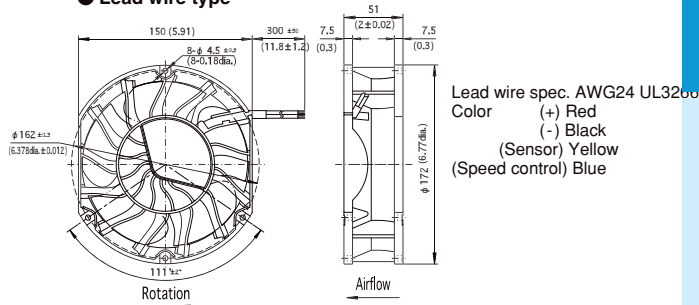

PWM speed control specification

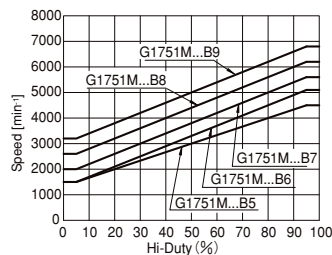

Speed performance (At rated vol., Air specification (Room temperature))

CASE 1
· I out 1mA Max.
· V out 5V Max.
· V Losat 0.5V Max.
FREQUENCY 500kHz-5kHz

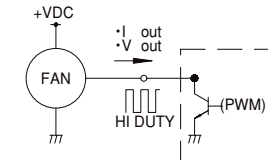

CASE 2
· I out 1mA Max.
· I in 1mA Max.
FREQUENCY 500kHz-5kHz

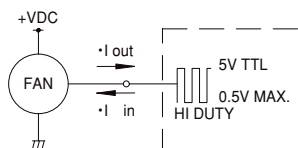

Mounting hole dimensions in mm (inches)
[Recommendation]

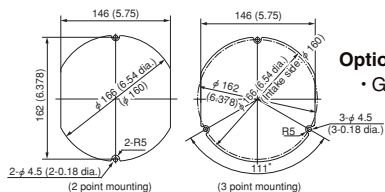

Options (sold separately)
· Guard: GUARD172

- NIDEC SERVO can meet many of your requirements for customization, such as special connectors, other sensors not listed above, variable speed specifications, and other modifications. Please contact NIDEC SERVO during your product planning and development stage.
- The listed products are registered in the following overseas standards files, UL/cUL: E48889, TUV: R50004410

DC Centrifugal
Blowers
E0515H

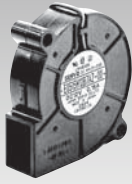

51 × 53 × 15
(2.0" × 2.1" × 0.6")
Max. airflow: 0.125 m³/min
Max. static pressure: 210 Pa
Mass: 30 g

Fan model code

E0515H12B3AZ-00

E0515H12B5AS-00

E0515H12B5AZ-00

E0515H12B7APA01

E0515H12B7ASA01

E0515H12B7AZA01

E0515H12B8APA01

E0515H12B8ASA01

E0515H12B8AZA01

E0515H24B5AP-01

E0515H24B5AS-01

E0515H24B5AZ-00

E0515H24B7APA01

E0515H24B7AZA01

E0515H24B8ASA01

E0515H24B8AZA01

Standard specification

| Max. Airflow m ³ /min | Max. Static Pressure CFM | Max. Static Pressure | | Noise dB | Speed min ⁻¹ | Input W | Voltage Spec. V | | Current mA | | Model Code | Operating Temp. Range °C |
|-------------------------------------|-----------------------------|----------------------|--------------------|-------------|----------------------------|------------|-----------------|-----------------|------------|----------|-----------------|-----------------------------|
| | | Pa | inH ₂ O | | | | Rating | Operating Range | Rating | Starting | | |
| 0.125 | 4.4 | 210 | 0.84 | 42 | 6100 | 2.3 | 12 | 6-13.8 | 190 | 320 | E0515H12B8AZA01 | -20 ~ +60 |
| | | | | | | | 24 | 12-27.6 | 100 | 160 | E0515H24B8AZA01 | |
| 0.11 | 3.9 | 165 | 0.66 | 40 | 5500 | 1.7 | 12 | 6-13.8 | 140 | 225 | E0515H12B7AZA01 | -20 ~ +80 |
| | | | | | | | 24 | 12-27.6 | 80 | 130 | E0515H24B7AZA01 | |
| 0.1 | 3.5 | 135 | 0.54 | 37 | 5000 | 1.4 | 12 | 9.6-13.8 | 120 | 190 | E0515H12B5AZ-00 | -20 ~ +60 |
| | | | | | | | 24 | 16.8-27.6 | 60 | 110 | E0515H24B5AZ-00 | |
| 0.09 | 3.2 | 110 | 0.44 | 34 | 4500 | 1.1 | 12 | 9.6-13.8 | 90 | 150 | E0515H12B3AZ-00 | |
| | | | | | | | 24 | 16.8-27.6 | 60 | 110 | E0515H24B3AZ-00 | |

- Figures in the table are average measured values. Please request the product delivery specification when preparing a purchase specification.
- The characteristics are the values at rated voltage (12 V or 24 V), and normal temperature and humidity.
- The life expectancy of E0515H-8 speed products at rated voltage and in continuous operation is 20,000 hours at 60°C. (30,000 hours for other products)

General specification

| | |
|--------------------|---|
| Materials Used | Venturi: ABS and PBT synthetic resins Impeller: ABS and PBT synthetic resins Bearing: Both side shielded ball bearing |
| Motor | Brushless DC motor, Protection type: Current shut off by detecting lock state, automatically reset |
| Common Elec. Spec. | See pages G-11, G-12, G-13. |

Standard airflow and static pressure characteristics (At rated voltage)

[By double chamber method]

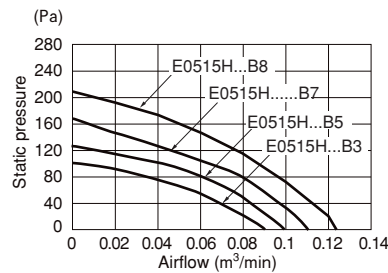

External dimensions in mm (inches)

Lead wire type

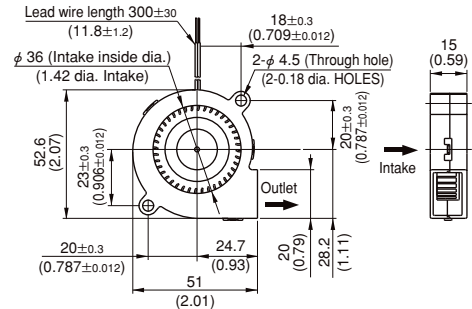

Lead wire spec. UL1061 AWG26 or UL3265 AWG26
Color (+) Red
(-) Black

Wiring connection diagram

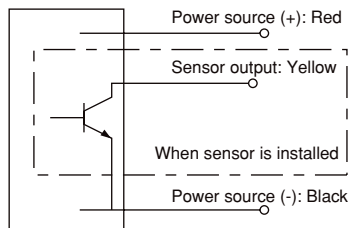

DC centrifugal blower with sensor

| Rated Vol. | Model Code | | |
|------------|-----------------|-----------------|-----------------|
| 12 V | E0515H12B5AS-00 | E0515H12B7ASA01 | E0515H12B8ASA01 |
| | | E0515H12B7APA01 | E0515H12B8APA01 |
| 24 V | E0515H24B5AS-00 | | E0515H24B8ASA01 |
| | E0515H24B5AP-00 | E0515H24B7APA01 | |

- NIDEC SERVO can meet many of your requirements for customization, such as special connectors, other sensors not listed above and other modifications. Please contact NIDEC SERVO during your product planning and development stage.
- The listed products are registered in the following overseas standards files, UL: E48889, CSA: LR49399, TUV: R9451586
- 3D data is also available at our web2-CAD site (www.cadenas.co.jp).

Super Silent Blowers

E0720H



70×76×20
(2.8"×3.0"×0.8")
Max. airflow: 0.29 m³/min
Max. static pressure: 300 Pa
Mass: 50 g

Fan model code

- E0720H12B5AP-00
- E0720H12B5AS-00
- E0720H12B5AZ-00
- E0720H12B7AP-00
- E0720H12B7AS-00
- E0720H12B7AZ-00
- E0720H12B7CZ-00
- E0720H12B8AP-00
- E0720H12B8AS-00
- E0720H12B8AZ-00
- E0720H24B5AP-00
- E0720H24B5AZ-00
- E0720H24B7AZ-00
- E0720H24B8AP-00
- E0720H24B8AS-00
- E0720H24B8AZ-00

Standard specification

| Max. Airflow | | Max. Static Pressure | | Noise dB | Speed min ⁻¹ | Voltage Spec. V | | Current mA | | Model Code | Operating Temp. Range °C |
|---------------------|------|----------------------|--------------------|-------------|----------------------------|-----------------|-----------------|------------|----------|-----------------|-----------------------------|
| m ³ /min | CFM | Pa | inH ₂ O | | | Rating | Operating Range | Rating | Starting | | |
| 0.29 | 10.2 | 300 | 1.21 | 44 | 4750 | 12 | 5-13.8 | 300 | 580 | E0720H12B8AZ-00 | -20 ~ +70 |
| | | | | | | 24 | 10-27.6 | 140 | 270 | E0720H24B8AZ-00 | |
| 0.27 | 9.5 | 250 | 1.01 | 42 | 4400 | 12 | 5-13.8 | 240 | 480 | E0720H12B7AZ-00 | |
| | | | | | | 24 | 10-27.6 | 120 | 240 | E0720H24B7AZ-00 | |
| 0.25 | 8.8 | 210 | 0.84 | 40 | 4050 | 12 | 5.5-13.8 | 200 | 390 | E0720H12B5AZ-00 | |
| | | | | | | 24 | 10-27.6 | 100 | 200 | E0720H24B5AZ-00 | |

- Figures in the table are average measured values. Please request the product delivery specification when preparing a purchase specification.
- The characteristics are the values at rated voltage (12 V or 24 V), and normal temperature and humidity.
- Life expectancy of the E0720H-8 series in continuous operation at rated voltage is 20,000 hours at an operating temperature of 60°C. (25,000 hours for other products)

General specification

| | |
|--------------------|---|
| Materials Used | Venturi: ABS and PBT synthetic resins Impeller: ABS and PBT synthetic resins Bearing: Both side shielded ball bearing |
| Motor | Brushless DC motor, Protection type: Current shut off by detecting lock state, automatically reset |
| Common Elec. Spec. | See pages G-11, G-12, G-13. |
| Standard Carton | 150 to a carton of (450 x 380 x 295) mm, mass 8 kg |

Standard airflow and static pressure characteristics (At rated voltage)

[By double chamber method]

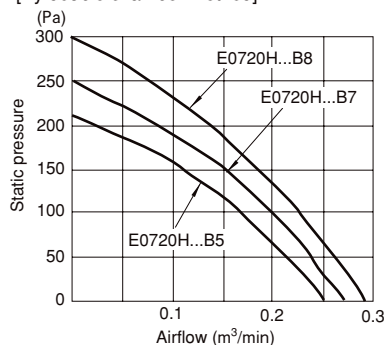

External dimensions in mm (inches)

● Lead wire type

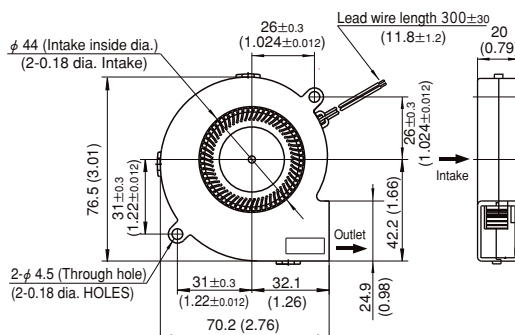

Lead wire spec. AWG26 UL3265

Color (+) Red
(-) Black

Wiring connection diagram

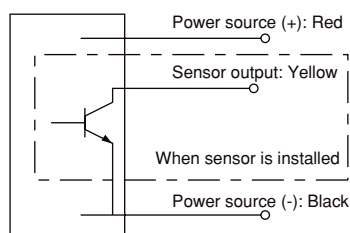

Super silent blower with sensor

| Rated Vol. | Model Code | | |
|------------|-----------------|-----------------|-----------------|
| 12 V | E0720H12B5AS-00 | E0720H12B7AS-00 | E0720H12B8AS-00 |
| | E0720H12B5AP-00 | E0720H12B7AP-00 | E0720H12B8AP-00 |
| 24 V | E0720H24B5AP-00 | | E0720H24B8AS-00 |
| | | | E0720H24B8AP-00 |

- NIDEC SERVO can meet many of your requirements for customization, such as special connectors, other sensors not listed above, variable speed specifications, and other modifications. Please contact NIDEC SERVO during your product planning and development stage.
- The listed products are registered in the following overseas standards files, UL: E48889, CSA: LR49399, TUV: R50004410

DC Centrifugal
Blowers
SFBD



□ 94 × 30 (□ 3.7" × 1.2")
Max. airflow: 0.65 m³/min
Max. static pressure: 280 Pa
Mass: 135 g

Fan model code

- SFBD12B4
- SFBD12H7
- SFBD12Z7
- SFBD12Z7P
- SFBD24B4
- SFBD24H7
- SFBD24H7C
- SFBD24H7S
- SFBD24Z7
- SFBD24Z7P
- SFBD24Z7S

Standard specification

| Max. Airflow m ³ /min | Max. Static Pressure CFM | Noise Pa | Speed inH ₂ O | Noise dB | Speed min ⁻¹ | Input | | Voltage Spec. V | | Current mA | | Model Code | Operating Temp. Range °C |
|-------------------------------------|-----------------------------|-------------|-----------------------------|-------------|----------------------------|-------|---------|-----------------|-----------------|------------|----------|------------|-----------------------------|
| | | | | | | W | Rating | Rating | Operating Range | Rating | Starting | | |
| 0.65 | 23 | 280 | 1.13 | 53 | 3900 | 7.8 | 12 | 7.2-13.8 | 650 | 1600 | SFBD12H7 | -20 ~ +60 | |
| | | | | | | 7.9 | 24 | 12-27.6 | 330 | 810 | SFBD24H7 | | |
| 0.56 | 20 | 200 | 0.80 | 49 | 3300 | 5.0 | 12 | 7.2-13.8 | 440 | 1120 | SFBD12Z7 | | |
| | | | | | | 5.5 | 24 | 12-27.6 | 300 | 600 | SFBD24Z7 | | |
| 0.44 | 16 | 120 | 0.48 | 45 | 2700 | 3.5 | 12 | 7.2-13.8 | 290 | 630 | SFBD12B4 | | |
| | | | | | | 24 | 12-27.6 | 150 | 330 | SFBD24B4 | | | |

- Figures in the table are average measured values. Please request the product delivery specification when preparing a purchase specification.
- The characteristics are the values at rated voltage (12 V or 24 V), and normal temperature and humidity.
- The life expectancy of SFBD-H speed products at rated voltage and in continuous operation is 30,000 hours at 60 °C. (40,000 hours for other products)

General specification

| | |
|--------------------|---|
| Materials Used | Venturi: ABS and PBT synthetic resins Impeller: ABS and PBT synthetic resins Bearing: Both side shielded ball bearing |
| Motor | Brushless DC motor, Protection type: Current shut off by detecting lock state, automatically reset |
| Common Elec. Spec. | See pages G-11, G-12, G-13. |
| Standard Carton | 60 to a carton of (450 x 380 x 220) mm, mass 9 kg |

Standard airflow and static pressure characteristics (At rated voltage)

[By double chamber method]

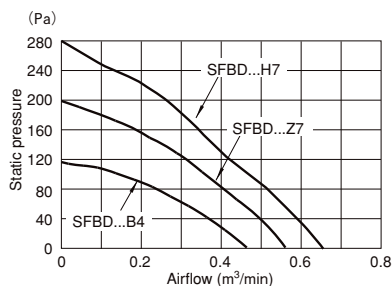

External dimensions in mm (inches)

Lead wire type

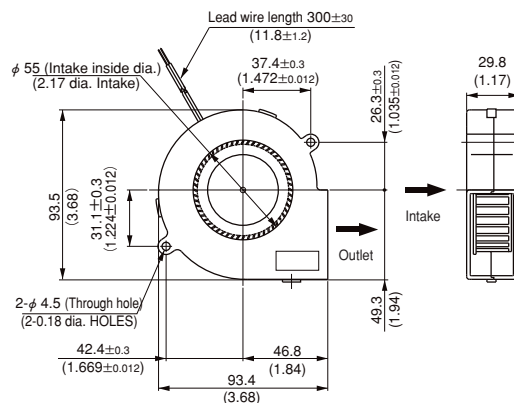

Lead wire spec. AWG24 UL1007 or UL3266
Color (+) Red
(-) Black

Wiring connection diagram

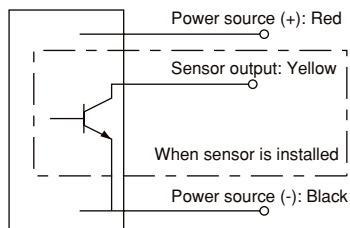

DC centrifugal blower with sensor

| Rated Vol. | Model Code | |
|------------|------------|-----------|
| 12 V | SFBD12Z7P | |
| 24 V | SFBD24Z7S | SFBD24H7S |
| | SFBD24Z7P | |

- NIDEC SERVO can meet many of your requirements for customization, such as special connectors, other sensors not listed above, variable speed specifications, and other modifications. Please contact NIDEC SERVO during your product planning and development stage.
- The listed products are registered in the following overseas standards files, UL: E48889, CSA: LR49399, TUV: R9451586
- Customizing to the sleeve bearing specification also accepted depending on the intended purchase quantity. Contact NIDEC SERVO for further information.
- 3D data is also available at our web2-CAD site (www.cadenas.co.jp).

Super Silent Blowers

E1027H



97×95×25
(3.8"×3.7"×1.0")
Max. airflow: 0.78 m³/min
Max. static pressure: 520 Pa
Mass: 125 g (~7), 150 g (~A)

Fan model code

- E1027H12B7AP-00
- E1027H12B7AS-00
- E1027H12B7AZ-00
- E1027H12BAAP-00
- E1027H12BAAS-00
- E1027H12BAAZ-00

Standard specification

| Max. Airflow | | Max. Static Pressure | | Noise dB | Speed min ⁻¹ | Voltage Spec. V | | Current mA | | Model Code | Operating Temp. Range °C |
|---------------------|-----|----------------------|--------------------|-------------|----------------------------|-----------------|-----------------|------------|----------|------------------------|-----------------------------|
| m ³ /min | CFM | Pa | inH ₂ O | | | Rating | Operating Range | Rating | Starting | | |
| 0.78 | 28 | 520 | 2.09 | 55 | 5000 | 12 | 8.4-13.8 | 1000 | 2200 | E1027H12BAAZ-00 | -20 ~ +60 |
| 0.57 | 20 | 315 | 1.27 | 47 | 3600 | | 5.0-13.2 | 550 | 1670 | E1027H12B7AZ-00 | -20 ~ +70 |

- Figures in the table are average measured values. Please request the product delivery specification when preparing a purchase specification.
- The characteristics are the values at rated voltage (12 V), and normal temperature and humidity.

General specification

| | |
|--------------------|---|
| Materials Used | Venturi: ABS and PBT synthetic resins Impeller: ABS and PBT synthetic resins Bearing: Both side shielded ball bearing |
| Motor | Brushless DC motor, Protection type: Current shut off by detecting lock state, automatically reset |
| Common Elec. Spec. | See pages G-11, G-12, G-13. |

Standard airflow and static pressure characteristics (At rated voltage)

[By double chamber method]

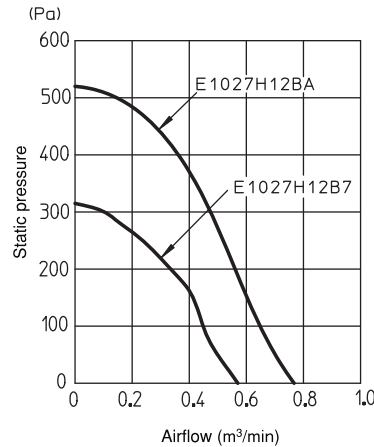

External dimensions in mm (inches)

● Lead wire type

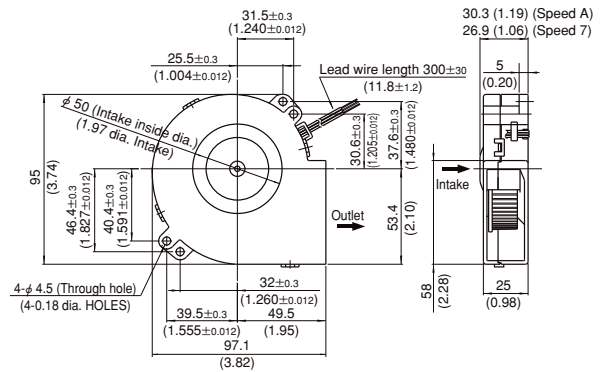

Lead wire spec. AWG24 UL3266
Color (+) Red
(-) Black

Wiring connection diagram

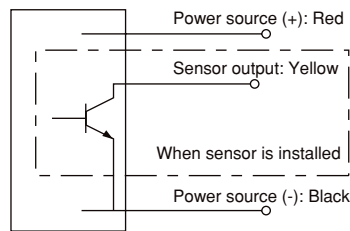

Super silent blower with sensor

| Rated Vol. | Model Code | |
|------------|------------------------|------------------------|
| 12 V | E1027H12B7AS-00 | E1027H12BAAS-00 |
| | E1027H12B7AP-00 | E1027H12BAAP-00 |

- NIDEC SERVO can meet many of your requirements for customization, such as special connectors, other sensors not listed above, variable speed specifications, and other modifications. Please contact NIDEC SERVO during your product planning and development stage.
- The listed products are registered in the following overseas standards files, UL/CUL: E48889, TUV: R50004410

Super Silent Blowers
E1033H/L



97×95×33

(3.8"×3.7"×1.3")

Max. airflow: 1.55m³/min
Max. static pressure: 1400 Pa
Mass: 140 g (~8), 160 g (~A), 170g(~F)

Fan model code

- E1033H12B7AP-00
- E1033H12B7AZ-00
- E1033H12B8AS-00
- E1033H12B8AZ-00
- E1033H12BAAZ-00
- E1033L12BBAZ-00
- E1033L12BCAZ-00
- E1033L12BEZP-00
- E1033L12BFZP-00
- E1033H24B6AZ-00
- E1033H24B7AZ-00
- E1033H24B8AZ-00
- E1033H24BAAP-00
- E1033H24BAAZ-00
- E1033L24BBAZ-00
- E1033L24BCAZ-00

Standard specification

| Max. Airflow | | Max. Static Pressure | | Noise | Speed | Voltage spec.V | | CurrentmA | | Model Code | Operating Temp. Range °C |
|---------------------|-----|----------------------|--------------------|-------|-------|----------------|-----------------|-----------|----------|-----------------|--------------------------|
| m ³ /min | CFM | Pa | inH ₂ O | dB | r/min | Rating | Operating Range | Rating | Starting | | |
| 1.55 | 55 | 1400 | 5.63 | 66 | 6900 | 12 | 10.8 - 12.6 | 3500 | 6300 | E1033L12BFZP-00 | -20 ~ +70 |
| 1.45 | 51 | 1200 | 4.82 | 64 | 6400 | 12 | 10.8 - 13.2 | 2940 | 6350 | E1033L12BEZP-00 | |
| 1.25 | 44 | 840 | 3.36 | 62 | 5800 | 12 | 8.4 - 13.2 | 1950 | 3100 | E1033L12BCAZ-00 | |
| | | | | | | 24 | 12 - 26.4 | 950 | 1650 | E1033L24BCAZ-00 | |
| 1.15 | 41 | 700 | 2.81 | 60 | 5300 | 12 | 8.4 - 13.2 | 1400 | 3100 | E1033L12BBAZ-00 | -20 ~ +60 |
| | | | | | | 24 | 12 - 26.4 | 700 | 1650 | E1033L24BBAZ-00 | |
| 1.14 | 40 | 500 | 2.01 | 58 | 4850 | 12 | 8.4 - 13.2 | 1250 | 2100 | E1033H12BAAZ-00 | |
| | | | | | | 24 | 12 - 26.4 | 630 | 1850 | E1033H24BAAZ-00 | |
| 0.85 | 30 | 320 | 1.29 | 51 | 3450 | 12 | 4.5 - 13.2 | 770 | 1950 | E1033H12B8AZ-00 | -20 ~ +70 |
| | | | | | | 24 | 10 - 26.4 | 390 | 940 | E1033H24B8AZ-00 | |
| 0.76 | 27 | 260 | 1.05 | 48 | 3100 | 12 | 5 - 13.2 | 590 | 1260 | E1033H12B7AZ-00 | |
| | | | | | | 24 | 10 - 26.4 | 300 | 710 | E1033H24B7AZ-00 | |
| 0.64 | 23 | 185 | 0.74 | 46 | 2600 | 24 | 10 - 26.4 | 220 | 400 | E1033H24B6AZ-00 | |

- Figures in the table are average measured values. Please request the product delivery specification when preparing a purchase specification.
- The characteristics are the values at rated voltage (12 V or 24 V), and normal temperature and humidity.

General specification

| | |
|--------------------|--|
| Materials Used | Venturi: ABS and PBT synthetic resins *1 Impeller: ABS and PBT synthetic resins *2 Bearing: Both side shielded ball bearing |
| Motor | Brushless DC motor, Protection type: Current shut off by detecting lock state, automatically reset |
| Common Elec. Spec. | See pages G-11, G-12, G-13. |
| Standard Carton | 50 to a carton of (450 x 380 x 220) mm, mass 8 kg *3 *1 E1033L Venturi: PBT synthetic resins *2 E1033L Impeller: PBT synthetic resins *3 E1033L 40 to a carton of (450 x 380 x 220) mm, mass 8 kg |

External dimensions in mm (inches)

- Lead wire type (E1033H/L)
Lead wire spec. AWG24 UL3266 or AWG22 UL3266
Color (+) Red
(-) Black

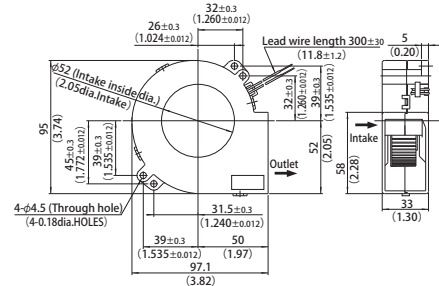

Standard airflow and static pressure characteristics (At rated voltage)

[By double chamber method]

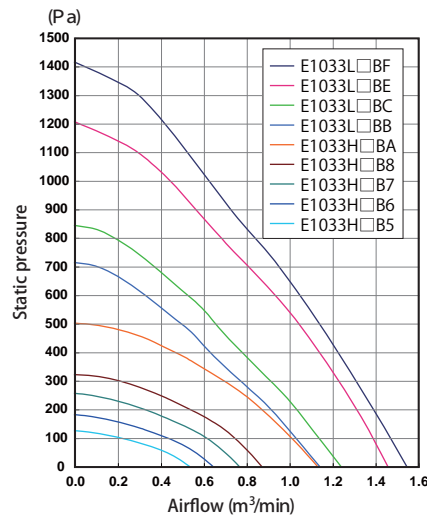

Wiring connection diagram

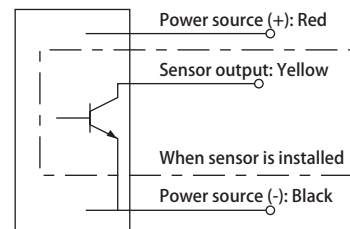

Super silent blower with sensor

| Rated Vol. | Model Code | | |
|------------|-----------------|-----------------|-----------------|
| 12 V | E1033H12B7AP-00 | E1033H12B8AS-00 | |
| 24 V | | | E1033H24BAAP-00 |

- NIDEC SERVO can meet many of your requirements for customization, such as special connectors, other sensors not listed above, variable speed specifications, and other modifications. Please contact NIDEC SERVO during your product planning and development stage.
- The listed products are registered in the following overseas standards files, UL/cUL: E48889, TUV: R50004410
- PWM (pulse width modulation) allowing for variable speed control is available in some models.

Super Silent Blowers
E1232L



119×117×32
(4.7"×4.6"×1.3")
Max. airflow: 1.13 m³/min
Max. static pressure: 460 Pa
Mass: 220 g

Fan model code

E1232L12B5AP-00

E1232L12B5AS-00

E1232L12B5AZ-00

E1232L12B6AP-00

E1232L12B6AS-00

E1232L12B6AZ-00

E1232L12B7AP-00

E1232L12B7AS-00

E1232L12B7AZ-00

E1232L12B9AP-00

E1232L12B9AS-00

E1232L12B9AZ-00

E1232L24B5AP-00

E1232L24B5AS-00

E1232L24B5AZ-00

E1232L24B6AP-00

E1232L24B6AS-00

E1232L24B6AZ-00

E1232L24B7AP-00

E1232L24B7AS-00

E1232L24B7AZ-00

E1232L24B9AP-00

E1232L24B9AS-00

E1232L24B9AZ-00

Standard specification

| Max. Airflow | | Max. Static Pressure | | Noise dB | Speed min ⁻¹ | Voltage Spec. V | | Current mA | | Model Code | Operating Temp. Range °C | |
|---------------------|-----|----------------------|--------------------|-------------|----------------------------|-----------------|-----------------|------------|----------|-----------------|-----------------------------|-----------|
| m ³ /min | CFM | Pa | inH ₂ O | | | Rating | Operating Range | Rating | Starting | | | |
| 1.13 | 40 | 460 | 1.85 | 54 | 3800 | 12 | 8.4-13.2 | 1100 | 2100 | E1232L12B9AZ-00 | -20 ~ +60 | |
| | | | | | | 24 | 21.6-26.4 | 560 | 1900 | E1232L24B9AZ-00 | | |
| 0.91 | 32 | 320 | 1.29 | 49 | 3100 | 12 | 7.2-13.2 | 820 | 1800 | E1232L12B7AZ-00 | | |
| | | | | | | 24 | 12-26.4 | 430 | 900 | E1232L24B7AZ-00 | | |
| 0.83 | 29 | 250 | 1.01 | 47 | 2750 | 12 | 7.2-13.2 | 560 | 1300 | E1232L12B6AZ-00 | | -20 ~ +70 |
| | | | | | | 24 | 12-26.4 | 310 | 700 | E1232L24B6AZ-00 | | |
| 0.75 | 26 | 200 | 0.80 | 44 | 2450 | 12 | 7.2-13.2 | 420 | 940 | E1232L12B5AZ-00 | | |
| | | | | | | 24 | 12-26.4 | 250 | 490 | E1232L24B5AZ-00 | | |

- Figures in the table are average measured values. Please request the product delivery specification when preparing a purchase specification.
- The characteristics are the values at rated voltage (12 V or 24 V), and normal temperature and humidity.
- The life expectancy of E1232L-7, 9 speed products at rated voltage and in continuous operation is 30,000 hours at 60°C. (40,000 hours for other products)

General specification

| | |
|--------------------|---|
| Materials Used | Venturi: ABS and PBT synthetic resins Impeller: ABS and PBT synthetic resins Bearing: Both side shielded ball bearing |
| Motor | Brushless DC motor, Protection type: Current shut off by detecting lock state, automatically reset |
| Common Elec. Spec. | See pages G-11, G-12, G-13. |

Standard airflow and static pressure characteristics (At rated voltage)

[By double chamber method]

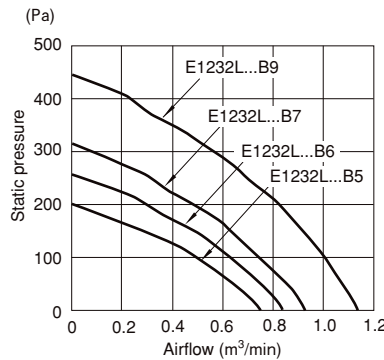

External dimensions in mm (inches)

● Lead wire type

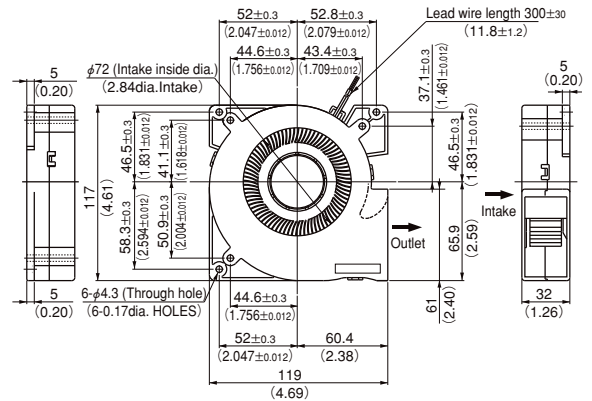

Lead wire spec. AWG24 UL1007 or UL3266
Color (+) Red
(-) Black

Wiring connection diagram

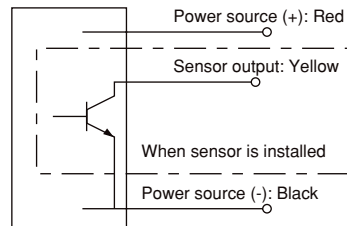

Super silent blower with sensor

| Rated Vol. | Model Code | | | |
|------------|-----------------|-----------------|-----------------|-----------------|
| 12 V | E1232L12B5AP-00 | E1232L12B6AP-00 | E1232L12B7AP-00 | E1232L12B9AP-00 |
| | E1232L12B5AS-00 | E1232L12B6AS-00 | E1232L12B7AS-00 | E1232L12B9AS-00 |
| 12 V | E1232L24B5AP-00 | E1232L24B6AP-00 | E1232L24B7AP-00 | E1232L24B9AP-00 |
| | E1232L24B5AS-00 | E1232L24B6AS-00 | E1232L24B7AS-00 | E1232L24B9AS-00 |

- NIDEC SERVO can meet many of your requirements for customization, such as special connectors, other sensors not listed above, variable speed specifications, and other modifications. Please contact NIDEC SERVO during your product planning and development stage.
- The listed products are registered in the following overseas standards files, UL/cUL: E48889, TUV: R50004410

Super Silent Blowers

E1331K



126 × 127 × 32

(5.0" × 5.0" × 1.3")

Max. airflow: 1.08 m³/min

Max. static pressure: 480 Pa

Mass: 250 g

Fan model code

E1331K12B5AP-00

E1331K12B5AS-00

E1331K12B5AZ-00

E1331K12B6AP-00

E1331K12B6AS-00

E1331K12B6AZ-00

E1331K12B7AZ-00

E1331K12B9AP-00

E1331K12B9AS-00

E1331K12B9AZ-00

E1331K24B5AZ-00

E1331K24B6AP-00

E1331K24B6AS-00

E1331K24B6AZ-00

E1331K24B7AP-00

E1331K24B7AS-00

E1331K24B9AP-00

E1331K24B9AS-00

E1331K24B9AZ-00

Standard specification

| Max. Airflow m ³ /min | Max. Static Pressure CFM | Max. Static Pressure Pa | Noise inH ₂ O | Noise dB | Speed min ⁻¹ | Voltage Spec. V | | Current mA | | Model Code | Operating Temp. Range °C |
|-------------------------------------|-----------------------------|----------------------------|-----------------------------|-------------|----------------------------|-----------------|-----------------|------------|----------|-----------------|-----------------------------|
| | | | | | | Rating | Operating Range | Rating | Starting | | |
| 1.08 | 38 | 480 | 1.93 | 54 | 3400 | 12 | 8.4-13.2 | 1100 | 1960 | E1331K12B9AZ-00 | -20 ~ +60 |
| | | | | | | 24 | 21-26.4 | 530 | 1980 | E1331K24B9AZ-00 | |
| 0.87 | 31 | 310 | 1.25 | 49 | 2700 | 12 | 6-13.2 | 690 | 1790 | E1331K12B7AZ-00 | -20 ~ +70 |
| | | | | | | 24 | 12-26.4 | 380 | 930 | E1331K24B7AZ-00 | |
| 0.79 | 28 | 250 | 1.01 | 47 | 2500 | 12 | 6-13.2 | 490 | 1400 | E1331K12B6AZ-00 | -20 ~ +70 |
| | | | | | | 24 | 12-26.4 | 280 | 710 | E1331K24B6AZ-00 | |
| 0.72 | 25 | 210 | 0.84 | 45 | 2200 | 12 | 6-13.2 | 440 | 1008 | E1331K12B5AZ-00 | -20 ~ +70 |
| | | | | | | 24 | 12-26.4 | 240 | 520 | E1331K24B5AZ-00 | |

- Figures in the table are average measured values. Please request the product delivery specification when preparing a purchase specification.
- The characteristics are the values at rated voltage (12 V or 24 V), and normal temperature and humidity.

General specification

| | |
|--------------------|---|
| Materials Used | Venturi: ABS and PBT synthetic resins Impeller: ABS and PBT synthetic resins Bearing: Both side shielded ball bearing |
| Motor | Brushless DC motor, Protection type: Current shut off by detecting lock state, automatically reset |
| Common Elec. Spec. | See pages G-11, G-12, G-13. |

Standard airflow and static pressure characteristics (At rated voltage)

[By double chamber method]

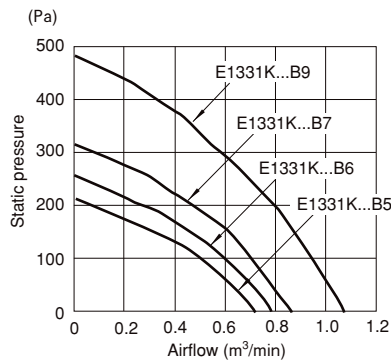

External dimensions in mm (inches)

● Lead wire type

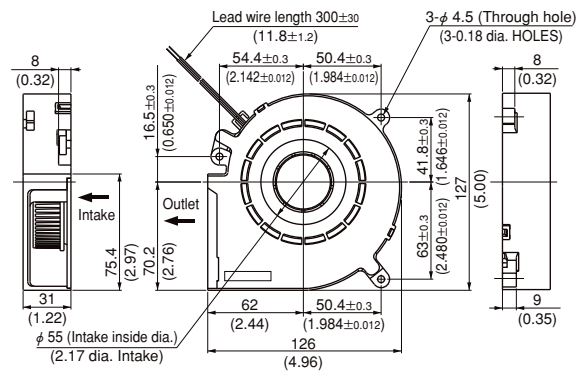

Lead wire spec. AWG24 UL1007 or UL3266
Color (+) Red
(-) Black

Wiring connection diagram

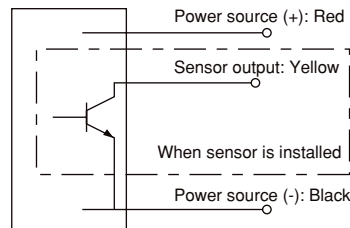

Super silent blower with sensor

| Rated Vol. | Model Code | | | |
|------------|-----------------|-----------------|-----------------|-----------------|
| 12 V | E1331K12B5AP-00 | E1331K12B6AP-00 | | E1331K12B9AP-00 |
| | E1331K12B5AS-00 | E1331K12B6AS-00 | | E1331K12B9AS-00 |
| 12 V | | E1331K24B6AP-00 | E1331K24B7AP-00 | E1331K24B9AP-00 |
| | | E1331K24B6AS-00 | E1331K24B7AS-00 | E1331K24B9AS-00 |

- NIDEC SERVO can meet many of your requirements for customization, such as special connectors, other sensors not listed above, variable speed specifications, and other modifications. Please contact NIDEC SERVO during your product planning and development stage.
- The listed products are registered in the following overseas standards files, UL/cUL: E48889, TUV: R50004410

Super Silent Blowers

E1540H

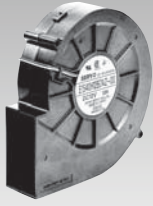

150×152×40
(5.9"×6.0"×1.6")
Max. airflow: 2.0 m³/min
Max. static pressure: 430 Pa
Mass: 380 g

Fan model code

E1540H12B5AS-00

E1540H12B5AZ-00

E1540H12B7AP-00

E1540H12B7AS-00

E1540H12B7AZ-00

E1540H24B5AS-00

E1540H24B5AZ-00

E1540H24B7AP-00

E1540H24B7AS-00

E1540H24B7AZ-00

Standard specification

| Max. Airflow | | Max. Static Pressure | | Noise dB | Speed min ⁻¹ | Input W | Voltage Spec. V | | Current mA | | Model Code | Operating Temp. Range °C |
|---------------------|-----|----------------------|--------------------|-------------|----------------------------|------------|-----------------|-----------------|------------|-----------------|-----------------|-----------------------------|
| m ³ /min | CFM | Pa | inH ₂ O | | | | Rating | Operating Range | Rating | Starting | | |
| 2.0 | 71 | 430 | 1.73 | 56 | 2700 | 19.4 | 12 | 8.4-13.8 | 1600 | 910 | E1540H12B7AZ-00 | -20 ~ +70 |
| | | | | | | 17.8 | 24 | 16.8-27.6 | 740 | 430 | E1540H24B7AZ-00 | |
| 1.65 | 58 | 270 | 1.09 | 51 | 2200 | 12 | 8.4-13.8 | 1100 | 1640 | E1540H12B5AZ-00 | | |
| | | | | | | 24 | 12-27.6 | 540 | 1450 | E1540H24B5AZ-00 | | |

- Figures in the table are average measured values. Please request the product delivery specification when preparing a purchase specification.
- The characteristics are the values at rated voltage (12 V or 24 V), and normal temperature and humidity.
- The life expectancy of E1540H-7 speed products at rated voltage and in continuous operation is 30,000 hours at 60°C. (40,000 hours for other products)

General specification

| | |
|--------------------|---|
| Materials Used | Venturi: ABS and PBT synthetic resins Impeller: ABS and PBT synthetic resins Bearing: Both side shielded ball bearing |
| Motor | Brushless DC motor, Protection type: Overcurrent detection and automatic resetting by current limiting |
| Common Elec. Spec. | See pages G-11, G-12, G-13. |
| Standard Carton | 16 to a carton of (450 x 380 x 220) mm, mass 7 kg |

Standard airflow and static pressure characteristics (At rated voltage)

[By double chamber method]

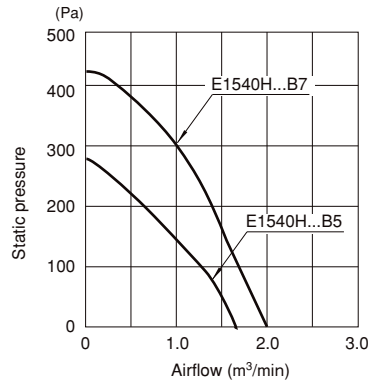

External dimensions in mm (inches)

● Lead wire type

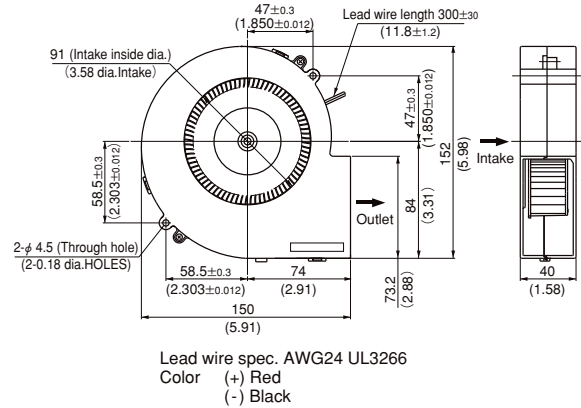

Wiring connection diagram

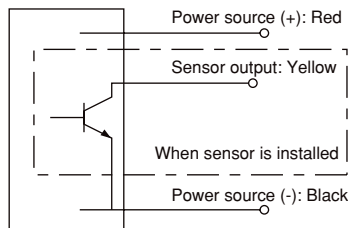

Super silent blower with sensor

| Rated Vol. | Model Code | |
|------------|-----------------|------------------------------------|
| 12 V | E1540H12B5AS-00 | E1540H12B7AS-00 E1540H12B7AP-00 |
| 24 V | E1540H24B5AS-00 | E1540H24B7AS-00 E1540H24B7AP-00 |

- NIDEC SERVO can meet many of your requirements for customization, such as special connectors, other sensors not listed above, variable speed specifications, and other modifications. Please contact NIDEC SERVO during your product planning and development stage.
- The listed products are registered in the following overseas standards files, UL/cUL: E48889, TUV: R50004410
- 3D data is also available at our web2-CAD site (www.cadenas.co.jp).

Super Silent Blowers

E2271Z

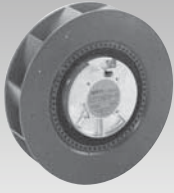

$\phi 220 \times 71$ ($\phi 8.7'' \times 2.8''$)
Max. airflow: 18.1 m³/min
Max. static pressure: 650 Pa
Mass: 1300 g

Features

- Large airflow, high static pressure backward blowers without housing.
- A low noise effect can be achieved by combining an inlet ring.

Fan model code

E2271Z24B5YP-00

E2271Z48B7AP-00

Standard specification

| Max. Airflow | | Max. Static Pressure | | Noise dB | Speed min ⁻¹ | Voltage Spec. V | | Current mA | | Model Code | Operating Temp. Range °C |
|---------------------|-----|----------------------|--------------------|----------|-------------------------|-----------------|-----------------|------------|----------|------------------------|--------------------------|
| m ³ /min | CFM | Pa | inH ₂ O | | | Rating | Operating Range | Rating | Starting | | |
| 18.1 | 639 | 650 | 2.61 | 71 | 3200 | 48 | 36-57 | 2100 | 4500 | E2271Z48B7AP-00 | -20 ~ +60 |
| 14.7 | 519 | 470 | 1.89 | 69 | 2650 | 24 | 21.0-26.4 | 2600 | 3800 | E2271Z24B5YP-00 | -20 ~ +40 |

- Figures in the table are average measured values. Please request the product delivery specification when preparing a purchase specification.
- The characteristics are the values at rated voltage (24V, or 48 V), and normal temperature and humidity.
- This product has limitations to ON/OFF functionality. For details, please reference the relevant diagrams in the specification.

General specification

| | |
|--------------------|---|
| Materials Used | Ventur: Aluminum alloy die castings Impeller: ABS and PBT synthetic resins Bearing: Both side shielded ball bearing |
| Motor | Brushless DC motor, Protection type: Overcurrent detection and automatic resetting by current limiting |
| Common Elec. Spec. | See pages G-11, G-12, G-13. |

Standard airflow and static pressure characteristics (At rated voltage)

[By double chamber method]
(Performance when an inlet ring is combined)

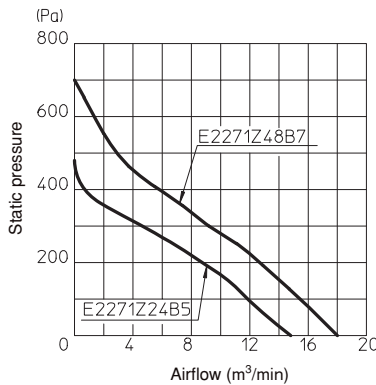

Wiring connection diagram

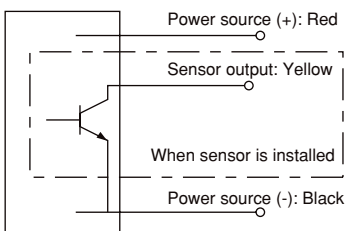

External dimensions in mm (inches)

● Lead wire type

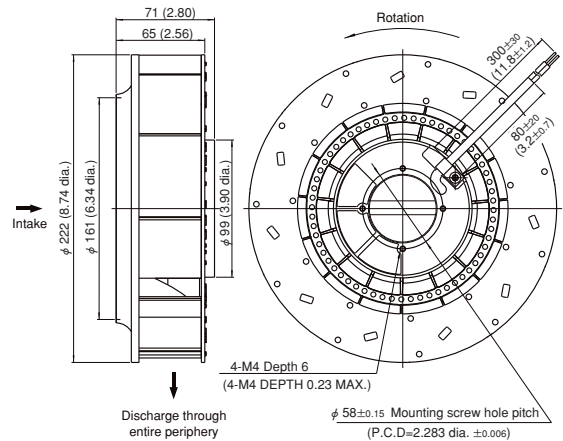

Lead wire spec. AWG24 UL3266
Color (+) Red
(-) Black
(sensor) Yellow

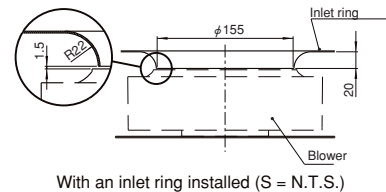

With an inlet ring installed (S = N.T.S.)

Options (sold separately)

- E2271 inlet ring

Products for variable-speed operation by PWM, voltage or resistance value commands can also be supplied with this model. (See pages G-51 and 52.)
Contact NIDEC SERVO for further information.

Super silent blower with sensor

| Rated Vol. | Model Code |
|------------|------------------------|
| 24 V | E2271Z24B5YP-00 |
| 48 V | E2271Z48B7AP-00 |

- This product features a large airflow and high static pressure without using a housing. A standard specification is ensured if installed complying with the foregoing bell mouth shape and its position.
- See page G-52 for detailed dimensions of the intake bell mouth.
- A bell mouth fitting accessory (product code E2271 Inlet Ring) is available as an option. (See page G-51.)
- NIDEC SERVO can meet many of your requirements for customization, such as special connectors, other sensors not listed above, variable speed specifications, and other modifications. Please contact NIDEC SERVO during your product planning and development stage.
- The listed products are registered in the following overseas standards files, UL/cUL: E48889, TUV: R9451586 (E2271Z48B7 only models.)

Fan model code

- D0925C12B8ZP-00
- D0925C24B8ZP-00
- D1238B48B7ZP-00
- D1751M24B4ZP-00
- D1751M24B5ZP-00
- D1751M24B6ZP-00
- D1751M24B7ZP-00
- D1751M24B8ZP300
- D1751M24B9ZP300
- D1751M48B4ZP-00
- D1751M48B5ZP-00
- D1751M48B6ZP-00
- D1751M48B7ZP-00
- D1751M48B8ZP-00
- D1751M48B9ZP-00
- D1751S24B4ZP-00
- D1751S24B5ZP-00
- D1751S24B6ZP-00
- D1751S24B6ZQ-00
- D1751S24B7ZP-00
- D1751S24B8ZP300
- D1751S24B9ZP300
- D1751S48B4ZP-00
- D1751S48B5ZP-00
- D1751S48B6ZP-00
- D1751S48B7ZP-00
- D1751S48B8ZP-00
- D1751S48B9ZP-00
- D1751S24B4ZR-13
- E1033H12B8ZS-00
- E1033H12BAZP-00
- E1033H24BAZS-00
- E1033H24BAZP-00
- E2271Z24B5YP-00
- E2271Z48B7ZP-00

Lineup of PWM variable-speed semi-standard products

● A PWM signal from the customer equipment is input to the control line (blue) of the fan motor for variable-speed operation of fans and blowers. (Input and noise can be reduced when the internal temperature of the customer equipment is low, such as during idling.)

- Sizes
Axial fans: □60 mm~□172 mm
Blower: □70 mm~φ220 mm

Characteristics for reference

(The characteristics are typical characteristics and their curves will differ, depending on the particular model)

● Standard values for PWM control signal - speed specification (at rated voltage, open, and normal temperature and humidity)

| | |
|--------------------|----------------|
| I _{out} | 1 mA MAX. |
| V _{out} | 5V. MAX. |
| V _{Losat} | 0.4 MAX. |
| Freq. | 500 Hz~5000 Hz |

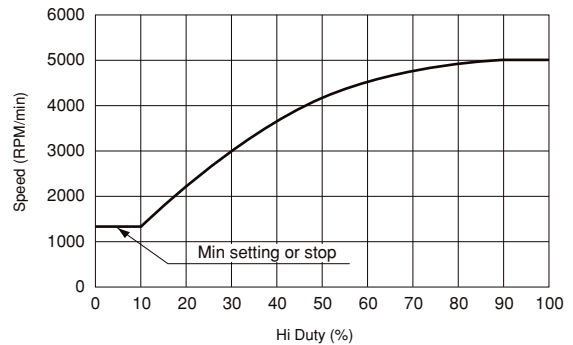
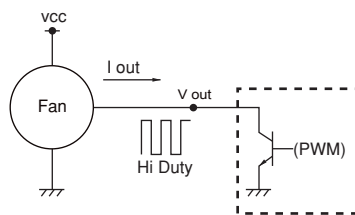

Semi-standard products (Products in regular production)

| Size | Model Code | Max. Airflow | | Max. Static Pressure | | Noise dB | Speed min ¹ | | Voltage Spec. V | | Operating Temp. Range °C |
|----------------------|-----------------|---------------------|------|----------------------|--------------------|----------|------------------------|------|-----------------|-----------------|--------------------------|
| | | m ³ /min | CFM | Pa | inH ₂ O | | Max. | Min. | Rating | Operating Range | |
| □92×25mm | D0925C12B8ZP-00 | 2 | 71 | 67 | 0.27 | 40 | 4450 | 1000 | 12 | 10.2-13.2 | -20 ~ 60°C |
| | D0925C24B8ZP-00 | | | | | | 4450 | 1750 | 24 | 21.6-26.4 | |
| □120×38mm | D1238B48B7ZP-00 | 4.4 | 155 | 170 | 0.68 | 54 | 4000 | 1250 | 48 | 40.8-55.2 | -20 ~ 70°C |
| | D1751M24B9ZP300 | 14.2 | 501 | 580 | 2.33 | 75 | 6800 | 3200 | 24 | 16-28 | |
| φ172×150×51mm | D1751M48B9ZP-00 | 14.2 | 501 | 580 | 2.33 | 75 | 6800 | 3200 | 48 | 36-60 | -20 ~ 70°C |
| | D1751M24B8ZP300 | 12.7 | 448 | 510 | 2.05 | 72 | 6100 | 2600 | 24 | 16-28 | |
| | D1751M48B8ZP-00 | 12.7 | 448 | 510 | 2.05 | 72 | 6100 | 2600 | 48 | 36-60 | |
| | D1751M24B7ZP-00 | 11.4 | 402 | 410 | 1.65 | 69 | 5400 | 1500 | 24 | 12-27.6 | |
| | D1751M48B7ZP-00 | 11.4 | 402 | 410 | 1.65 | 69 | 5400 | 1500 | 48 | 36-60 | |
| | D1751M24B6ZP-00 | 10.2 | 360 | 315 | 1.27 | 64 | 4800 | 1000 | 24 | 12-27.6 | |
| | D1751M48B6ZP-00 | 10.2 | 360 | 315 | 1.27 | 64 | 4800 | 1000 | 48 | 36-60 | |
| | D1751M24B5ZP-00 | 9 | 318 | 260 | 1.04 | 61 | 4200 | 1000 | 24 | 12-27.6 | |
| | D1751M48B5ZP-00 | 9 | 318 | 260 | 1.04 | 61 | 4200 | 1000 | 48 | 36-60 | |
| | D1751M24B4ZP-00 | 8 | 282 | 205 | 0.82 | 57 | 3800 | 1000 | 24 | 12-27.6 | |
| | D1751M48B4ZP-00 | 8 | 282 | 205 | 0.82 | 57 | 3800 | 1000 | 48 | 36-60 | |
| | φ172×51mm | D1751S24B9ZP300 | 14.2 | 501 | 640 | 2.57 | 68 | 6800 | 3200 | 24 | |
| D1751S48B9ZP-00 | | 14.2 | 501 | 640 | 2.57 | 68 | 6800 | 3200 | 48 | 36-60 | |
| D1751S24B8ZP300 | | 12.7 | 448 | 520 | 2.09 | 65 | 6100 | 2600 | 24 | 16-28 | |
| D1751S48B8ZP-00 | | 12.7 | 448 | 520 | 2.09 | 65 | 6100 | 2600 | 48 | 36-60 | |
| D1751S24B7ZP-00 | | 11.4 | 402 | 435 | 1.75 | 62 | 5400 | 1500 | 24 | 12-27.6 | |
| D1751S48B7ZP-00 | | 11.4 | 402 | 435 | 1.75 | 62 | 5400 | 1500 | 48 | 36-60 | |
| D1751S24B6ZP-00 | | 10.2 | 360 | 335 | 1.35 | 59 | 4800 | 1000 | 24 | 12-27.6 | |
| D1751S48B6ZP-00 | | 10.2 | 360 | 335 | 1.35 | 59 | 4800 | 1000 | 48 | 36-60 | |
| D1751S24B5ZP-00 | | 9 | 318 | 270 | 1.08 | 56 | 4200 | 1000 | 24 | 12-27.6 | |
| D1751S48B5ZP-00 | | 9 | 318 | 270 | 1.08 | 56 | 4200 | 1000 | 48 | 36-60 | |
| D1751S24B4ZP-00 | | 8 | 282 | 220 | 0.88 | 53.5 | 3800 | 1000 | 24 | 12-27.6 | |
| D1751S48B4ZP-00 | | 8 | 282 | 220 | 0.88 | 53.5 | 3800 | 1000 | 48 | 36-60 | |
| 97×95×33mm (Blowers) | D1751S24B4ZR-13 | 8 | 282 | 230 | 0.92 | 53.5 | 3800 | 1500 | 24 | 20.4-27.6 | -20 ~ 70°C |
| | E1033H12B8ZS-00 | 0.85 | 30 | 320 | 1.29 | 51 | 3450 | 1250 | 12 | 10.8-13.2 | |
| 97×95×33mm (Blowers) | E1033H12BAZP-00 | 1.14 | 40 | 500 | 2.01 | 58 | 4850 | 1800 | 24 | 21.6-26.4 | -20 ~ 60°C |
| | E1033H24BAZP-00 | | | | | | | | | | |
| | E1033H24BAZS-00 | | | | | | | | | | |
| φ220×71mm (Blowers) | E2271Z48B7ZP-00 | 18.1 | 639 | 600 | 2.41 | 74 | 3200 | 1000 | 48 | 36-57 | -20 ~ 60°C |
| | E2271Z24B5YP-00 | 14.7 | 519 | 470 | 1.89 | 66 | 2650 | 530 | 24 | 21.6-26.4 | |

※ The D1751S24B4ZR-13 is a FFU (Fan Filter Unit) product. Only this version allows for voltage designed speed variation

- Aside from the above models, please see also the high pressure, variable speed G series fans.
- The lineup of variable-speed fans and blowers will be expanded regularly. Visit the NIDEC SERVO Website for information on the latest lineup.
- Direct your inquiry to NIDEC SERVO for connector termination to lead wires, for sensor specifications other than those contained in the catalog and for variable speed specifications. (Products tailored to voltage command control and resistance value command control are also available)
- To ensure correct installation and smooth operation please obtain a drawing for approval or reference drawing from NIDEC SERVO Co.

Fully customized products

Fully customized products will be manufactured to optimally match your equipment for high volume needs. (more than 10,000 units/month) for home appliances such as refrigerators, air conditioners and washing machines and for industrial machinery and information communication equipment, including open showcases, power sources and computer-related equipment. Please contact NIDEC SERVO for more information.



Fully customized product example 1



Fully customized product example 2

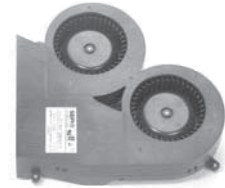

Fully customized product example 3

Semi-customized products

Semi-customized products, including the following, will be manufactured by combining a large variety of components available to NIDEC SERVO. Please contact NIDEC SERVO for more information.

- 1) For operation in a high-temperature atmosphere of 80 °C.
- 2) Long life products (60,000 hours or longer at 60 °C, 100,000 hours at 50 °C)
- 3) Energy saving products (30 % to 50 % less input compared with conventional products)
- 4) IP55 products (Outdoor installation and in a high-humidity environment)
- 5) Variable-speed products (PWM, voltage or resistance value command), dual-speed products
- 6) Fans for high static pressure regions (92 mm sq. x 38 mm thick, 120 mm sq. x 38 mm thick, 172 mm dia. x 51 mm thick and others)
- 7) Fans to prevent galvanic corrosion of ball bearings (ceramic ball specification)

Fan tray units

- Tray units fitted with a standard or semi-customized fans.
- Tray shape designed, manufactured and tailored to customer specifications.

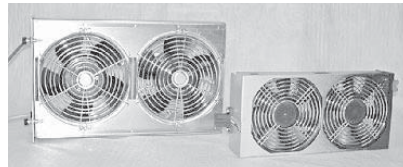

Fan tray unit example 1



Fan tray unit example 2

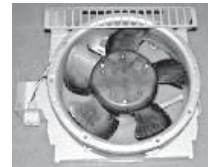

Fan unit example

AC Axial Fan
VE



□ 80 × 25 (□ 3.2" × 1.0")
 Max. airflow: 0.55 m³/min (50 Hz)
 0.65 m³/min (60 Hz)
 Max. static pressure:
 42 Pa (50 Hz) 60 Pa (60 Hz)
 Mass: 250 g

Fan model code

- VE115B5
- VE2B5
- VE47F5
- VE48F5
- VE50B5
- VE52B5
- VE55B5
- VE60B5
- VEJ47F5
- VEJ48F5
- VEJ55B5
- VEJ60B5

Standard specification

(Input and current are indicated on name plate)

| Max. Airflow | | Max. Static Pressure | | Noise | Speed | Rated Vol. | Freq. | Input | Current | Lock | Model Code | | | |
|---------------------|---------|----------------------|--------------------|---------|-------------------|-------------------|---------|--------|---------|------------|----------------|------|----------------|------|
| m ³ /min | CFM | Pa | inH ₂ O | dB | min ⁻¹ | V (±10%) | Hz | W | mA | Current mA | Lead Wire Type | Std* | Lead Wire Type | Std* |
| 0.55 / 0.65 | 19 / 23 | 42 / 60 | 0.17 / 0.24 | 30 / 35 | 2750 / 3300 | 100 | 50 / 60 | 11/9 | 130/110 | 130/110 | VE55B5 | U | VEJ55B5 | P |
| | | | | | | 200 | | 11/8.5 | 80/70 | 80/75 | VE60B5 | U | VEJ60B5 | P |
| | | | | | | 115 | | 11/9 | 130/100 | 170/130 | VE2B5 | U | | |
| | | | | | | 208-230 | | 11/10 | 70/60 | 75/65 | VE52B5 | U | | |
| | | | | | | 115 | | 11/9 | 140/110 | 140/110 | VE115B5 | UTV | | |
| 0.56 / 0.68 | 20 / 24 | 45 / 66 | 0.18 / 0.27 | 30 / 35 | 2750 / 3300 | 220/230 | | 9/8 | 70/60 | 75/65 | VE50B5 | UTV | | |
| 0.37 / 0.48 | 13 / 17 | 17 / 29 | 0.07 / 0.12 | 27 / 31 | 1800 / 2300 | 100-120 / 200-240 | 50 / 60 | 12/10 | 130/110 | 130/110 | VE47F5 | TV | VEJ47F5 | P |
| | | | | | | | | 12/10 | 70/60 | 70/60 | VE48F5 | TV | VEJ48F5 | P |

- Figures in the table are average measured values. Please request the product delivery specification when preparing a purchase specification.
- *The symbols in the standards column denote that they are registered in the following standards files, U: UL E48889, T: TUV R60229-60302, V: VDE 3019UG
- *Products conforming to the specifications of the Electrical Appliance and Material Safety Law (Japan) can be used in case the products are assembled in electric appliances used in Japan. (Products marked with the (PS)E mark)

General specification

| | |
|-----------------------|---|
| Materials Used | Venturi: Aluminum alloy die casting Propeller: Glass fiber reinforced polycarbonate resin Bearing: Double - sided shielded ball bearing |
| Motor | Shaded pole induction motor Protection type: Impedance protection |
| Common Elec. Spec. | See pages G-12. |
| Usage Range | Rated voltage ±10 % |
| Operating Temp. Range | -20 °C ~ +60 °C (-20 °C ~ +55 °C in TÜV standard -20 °C ~ +40 °C in VDE standard) |
| Standard Carton | 40 to a carton of (450 x 380 x 160) mm, mass 11 kg |

Standard airflow and static pressure characteristics (At rated voltage)

VE□□B5

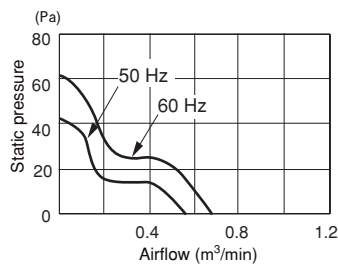

VE□□F5

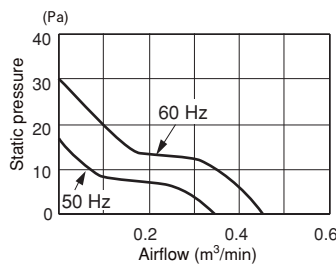

External dimensions in mm (inches)

● Lead wire type

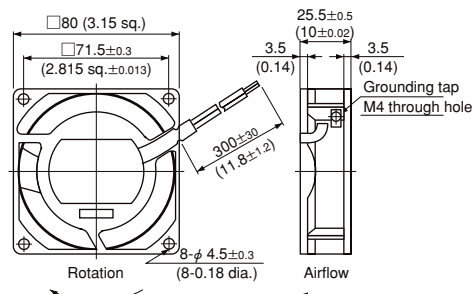

Lead wire specification
 VEJ series: Heat resistant PVC 0.75 mm² (30 conductors, 0.18 dia.)
 VE series: AWG22 UL1015

Options (sold separately)

- Guard: F80UL guard
- Filter: F80 filter

Mounting hole dimensions in mm (inches)
[Recommendation]

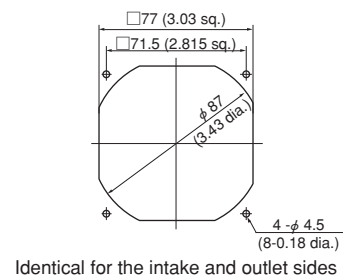

Identical for the intake and outlet sides

AC Axial Fan
WE



□ 92 × 25 (□ 3.6" × 1.0")
 Max. airflow: 0.85 m³/min (50 Hz)
 1.0 m³/min (60 Hz)
 Max. static pressure:
 49 Pa (50 Hz) 67 Pa (60 Hz)
 Mass: 290 g

Fan model code

- WE115B5
- WE2B3
- WE2B5
- WE47F3
- WE47F5
- WE48F3
- WE48F5
- WE50B5
- WE52B3
- WE52B5
- WE55B3
- WE55B5
- WE60B3
- WE60B5
- WEJ55B5
- WEJ60B5

Standard specification

(Input and current are indicated on name plate)

| Max. Airflow | | Max. Static Pressure | | Noise dB | Speed min ⁻¹ | Rated Vol. V (±10%) | Freq. Hz | Input W | Current mA | Lock Current mA | Model Code | | | |
|---------------------|-----------|----------------------|--------------------|-------------|----------------------------|------------------------|-------------|------------|---------------|--------------------|----------------|------|---------------|------|
| m ³ /min | CFM | Pa | inH ₂ O | | | | | | | | Lead Wire Type | Std* | Terminal Type | Std* |
| 0.85/ 1.0 | 30/ 35 | 49/ 67 | 0.20/ 0.27 | 35/ 40 | 2700/ 3200 | 100 | 50/ 60 | 11/9 | 130/110 | 140/130 | WE55B5 | UC | WE55B3 | UCP |
| | | | | | | | | 9/7.5 | 130/110 | 140/130 | WEJ55B5 | P | | |
| | | | | | | | | 12/10 | 70/60 | 80/75 | WE60B5 | UC | WE60B3 | UCP |
| | | | | | | | | 12/10 | 70/60 | 80/75 | WEJ60B5 | P | | |
| | | | | | | | | 11/9 | 120/100 | 140/120 | WE2B5 | UC | WE2B3 | UCP |
| | | | | | | | | 11/10 | 70/60 | 75/70 | WE52B5 | UC | WE52B3 | UCP |
| 0.85/ 1.0 | 30/ 35 | 52/ 74 | 0.21/ 0.30 | 35/ 40 | 2700/ 3200 | 220/230 | 50/ 60 | 11/10 | 80/70 | 90/80 | WE50B5 | UTV | | |
| | | | | | | | | | | | | | | |
| 0.55/ 0.68 | 19/ 24 | 19/ 27 | 0.07/ 0.11 | 25/ 30 | 1750/ 1750 | 100-120/ 200-240 | 50/ 60 | 12/10 | 120/110 | 120/110 | WE47F5 | UTV | WE47F3 | UP |
| | | | | | | | | 12/10 | 80/60 | 80/60 | WE48F5 | | WE48F3 | UP |

- Figures in the table are average measured values. Please request the product delivery specification when preparing a purchase specification.
- *The symbols in the standards column denote that they are registered in the following standards files, U: UL E48889, T: TUV R60229-60302, V: VDE 3019UG
- *Products conforming to the specifications of the Electrical Appliance and Material Safety Law (Japan) can be used in case the products are assembled in electric appliances used in Japan. (Products marked with the (PS)E mark)

General specification

| | |
|-----------------------|---|
| Materials Used | Venturi: Aluminum alloy die casting Propeller: Glass fiber reinforced polycarbonate resin Bearing: Double - sided shielded ball bearing |
| Motor | Shaded pole induction motor Protection type: Impedance protection |
| Common Elec. Spec. | See pages G-12. |
| Usage Range | Rated voltage ±10% |
| Operating Temp. Range | -20 °C ~ +60 °C (-20 °C ~ +55 °C in TUV standard -20 °C ~ +40 °C in VDE standard) |
| Standard Carton | 40 to a carton of (480 x 380 x 160) mm, mass 12 kg |

Standard airflow and static pressure characteristics (At rated voltage)

WE□□B□

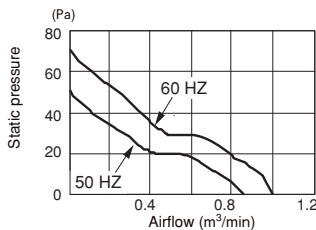

WE□□F□

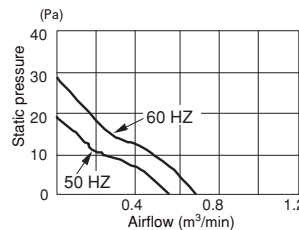

External dimensions in mm (inches)

● Lead wire type (WE□□□5)

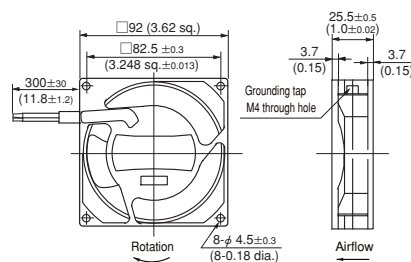

● Terminal type [2 terminals: with grounding tap] (WE□□□3)

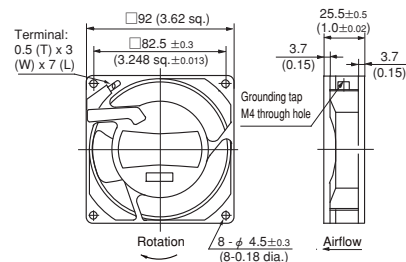

Lead wire specification
 WEJ series: Heat resistant PVC 0.75 mm² (30 conductors, 0.18 dia.)
 WE series: AWG22 UL1015

Mounting hole dimensions in mm (inches)
[Recommendation]

Options (sold separately)

- Guard: F92UL guard
- Filter: F92 filter
- Power code: T2P1 code, D2P1 code, UL2P1 code

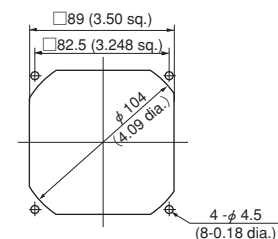

Identical for the intake and outlet sides

AC Axial Fan
KA



□92 × 38 (□3.6" × 1.5")
 Max. airflow: 1.1 m³/min (50 Hz)
 1.3 m³/min (60 Hz)
 Max. static pressure:
 62 Pa (50 Hz) 80 Pa (60 Hz)
 Mass: 450 g

Fan model code

- KA2B3
- KA2B4
- KA47D3
- KA47D5
- KA52B3
- KA52B5
- KA55B3
- KA55B4
- KA60B3
- KA60B5
- KAJ55B4
- KAJ60B5

Standard specification

(Input and current are indicated on name plate)

| Max. Airflow | | Max. Static Pressure | | Noise dB | Speed min ⁻¹ | Rated Vol. V (±10%) | Freq. Hz | Input W | Current mA | Lock Current mA | Model Code | | | |
|---------------------|-----------|----------------------|--------------------|-------------|----------------------------|------------------------|-------------|------------|---------------|--------------------|----------------|------|---------------|------|
| m ³ /min | CFM | Pa | inH ₂ O | | | | | | | | Lead Wire Type | Std* | Terminal Type | Std* |
| 1.1/ 1.3 | 39/ 46 | 62/ 80 | 0.25/ 0.32 | 31/ 38 | 2850/ 3300 | 100 | 50/ 60 | 8.5/8 | 200/160 | 200/160 | KA55B4 | U | KA55B3 | UP |
| | | | | | | 100 | | 7/6 | 200/160 | 200/160 | KAJ55B4 | P | | |
| | | | | | | 200 | | 8.5/8 | 100/70 | 100/75 | KA60B5 | U | KA60B3 | UP |
| | | | | | | 200 | | 7/6 | 100/70 | 100/75 | KAJ60B5 | P | | |
| | | | | | | 115 | | 8.5/8 | 180/150 | 180/150 | KA2B4 | U | KA2B3 | UP |
| 0.8/ 0.9 | 28/ 32 | 29/ 36 | 0.12/ 0.15 | 26/ 28 | 2250/ 2650 | 100-120 | 50/ 60 | 8/7 | 180/150 | 180/150 | KA47D5 | U | KA47D3 | UP |
| | | | | | | 208-230 | | 8.5/8 | 90/70 | 90/70 | KA52B5 | U | KA52B3 | UP |

- Figures in the table are average measured values. Please request the product delivery specification when preparing a purchase specification.
- *The symbols in the standards column denote that they are registered in the following standards files, U: UL E48889
- *Products conforming to the specifications of the Electrical Appliance and Material Safety Law (Japan) can be used in case the products are assembled in electric appliances used in Japan. (Products marked with the (PS)E mark)

General specification

| | |
|-----------------------|--|
| Materials Used | Venturi: Aluminum alloy die casting Propeller: PBT resin Bearing: Double - sided shielded ball bearing |
| Motor | Shaded pole induction motor Protection type: Impedance protection |
| Common Elec. Spec. | See page G-12. |
| Usage Range | Rated voltage ±10 % |
| Operating Temp. Range | -20 °C ~ +60 °C |
| Standard Carton | 20 to a carton of (450 x 380 x 150) mm, mass 10 kg |

Standard airflow and static pressure characteristics (At rated voltage)

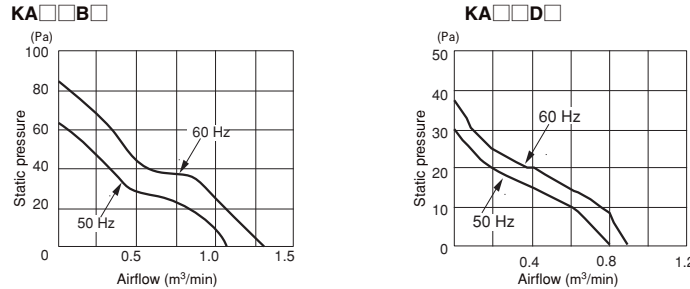

External dimensions in mm (inches)

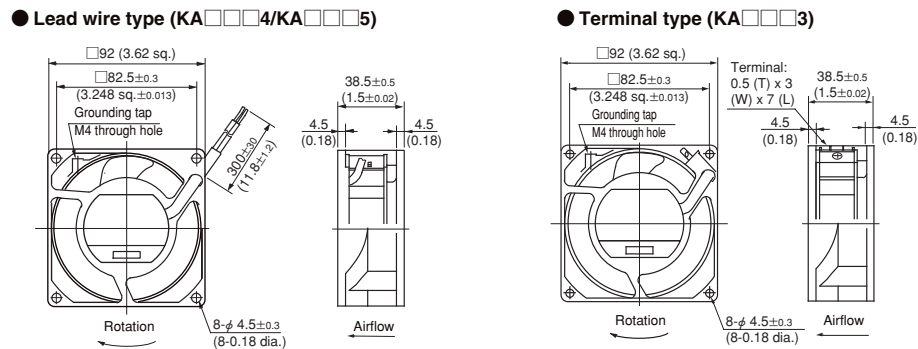

Lead wire specification
 KAJ series: Heat resistant PVC 0.75 mm² (30 conductors, 0.18 dia.)
 KA series: AWG22 UL1015

Mounting hole dimensions in mm (inches)
[Recommendation]

Options (sold separately)

- Guard: F92UL guard
- Filter: F92 filter
- Power code: T2P1 code, D2P1 code, UL2P1 code

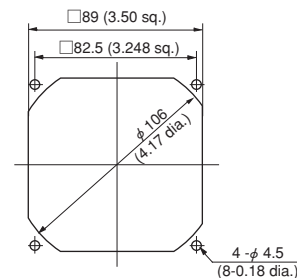

Identical for the intake and outlet sides

AC Axial Fan
CU



□ 120 × 25 (□ 4.7" × 1.0")

Max. airflow: 1.9 m³/min (50 Hz)
2.2 m³/min (60 Hz)

Max. static pressure:
53 Pa (50 Hz) 56 Pa (60 Hz)
Mass: 360 g

Fan model code

CU115B5

CU2B3

CU2B5

CU47F3

CU47F5

CU48F3

CU48F5

CU50B5

CU52B3

CU52B5

CU55B3

CU55B5

CU60B3

CU60B5

CUJ47F5

CUJ55B5

CUJ60B5

Standard specification

(Input and current are indicated on name plate)

| Max. Airflow m ³ /min | Max. Static Pressure Pa | Noise dB | Speed min ⁻¹ | Rated Vol. V (±10%) | Freq. Hz | Input W | Current mA | Lock Current mA | Model Code | | | | |
|-------------------------------------|----------------------------|-------------|----------------------------|------------------------|---------------|--|---------------|--------------------|----------------|---------|---------------|--------|-----|
| | | | | | | | | | Lead Wire Type | Std* | Terminal Type | Std* | |
| 1.9/ 2.2 | 67/ 78 | 53/ 56 | 0.21/ 0.23 | 40/ 45 | 2550/ 3000 | 100 | 16/14.5 | 190/140 | 200/170 | CU55B5 | UC | CU55B3 | UCP |
| | | | | | | | | | | CUJ55B5 | P | | |
| | | | | | | | | | | CU60B5 | UC | | |
| | | | | | | | | | | CUJ60B5 | P | | |
| | | | | | | | | | | CU60B3 | UC | CU60B3 | UCP |
| | | | | | | | | | | CU2B5 | UC | CU2B3 | UCP |
| | | | | | | | | | | CU52B5 | UC | | |
| | | | | | | | | | | CU52B3 | UC | | |
| | | | | | | | | | | CU115B5 | UTV | | |
| | | | | | | | | | | CU50B5 | UTV | | |
| 1.92/ 2.26 | 68/ 80 | 58/ 65 | 0.23/ 0.26 | 40/ 45 | 2550/ 3000 | 220/230 | 14/13 | 90/70 | 100/80 | CU50B5 | UTV | | |
| | | | | | | | | | | | | | |
| | | | | | | | | | | | | | |
| | | | | | | | | | | | | | |
| 1.2/ 1.4 | 42/ 49 | 19/ 24 | 0.07/ 0.10 | 27/ 34 | 1500/ 1900 | 100-120 100-120 200-240 200-240 | 14/11 | 170/130 | 170/130 | CU47F5 | UCT | CU47F3 | UCP |
| | | | | | | | | | | CUJ47F5 | P | | |
| | | | | | | | | | | CU48F5 | UCT | | |
| | | | | | | | | | | | | CU48F3 | UCP |
| | | | | | | | 14/10.5 | 80/60 | 80/60 | | | | |

- Figures in the table are average measured values. Please request the product delivery specification when preparing a purchase specification.
- *The symbols in the standards column denote that they are registered in the following standards files, U: UL E48889, C: CSA LR49399, LR108118, T: TUV R60229-60302, V: VDE 3019UG
- *Products conforming to the specifications of the Electrical Appliance and Material Safety Law (Japan) can be used in case the products are assembled in electric appliances used in Japan. (Products marked with the (PS)E mark)

General specification

| | |
|-----------------------|---|
| Materials Used | Venturi: Aluminum alloy die casting Propeller: Glass fiber reinforced polycarbonate resin Bearing: Double - sided shielded ball bearing |
| Motor | Shaded pole induction motor Protection type: Impedance protection |
| Common Elec. Spec. | See page G-12. |
| Usage Range | Rated voltage ±10 % |
| Operating Temp. Range | -20 °C ~ +60 °C (-20 °C ~ +55 °C in TUV standard) (-20 °C ~ +40 °C in VDE standard) |
| Standard Carton | 30 to a carton of (450 x 380 x 160) mm, mass 12 kg |

Standard airflow and static pressure characteristics (At rated voltage)

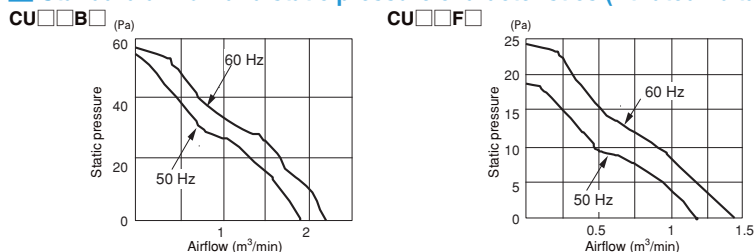

External dimensions in mm (inches)

Lead wire type (CU□□□5)

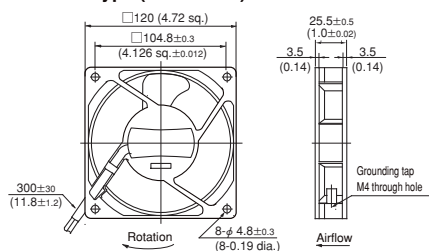

Lead wire specification
CUJ series: Heat resistant PVC 0.75 mm² (30 conductors, 0.18 dia.)
CU series: AWG22 UL1015

Terminal type

[2 terminals: with grounding tap](CU□□□3)

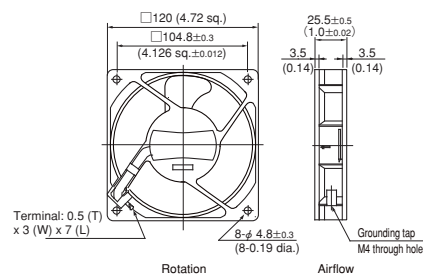

Mounting hole dimensions in mm (inches)
[Recommendation]

Options (sold separately)

- Guard: F120UL guard
- Filter: F120 filter
- Power code: T2P1 code, D2P1 code, UL2P1 code

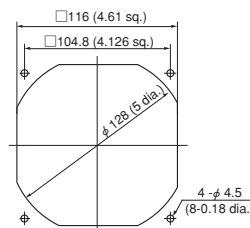

Identical for the intake and outlet sides

AC Axial Fan
CN



□ 120 × 38 (□ 4.7" × 1.5")
 Max. airflow: 2.6 m³/min (50 Hz)
 3.0 m³/min (60 Hz)
 Max. static pressure:
 83 Pa (50 Hz) 88 Pa (60 Hz)
 Mass: 500 g

Fan model code

- CN115B5
- CN2B2
- CN2B3
- CN2B5
- CN47D2
- CN47D3
- CN47D5
- CN48B3
- CN48D3
- CN48D5
- CN50B5
- CN52B2
- CN52B3
- CN52B5
- CN55B2
- CN55B3
- CN55B5
- CN60B2
- CN60B3
- CN60B5
- CNJ47D5
- CNJ48D5
- CNJ55B5
- CNJ60B5

Standard specification

(Input and current are indicated on name plate)

| Max. Airflow | | Max. Static Pressure | | Noise | Speed | Rated Vol. | Freq. | Input | Current | Lock | Model Code | | | |
|---------------------|------------|----------------------|--------------------|-----------|-------------------|------------|-----------|---------|---------|------------|----------------|---------|-------------------|---------------------|
| m ³ /min | CFM | Pa | inH ₂ O | dB | min ⁻¹ | V (±10%) | Hz | W | mA | Current mA | Lead Wire Type | Std* | Terminal Type (*) | Std* |
| 2.6/ 3.0 | 92/ 106 | 83/ 88 | 0.33/ 0.35 | 44/ 48 | 2800/ 3200 | 100 | 50/ 60 | 14/12 | 200/180 | 300/270 | CN55B5 | UC | CN55B3, CN55B2 | UCP |
| | | | | | | | | 15/13 | 200/180 | 300/270 | CNJ55B5 | P | | |
| | | | | | | | | 14/12 | 110/90 | 155/135 | CN60B5 | UC | CN60B3, CN60B2 | UCP ^{note} |
| | | | | | | | | 15/13 | 110/90 | 155/135 | CNJ60B5 | P | | |
| | | | | | | | | 16/13 | 200/170 | 300/260 | CN2B5 | UC | CN2B3, CN2B2 | UCP |
| | | | | | | | | 14/13 | 110/90 | 160/140 | CN52B5 | UC | CN52B3, CN52B2 | UCP ^{note} |
| 2.4/ 2.8 | 85/ 99 | 74/ 84 | 0.30/ 0.34 | 43/ 47 | 2700/ 3150 | 115 | 50/ 60 | 11/10 | 150/130 | 210/180 | CN115B5 | UCT | | |
| | | | | | | | | 13/13 | 100/90 | 130/120 | CN50B5 | UCT | | |
| | | | | | | | | 100-120 | 9/8.5 | 110/100 | 110/100 | CN47D5 | UCT | CN47D3, CN47D2 |
| 1.6/ 1.6 | 56/ 56 | 23/ 24 | 0.09/ 0.10 | 33/ 35 | 1700/ 1800 | 115 | 50/ 60 | 8.5/8 | 110/100 | 110/100 | CNJ47D5 | P | | |
| | | | | | | | | 9/8.5 | 60/50 | 60/50 | CN48D5 | UCT | CN48D3 | UCP |
| | | | | | | | | 200-240 | 9/8.5 | 60/50 | 60/50 | CNJ48D5 | P | |

- Figures in the table are average measured values. Please request the product delivery specification when preparing a purchase specification. (note) □: 2 terminals, □: 3 terminals
- *The symbols in the standards column denote that they are registered in the following standards files, U: UL E48889, C: CSA LR49399, LR108118 T: TÜV R60229-60302
- *Products conforming to the specifications of the Electrical Appliance and Material Safety Law (Japan) can be used in case the products are assembled in electric appliances used in Japan. (Products marked with the (PS)E mark)
- (Note) Since CN60B2, and CN52B2, do not have a ground terminal, they are not products conforming to the specifications of the Electrical Appliance and Material Safety Law (Japan)

General specification

| | |
|-----------------------|---|
| Materials Used | Venturi: Aluminum alloy die casting Propeller: Glass fiber reinforced polycarbonate resin Bearing: Double - sided shielded ball bearing |
| Motor | Shaded pole induction motor Protection type: Impedance protection |
| Common Elec. Spec. | See page G-12. |
| Usage Range | Rated voltage ±10 % |
| Operating Temp. Range | -20 °C ~ +60 °C (-20 °C ~ +55 °C in TÜV standard) |
| Standard Carton | 20 to a carton of (450 x 380 x 160) mm, mass 11 kg |

Standard airflow and static pressure characteristics (At rated voltage)

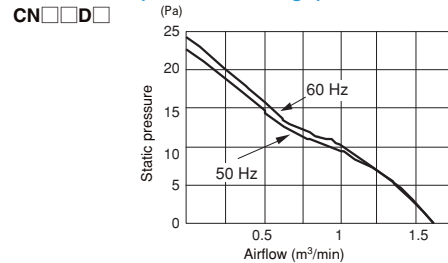
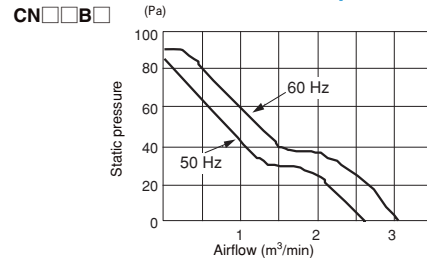

External dimensions in mm (inches)

Lead wire type (CN□□□□5)

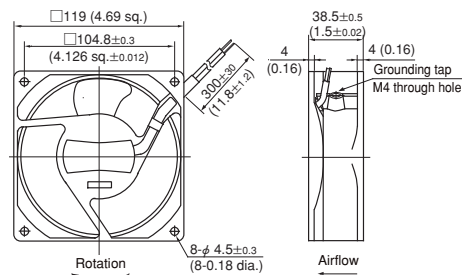

Lead wire specification
 CNJ series: Heat resistant PVC 0.75 mm² (30 conductors, 0.18 dia.)
 CN series: AWG22 UL1015

Terminal type

[2 terminals: without grounding tap] (CN□□□□2)
 [3 terminals: with grounding tap] (CN□□□□3)

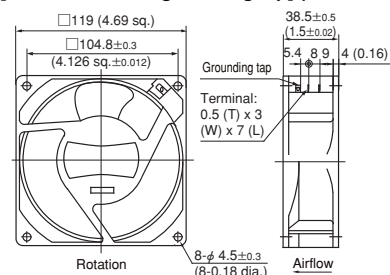

(Note) There is no grounding tap for CN series terminal type.

Mounting hole dimensions in mm (inches)
[Recommendation]

Options (sold separately)

- Guard: F120UL guard
- Filter: F120 filter
- Power code: T2P1 code, D2P1 code, UL2P1 code (for 2 terminals)
D3P1 code, UL3P1 code (for 3 terminals)

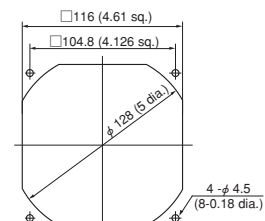

Identical for the intake and outlet sides

AC Axial Fan

MA



$\phi 172 \times 150 \times 51$
($\phi 6.8'' \times 6.0'' \times 2.0$)

Max. airflow: 5.5 m³/min (50 Hz)

6.5 m³/min (60 Hz)

Max. static pressure:

152 Pa (50 Hz) 186 Pa (60 Hz)

Mass: 950 g

Fan model code

MA2B3

MA47B3

MA48B3

MA55B3

MA60B3

MA77B3

Standard specification

(Input and current are indicated on name plate)

| Max. Airflow m ³ /min | Max. Static Pressure CFM | Max. Static Pressure Pa | Noise inH ₂ O | Noise dB | Speed min ⁻¹ | Rated Vol. V (±10%) | Freq. Hz | Input W | Current mA | Lock Current mA | Model Code | | |
|-------------------------------------|-----------------------------|----------------------------|-----------------------------|-------------|----------------------------|------------------------|-------------|---------------------|---------------|--------------------|---------------|-----------|-----|
| | | | | | | | | | | | Terminal Type | Standard* | |
| 5.5/ 6.5 | 194/ 229 | 152/ 186 | 0.61/ 0.75 | 50/ 55 | 2850/ 3400 | 100 | 50/ 60 | 32/28 | 400/310 | 620/600 | MA55B3 | UCP | |
| | | | | | | | | 29/28 | 270/250 | 470/460 | MA2B3 | UCP | |
| | | | | | | | | 200 | 200/150 | 300/300 | MA60B3 | UCP | |
| | | | | | | | | 220-240/ 208-230 | 33/30 | 150/130 | 250/240 | MA77B3 | UCP |
| | | | | | | | | 100-120 | 33/32 | 300/270 | 440/430 | MA47B3 | UCP |
| | | | | | | | | 200-240 | 33/32 | 150/140 | 240/240 | MA48B3 | UCP |

● Figures in the table are average measured values. Please request the product delivery specification when preparing a purchase specification.

● *The symbols in the standards column denote that they are registered in the following standards files, U: UL E48889, C: CSA LR49399

● *Products conforming to the specifications of the Electrical Appliance and Material Safety Law (Japan) can be used in case the products are assembled in electric appliances used in Japan. (Products marked with the (PS)E mark)

General specification

| | |
|-----------------------|---|
| Material used | Venturi: Aluminum alloy die casting Propeller: ABS and PBT synthetic resins Capacitor cover: Glass fiber reinforced polycarbonate resin Capacitor: MF capacitor Bearing: Double - sided shielded ball bearing |
| Motor | Capacitor phase advancing type induction motor Protection type: Thermal protection |
| Common Elec. Spec. | See page G-12. |
| Usage Range | Rated voltage ±10% |
| Operating Temp. Range | -20 °C ~ +60 °C |
| Standard Carton | 12 to a carton of (380 x 370 x 190) mm, mass 12.0 kg |

Standard airflow and static pressure characteristics (At rated voltage)

MA□B3

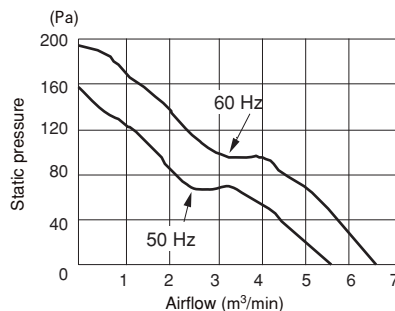

External dimensions in mm (inches)

● Terminal type

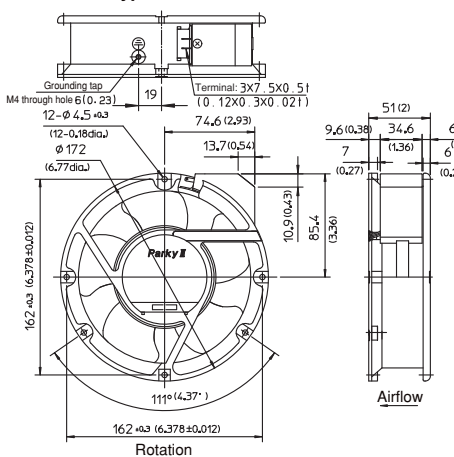

Options (sold separately)

- Guard: GUARD 172
- Power code: T2P1 code, D2P1 code, UL2P1 code

Mounting hole dimensions in mm (inches)
[Recommendation]

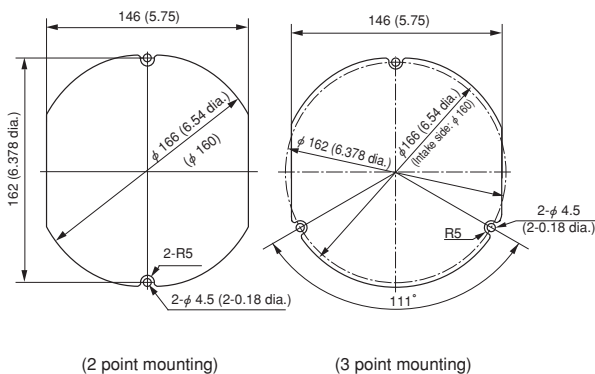

AC Axial Fan
PA



$\phi 172 \times 51$ ($\phi 6.8" \times 2.0"$)
 Max. airflow: 5.5 m³/min (50 Hz)
 6.5 m³/min (60 Hz)
 Max. static pressure:
 152 Pa (50 Hz) 186 Pa (60 Hz)
 Mass: 950 g

Fan model code

PA2B3M2

PA47B3M2

PA48B3M2

PA55B3M2

PA55H3M2

PA60B3M2

PA77B3M2

Standard specification

(Input and current are indicated on name plate)

| Max. Airflow | | Max. Static Pressure | | Noise dB | Speed min ⁻¹ | Rated Vol. V ($\pm 10\%$) | Freq. Hz | Input W | Current mA | Lock Current mA | Model Code | |
|---------------------|-------------|----------------------|--------------------|-------------|----------------------------|--------------------------------|-------------|------------|---------------|--------------------|---------------|-----------|
| m ³ /min | CFM | Pa | inH ₂ O | | | | | | | | Terminal Type | Standard* |
| 5.5/ 6.5 | 194/ 229 | 152/ 186 | 0.61/ 0.75 | 46/ 50 | 2850/ 3400 | 100 | 50/ 60 | 32/28 | 400/310 | 620/600 | PA55B3 | UCP |
| | | | | | | 115 | | 29/28 | 270/250 | 470/460 | PA2B3 | UCP |
| | | | | | | 200 | | 32/28 | 200/150 | 300/300 | PA60B3 | UCP |
| | | | | | | 220-240/ 208-230 | | 33/30 | 150/130 | 250/240 | PA77B3 | UCP |
| | | | | | | 100-120 | | 33/32 | 300/270 | 440/430 | PA47B3 | UCP |
| | | | | | | 200-240 | | 33/32 | 150/140 | 240/240 | PA48B3 | UCP |
| 4.7/4.7 | 166/166 | 90/75 | 0.36/0.30 | 44/44 | 2500/2500 | 100 | 17/19 | 180/200 | | PA55H3 | UP | |

- Figures in the table are average measured values. Please request the product delivery specification when preparing a purchase specification.
- *The symbols in the standards column denote that they are registered in the following standards files. U: UL E48889, C: CSA LR49399
- *Products conforming to the specifications of the Electrical Appliance and Material Safety Law (Japan) can be used in case the products are assembled in electric appliances used in Japan. (Products marked with the (PSE)E mark)

General specification

| | |
|-----------------------|---|
| Material Used | Venturi: Aluminum alloy die casting Propeller: ABS and PBT synthetic resins Capacitor cover: Glass fiber reinforced polycarbonate resin Capacitor: MF capacitor Bearing: Double - sided shielded ball bearing |
| Motor | Capacitor phase advancing type induction motor Protection type: Thermal protection |
| Common Elec. Spec. | See page G-12. |
| Usage Range | Rated voltage $\pm 10\%$ |
| Operating Temp. Range | -20 °C ~ +60 °C |
| Standard Carton | 12 to a carton of (420 x 410 x 220) mm, mass 12.5 kg |

Standard airflow and static pressure characteristics (At rated voltage)

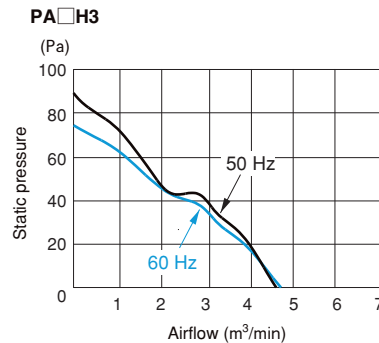
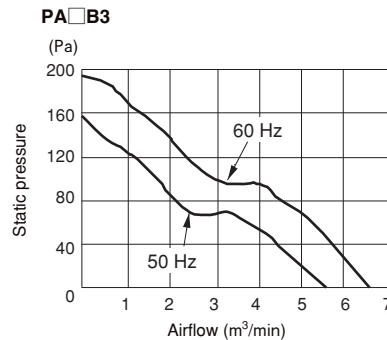

External dimensions in mm (inches)

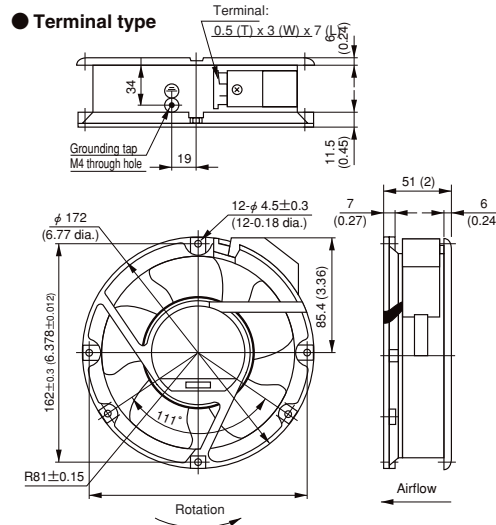

Options (sold separately)

- Guard: GUARD 172
- Power code: T2P1 code, D2P1 code, UL2P1 code

Mounting hole dimensions in mm (inches)
[Recommendation]

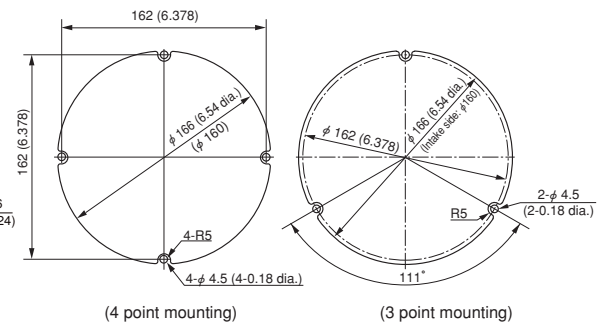

F60P Guard (Mass 4 g)

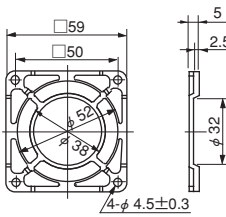

Material: Polycarbonate (black)
UL94V-2

F60UL Guard (Mass 12 g)

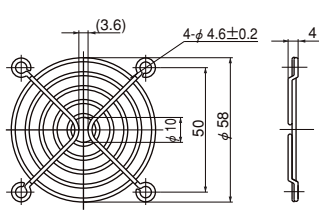

Material: Mild steel wire 1.6 dia.
Surface treatment:
Nickel chromium plating

F80UL Guard (Mass 14 g)

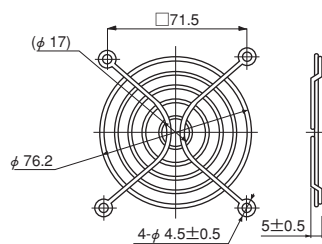

Material: Mild steel wire 1.6 dia.
Surface treatment:
Nickel chromium plating

F92UL Guard (Mass 16 g)

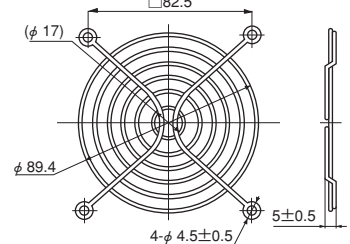

Material: Mild steel wire 1.6 dia.
Surface treatment:
Nickel chromium plating

F120UL Guard (Mass 29 g)

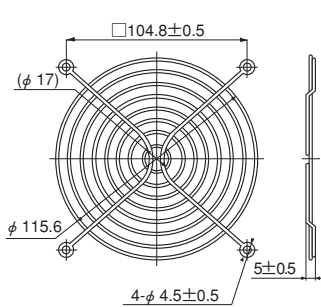

Material: Mild steel wire 1.6 dia.
Surface treatment:
Nickel chromium plating

F127UL Guard

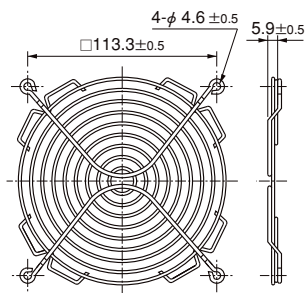

Material: Mild steel wire 1.6 dia.
Surface treatment:
Nickel chromium plating

GUARD 172

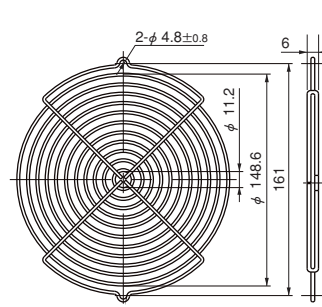

Material: Mild steel wire 2 dia.
Surface treatment:
Nickel chromium plating

F180UL Guard

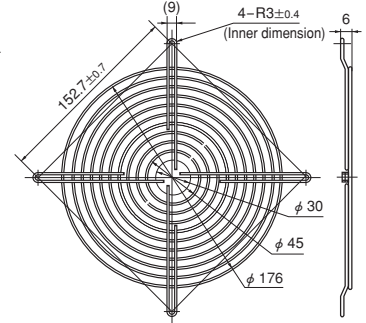

Material: Mild steel wire 1.6 dia.
Surface treatment:
Nickel chromium plating

F200UL Guard (Mass 82 g)

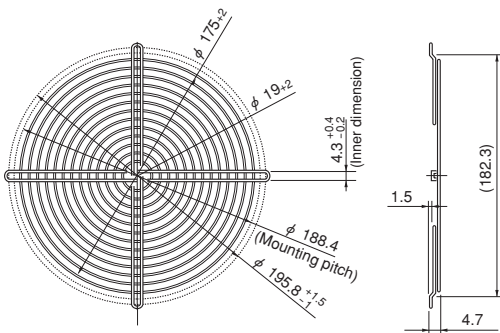

Material: Mild steel wire 1.6 dia.
Surface treatment:
Nickel chromium plating

SCU Guard (Mass 50 g)

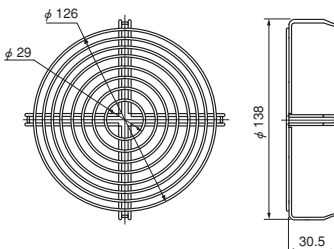

Material: Mild steel wire 1.6 dia.
Surface treatment:
Nickel chromium plating

SCN Guard (Mass 55 g)

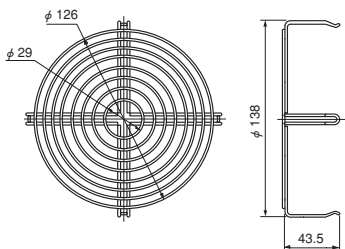

Material: Mild steel wire 1.6 dia.
Surface treatment:
Nickel chromium plating

• Guard special for intake side of SCUD (metal venturi) fans.

• Guard special for intake side of SCND (metal venturi) fans.

List of mating fan series

| Guard | F60P | F60UL | F80UL | F92UL | F120UL | F127UL | GUARD 172 | F180UL | F200UL | SCN | SCU |
|---------------|------|-------|-------|-------|--------|--------|-----------|--------|--------|-----|-----|
| AC Axial Fans | | | | | | | | | | | |
| SCU | | | | | ○*1 | | | | | | ○*2 |
| SCN | | | | | ○*1 | | | | | ○*2 | |
| VE | | | ○ | | | | | | | | |
| WE | | | | ○ | | | | | | | |
| KA | | | | ○ | | | | | | | |
| CU | | | | | ○ | | | | | | |
| CN | | | | | ○ | | | | | | |
| MA | | | | | | | | ○ | | | |
| PA | | | | | | | | ○ | | | |
| PL | | | | | | | | | ○ | | |
| DC Axial Fans | | | | | | | | | | | |
| TUDC | ○ | ○ | | | | | | | | | |
| PUDC | | | ○ | | | | | | | | |
| KUDC | | | | ○ | | | | | | | |
| DO925C | | | | ○ | | | | | | | |
| KLDC | | | | ○ | | | | | | | |
| CUDC | | | | | ○ | | | | | | |
| D1225C | | | | | ○ | | | | | | |
| CNDC | | | | | ○ | | | | | | |
| D1238T | | | | | ○ | | | | | | |
| D1238B | | | | | ○ | | | | | | |
| D1338B | | | | | | ○ | | | | | |
| D1338S | | | | | | ○ | | | | | |
| D1751M | | | | | | | ○ | | | | |
| D1751S | | | | | | | | ○ | | | |
| G0638D | | ○ | | | | | | | | | |
| B0838C | | | ○ | | | | | | | | |
| G0938B | | | | ○ | | | | | | | |
| G1238B | | | | | ○ | | | | ○ | | |
| G1751M | | | | | | | | ○ | | | |

*1: Can be installed only on outlet side. *2: Can be installed only on intake side.
All guards conform to the UL standard when combined with NIDEC SERVO fans.
The installation of a filter, guard and other accessories will constitute a ventilating load, reducing the airflow. Select a suitable guard, taking into consideration the increase in air resistance. (See Figs. 12 and 13 on page G-7.)

Filter

3-piece set

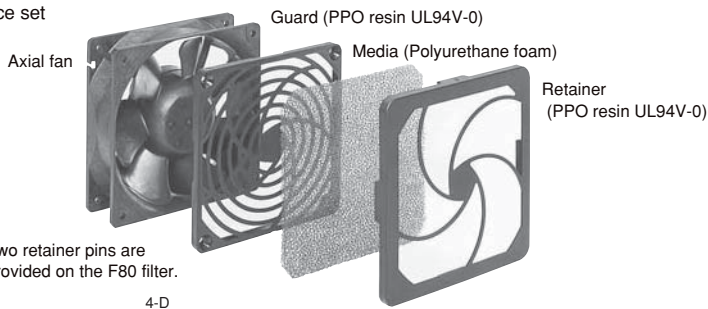

Note: Two retainer pins are provided on the F80 filter.

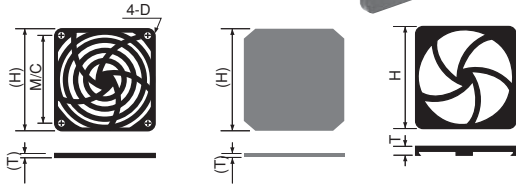

List of mating fan series

| Filter | F80 | F92 | F120 |
|--------|-----|-----|------|
| PUDC | ○ | | |
| KUDC | | ○ | |
| D0925C | | ○ | |
| KLDC | | ○ | |
| CUDC | | | ○ |
| D1225C | | | ○ |
| CNDC | | | ○ |
| D1238T | | | ○ |
| D1238B | | | ○ |
| G0838C | ○ | | |
| G0938B | | ○ | |
| G1238B | | | ○ |

| Filter | F80 | F92 | F120 |
|--------|-----|-----|------|
| VE | ○ | | |
| WE | | ○ | |
| KA | | ○ | |
| CU | | | ○ |
| CN | | | ○ |

| Component (Model Code) | H | T | M/C | D |
|------------------------|-------|------|-------|-------|
| F80 Filter | 83.6 | 10 | 71.5 | φ 3.8 |
| F92 Filter | 96.5 | 10 | 82.5 | φ 3.8 |
| F120 Filter | 123.7 | 10.7 | 104.8 | φ 4.6 |

Flange spacer

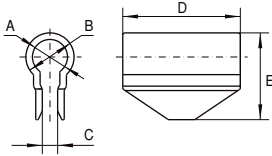

| Component (Model Code) | A mm | B mm | C mm | D mm | E mm | Mating Model Code |
|------------------------|------|------|------|------|------|-------------------|
| Flange Spacer PUDC (*) | 5 | 8 | 2 | 17 | 14.5 | KUDC,PUDC |
| Flange Spacer CUDC (*) | 8 | 11 | 3.5 | 15 | 19.8 | CUDC |
| Flange Spacer CNDC | 8 | 11 | 3.5 | 28 | 19.8 | CNDC |

※ Ribbed venturis (PUDC-R, CUDC-R) are available for PUDC and CUDC.

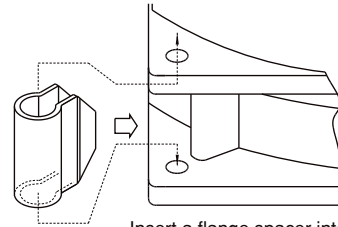

Insert a flange spacer into the ribs of a venturi.

(Installing a flange spacer)

Inlet ring

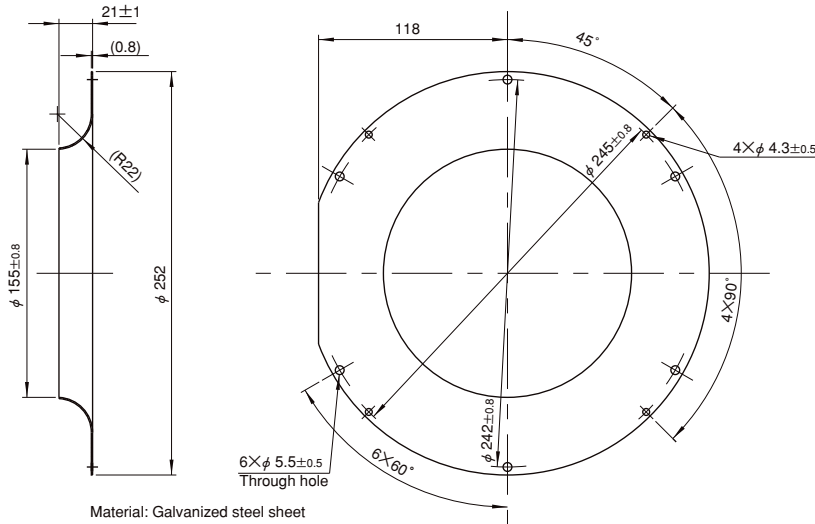

Material: Galvanized steel sheet

| Component (Model Code) | Mating Model Code |
|------------------------|-------------------|
| E2271 Inlet ring | E2271Z |

Plug cords for AC fans

(Common specification: Rated 3 A, voltage 250 V, dielectric strength 1 minute at 1500 V 50 Hz)

D2P1 cord (Mass 35 g)

Certified under the Electrical Appliance and Material Safety Law (Japan) (<PS>E mark approved)
Cord 0.18 dia. 30 conductors Black, heat resistant vinyl

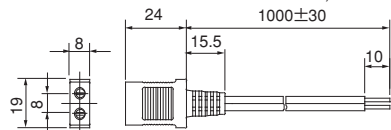

UL2P1 cord (Mass 41 g)

UL standard product (UL file No. E78112)
Cord 0.16 dia. 41 conductors Black, heat resistant vinyl

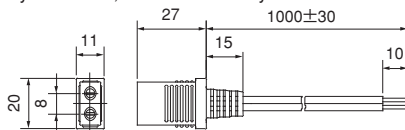

* UL2P2 cord with 2m length also available.

T2P1 cord

For wiring inside equipment
Cord 0.18 dia. 30 conductors Black, heat resistant vinyl

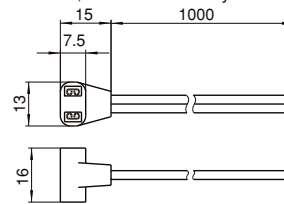

* T2P2 cord with 2m length also available.

D3P1 cord (Mass 59 g)

Certified under the Electrical Appliance and Material Safety Law (Japan) (<PS>E mark approved)
Cord:
For power feeding 0.18 dia. 30 conductors Black, heat resistant vinyl
For grounding 0.18 dia. 50 conductors Black, heat resistant vinyl

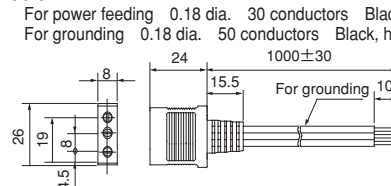

UL3P1 cord (Mass 60 g)

UL standard product (UL file No. E78112)
Cord:
For power feeding 0.16 dia. 41 conductors Black, heat resistant vinyl
For grounding AWG18 green/yellow spiral, heat resistant vinyl

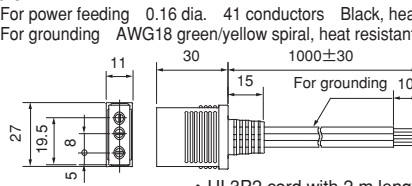

* UL3P2 cord with 2 m length also available.

PL sensor 1 cord

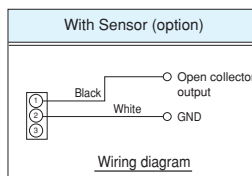
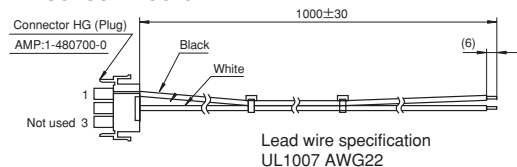

PL4P1 cord

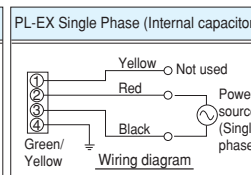
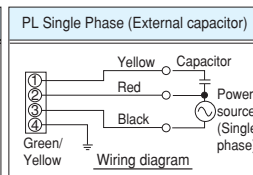
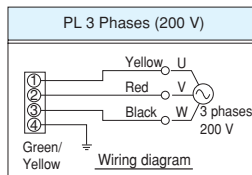
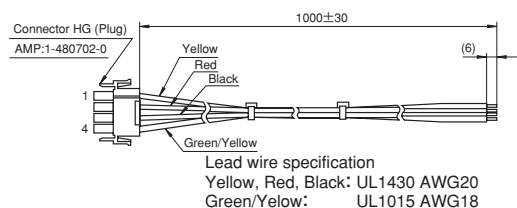

List of mating fan series

| Cord | T2P1 | T2P2 | D2P1 | D3P1 | UL2P1 | UL3P1 | PL4P1 | PL sensor |
|------------------|------|------|------|------|-------|-------|-------|-----------|
| WE | ○ | ○ | ○ | | ○ | | | |
| KA | ○ | ○ | ○ | | ○ | | | |
| CU | ○ | ○ | ○ | | ○ | | | |
| CN (2 terminals) | ○ | ○ | ○ | | ○ | | | |
| CN (3 terminals) | | | | ○ | | ○ | | |
| MA | ○ | ○ | ○ | | ○ | | | |
| PA | ○ | ○ | ○ | | ○ | | | |
| PL | | | | | | | ○ | ○ |

Plug cords for DC fans

DCLD030ST-ZZ01 (S sensor output cord)



DCLD030PT-ZZ01 (P sensor output cord)

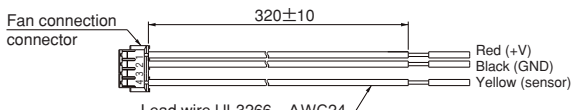

• Lead wire ends are sheathed to protect conductors. (Sheath peeling dimension 10±5)

| Component (Model Code) | Mating Model Code |
|------------------------|-------------------|
| DCLD030ST-ZZ01 | E1033H□□B□AM-04 |
| DCLD030PT-ZZ01 | |

A *Nidec* Group Company

SERVO

All for dreams™



|||| Motech

Motech srl - viale delle Nazioni, 89 41122 Modena (Mo)
phone +39 059 454296 fax +39 059 451693 info@motech-italia.com
www.motech-italia.com