



***Volta Belting
Technology***

/// Motech



The Next Step in Belting



Fruit & Vegetables Industry
Conveying Solutions



Clean, Process & Package with confidence on Volta conveyor belts for enhanced quality



Hygiene Inspired

Fresh produce gets added value from increased hygiene level.



Food Safety Focus

Avoid contamination and extend shelf life for healthy profits.

- ✓ Advanced cleanliness - belts have easy to clean surface that simplifies the sanitation process.
- ✓ Smooth homogeneous belts with no moving parts restrict the formation of pathogenic contamination in niches that harbor harmful organisms.
- ✓ Solid belt without fabric layers which soak up water, delaminate and form breeding grounds for impurities.
- ✓ Solid flexible material gently absorbs the impact of delicate falling produce.
- ✓ Volta's H material withstands the harsh effects of natural acidity released from raw produce. No cracking or deformation of top surface.
- ✓ Wide range of special impression top surfaces for non-stick or high grip applications.
- ✓ The SuperDrive™ positive drive concept with built-in guide mechanism prevents off-tracking and preserves the belt quality for long term use.
- ✓ Custom-made thermo-welded fabrications and easy onsite installation and repair.
- ✓ Greatly reduced noise levels.
- ✓ Reduce Cost of Ownership by at least 50% - superior lifetime, great water savings, less maintenance and downtime on critical workstations.

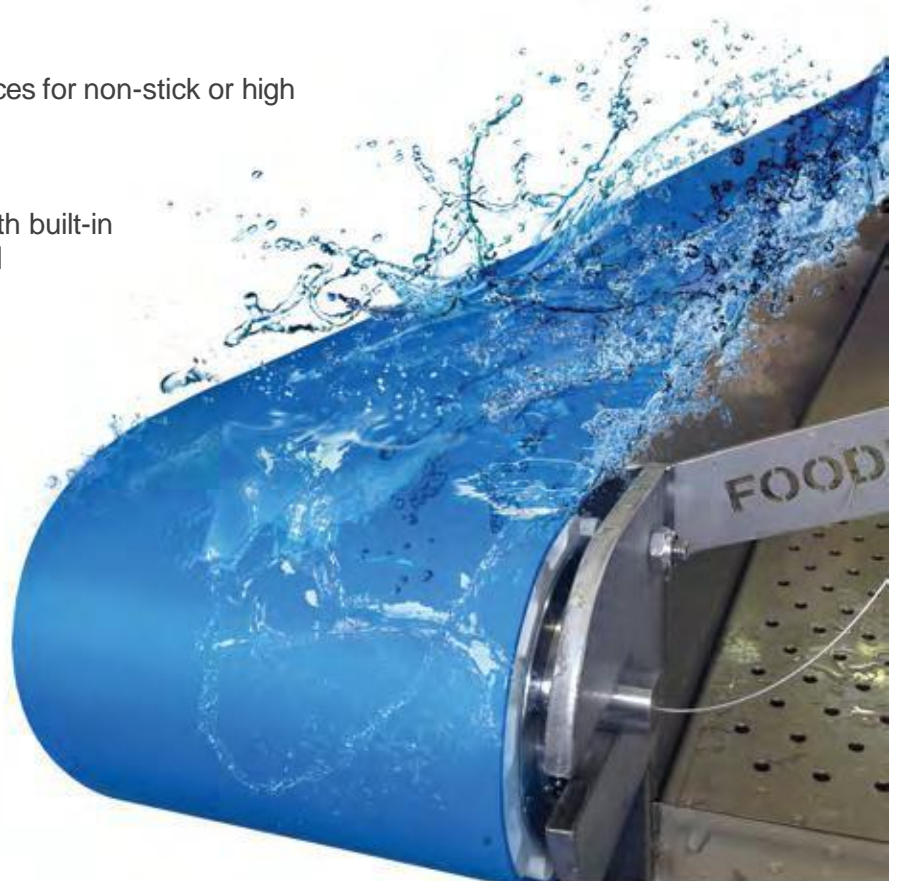

✓ Fresh Ready-to-Eat Salads and Leaves

Smooth belt surfaces prevent germs from lodging in gaps during processing. The structure is simple to clean, maintaining hygiene. In the processing of freshly-picked products, direct contact with Volta belts from washing until packing helps prevent raw produce from retaining impurities.



✓ Washing Leafy Greens

VOLTA perforated belts ensure a smooth through-flow while keeping bacteria levels down. It provides an ideal solution for drainage of water-runoff in the food cleaning process. No layers of fabric to obstruct the hole formation and no fiber ends left to contaminate your product.

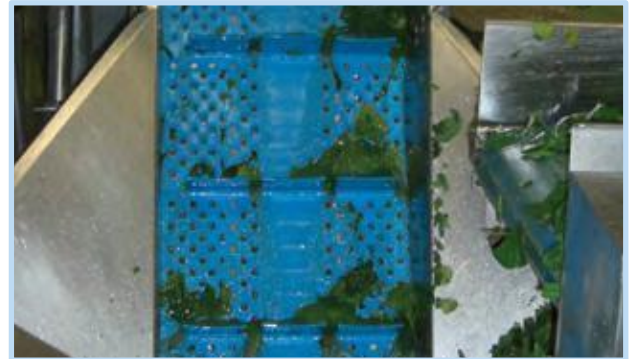

✓ Non-stick

The various textured easy release surfaces facilitate product discharge thereby contributing to keeping the belt cleaner for longer.

The fully extruded Mini Cleat (MC) top on our SuperDrive™ belt is an excellent choice for sliced peaches and pears.

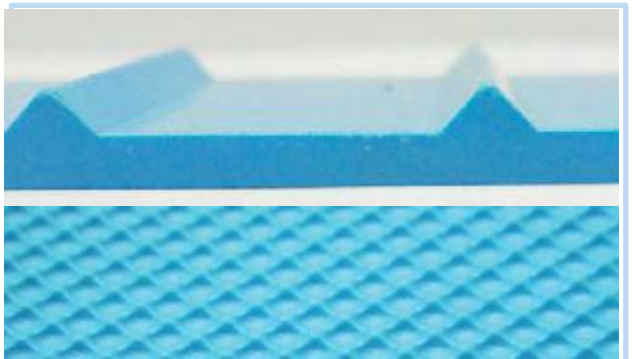

✓ SuperDrive™

The positive drive concept and built-in guide mechanism prevents off tracking and eliminates product wastage due to spillage. Performs well on elevators and Z conveyors.

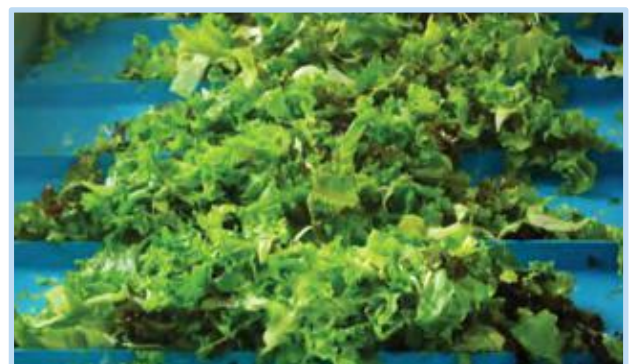

✓ Frozen Fruit & Vegetable Processing

The Volta Low Temperature (LT) flat belts are most suitable for working in environments with minus temperatures down to -35°C / -41°F and give optimal results in minus temperature applications. Perforations are also an excellent concept to consider for the circulation of air to flow in Individually Quick Frozen (IQF) applications.



✓ Bead Elevators

Welding solid Volta homogeneous flat material with high square flights, result in a tough fabrication and high performance belt for these machines. The Low coefficient of friction of Volta 'H' material suffers less from abrasion resulting from the belt continuously coming into contact with the conveyor casing thus increasing the belt life considerably.



✓ Hammocks & Slides

The flexible 'M' material is ideal for forming, and is used on potato intake chutes and other areas where a gentle transfer can prevent bruising. The belt material absorbs the impact of falling products, saving the majority of waste and rejects due to this condition.



✓ Canning

The extremely strong thermoplastic RCW reinforced profile displays outstanding wear resistance and is most suitable for conveying full and empty can applications. The low friction properties of this profile allows for smooth, constant conveying even where accumulation on the line may occur. Volta homogenous flat belts are used in conjunction with metal detectors and magnetic systems.



✓ Sorting Sleeves

VOLTA Sorting Sleeves used to cover rollers on fruit sorting machines are a great success. The belt material used is highly resistant to acids, cuts and abrasion and will not absorb any odors or liquids which make it particularly suitable for this application. The Volta belt will enhance the running of the rollers and ensure that the produce (oranges, apples, eggplants etc.) is moved along the sizing and sorting process line smoothly.



Material Quality Advantages

The harsh acidic nature of fruit and vegetables tend to wear away at the top surface of PVC and standard PU belts. The thick solid Volta 'H' material withstands the effects of these acids far better. Juices that are released during processing will not penetrate the homogeneous non-absorbent belt. No cracking, pitting or crumbling of the belt takes place.

Modular belts require strong water pressure and soaking to release clogging of products from gaps. Volta's smooth surface is quick and simple to clean.

Garlic, Onion:

Volta is highly non-absorbent to strong odors or acids released from these fresh products.



Grains, Rice, Beans:

Eliminate clogging and product wastage that lodge in the modular belt surface holes and hinges.



Potato:

Volta belts are highly resistant to the aggressive nature of starch which tends to corrode the belt surface.



Grapes, Pineapple:

High level of acidity. Volta belts withstand this threat.



Carrots:

The acidity of these products will not damage the belts.



Tomatoes:

Volta homogeneous belts prevent juice leaking into conveyor. Resistant to acidity.



Meets international hygiene standards for quality, reliability and food contact. FDA/USDA Approved. Declaration of Conformity verifying compliance with general requirements (article 3) in EU Regulations No.10/2011/EC, amended with Regulation (EU) 2017/752 and with Regulation (EU) 2020/1245 on plastic materials and articles of FCM, 1935/2004, 2023/2006, German Regulation BfR XXI and U.S. Food and Drug Administration 21 CFR 177.2600 (Rubber Articles). Supports HACCP Food Safety Management Principles.



Fruit & Vegetable Applications



Grapes Processing



Cabbage Elevator

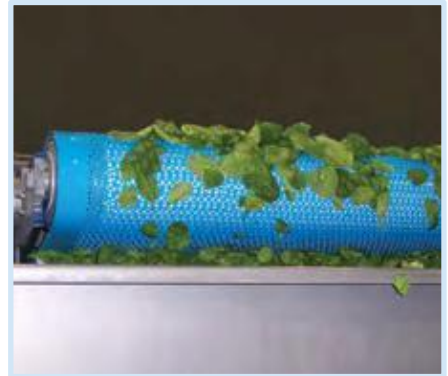

Spinach Washing



Rice Processing



Dates Sorting



Corn Cutting



Pineapple Canning



Mushroom Sorting



Corn Elevator

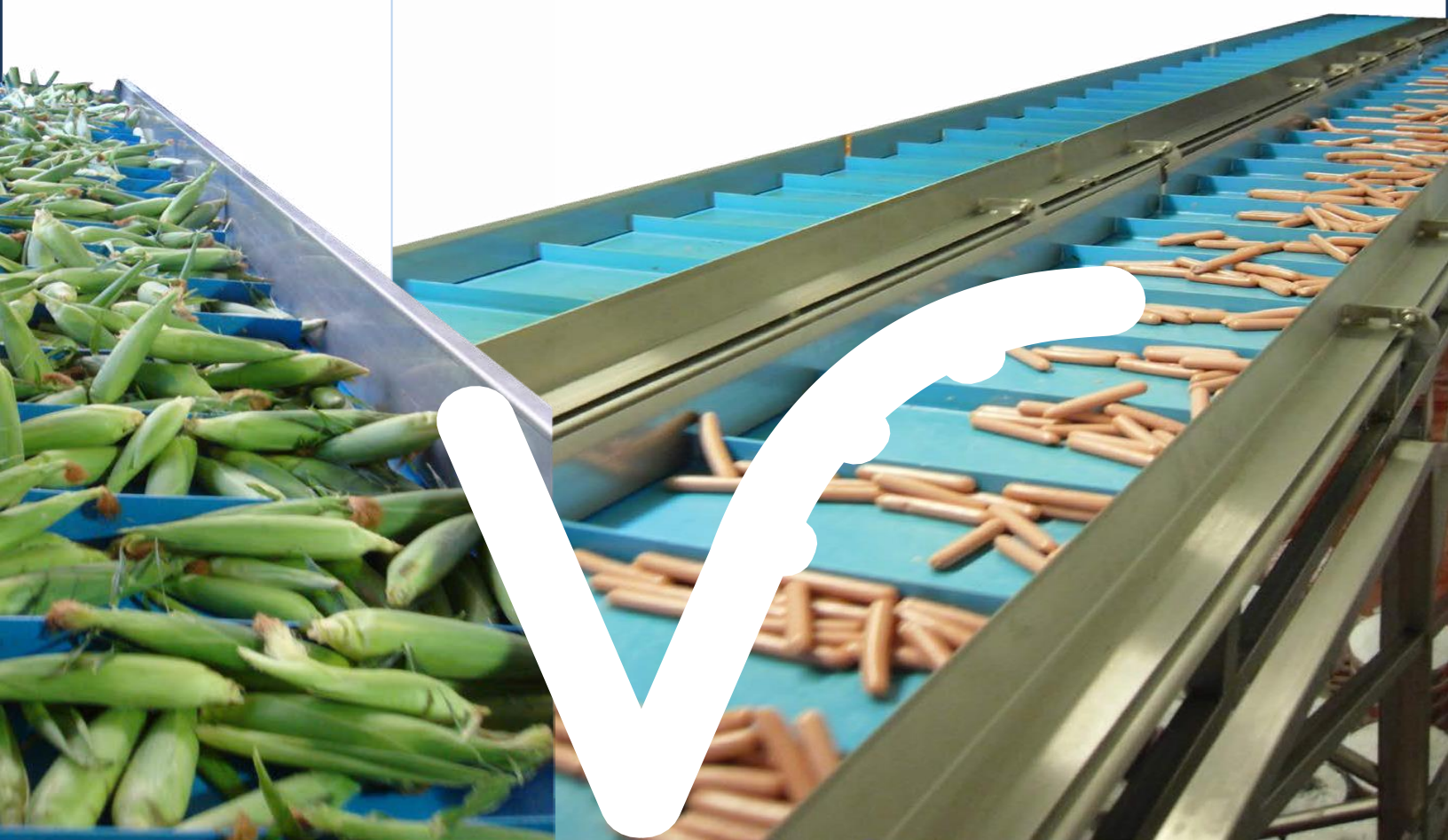

Flat Belts Food Industry
Conveying Solutions

/// Motech

- Volta has been manufacturing belts from homogenous Thermoplastic Elastomer (TPE) materials for over 55 years.
- The base belts are cut and abrasion resistant and have no ply or hinged elements which harbor bacteria.
- Volta products are the optimal choice where superior hygiene, conveying and cost efficiency are targets.

Homogeneous Belts											
Product & Color		Shore Hardness	Temperature Range	Coefficient of Friction on S.Steel (Bottom)	Thickness		Minimum Pulley Diameter		Pull Force: Pretension of 1%		Certifications
					mm		mm	Inch	kg/cm	lbs/in	
FHB	Blue16	59D	-20° C to 75° C -5° F to 170° F	0.28	2		70	2 ³ / ₄	2	11.20	FDA/USDA /EU
					3		90	3 ⁹ / ₁₆	3	16.80	
					4		110	4 ³ / ₈	4	22.40	
					5		150	5 ⁷ / ₈	5	28.00	
					6		180	7	6	33.60	
FHB	Blue13	59D	-20° C to 75° C -5° F to 170° F	0.28	4		110	4 ³ / ₈	4	22.40	FDA/USDA /EU
FHW	Off white	59D	-20° C to 75° C -5° F to 170° F	0.28	1.5		50	2	1.50	8.40	FDA/USDA /EU
					2		70	2 ³ / ₄	2	11.20	
					3		90	3 ⁹ / ₁₆	3	16.80	
					4		110	4 ³ / ₈	4	22.40	
					5		150	5 ⁷ / ₈	5	28.00	
					6		180	7	6	33.60	
FMB	Blue	95A/46D	-30° C to 70° C -20° F to 158° F	0.40	2.5		35	1 ³ / ₈	1.50	8.40	FDA/USDA /EU
					3		40	1 ⁵ / ₈	1.80	10.10	
					4		60	2 ³ / ₈	2.40	13.50	
					5		80	3 ¹ / ₈	3	16.90	
					6		90	3 ⁹ / ₁₆	3.60	20.25	
FMW	Beige	95A/46D	-30° C to 70° C -20° F to 158° F	0.40	2.5		35	1 ³ / ₈	1.50	8.40	FDA/USDA /EU
					3		40	1 ⁵ / ₈	1.80	10.10	
					4		60	2 ³ / ₈	2.40	13.50	
					5		80	3 ¹ / ₈	3	16.90	
					6		90	3 ⁹ / ₁₆	3.60	20.25	
FMWC	Clear	95A/46D	-30° C to 70° C -20° F to 158° F	0.40	2.5		35	1 ³ / ₈	1	8.40	FDA/USDA /EU
					3		40	1 ⁵ / ₈	1.2	6.70	
					4		60	2 ³ / ₈	1.6	9	
					5		80	3 ¹ / ₈	2	11	
					6		90	3 ⁹ / ₁₆	2.4	13.4	
FTB	Blue13	72A	-40° C to 40° C -40° F to 104° F	1.25	3		19	³ / ₄	0.57	3.2	FDA/ EU
Hydrolysis & Chemical Resistant (DR) Homogenous Belts											
FDR	Blue15	53D	-30° C to 70° C -20° F to 158° F	0.55	4		80	3 ¹ / ₁₆	2.4	13.5	FDA/USD A/ EU
Low Temperature (LT) Homogeneous Belts											
FMB-LT	Blue15	95A/46D	-35° C to 65° C -31° F to 149° F	0.36	3		40	1 ⁵ / ₈	1.20	6.70	FDA/ EU
					4		60	2 ³ / ₈	1.60	9	
					5		80	3 ¹ / ₈	2	11.20	
					6		90	3 ⁹ / ₁₆	2.40	13.40	
Metal Detectable (MD) Homogeneous Belts											
FMB-MD	Blue 09	95A	-20° C to 60° C -5° F to 140° F	0.50	3		75	3	1.80	10.1	FDA/ EU

Standard belt width = 1524mm (60"). Some of the belts are also available in 2032mm (80") width. Please contact Volta Belting representative for additional information.

Flat Belt Bottom Surfaces

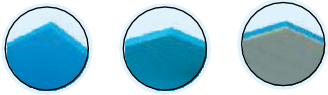

Smooth Embossed Reinforced

Flat Belt Impression Top Surfaces



ITM Matt Top ITS - 70 Impression Top Square ITO - 50 Impression Top Oval ITR -10 Impression Top Rough IRT Impression Roof Top SP Spikes CT Crescent Top MC Mini Cleats IST Impression Saw Tooth INT Impression NubTop ITP Impression Top Fine Points ITD - 60 Impression Top Diamond

Homogeneous Embossed Bottom Belts											
Product & Color			Shore Hardness	Temperature Range	Coefficient of Friction S.Steel (Bottom)	Thickness	Minimum Pulley Diameter		Pull Force: Pretension of 1%		Certifications
							mm	mm	Inch	kg/cm	
FBHB	Blue 16		59D	-20° C to 75° C -5° F to 170° F	0.20	3	90	3 ⁹ / ₁₆	3	16.80	FDA/USDA /EU
FEMB	Blue		95A/46D	-30° C to 70° C -20° F to 158° F	0.25	1.6	24	1 ⁵ / ₁₆	0.60	3.60	FDA/USDA /EU
						2	30	1 ³ / ₈	0.80	4.50	
						2.5	35	1 ³ / ₈	1	5.60	
						3	40	1 ⁵ / ₈	1.20	6.80	
						4	60	2 ³ / ₈	1.60	9.20	
FBMW	Beige		95A/46D	-30° C to 70° C -20° F to 158° F	0.25	5	80	3 ¹ / ₈	2.10	11.70	FDA/USDA /EU
						2	30	1 ³ / ₁₆	0.80	4.50	
						2.5	35	1 ³ / ₈	1	5.60	
						3	40	1 ⁵ / ₈	1.20	6.80	
						4	60	2 ³ / ₈	1.60	9.20	
FEMB-MD**	Blue 09		95A	-20° C to 60° C -5° F to 140° F	0.25	2	50	2	0.80	4.5	FDA/EU
						3	75	3	1.20	6.8	
FELB	Blue		80A	-40° C to 50° C -40° F to 120° F	0.45	1.6	10	3 ⁸ /	0.32	1.79	FDA/EU
						2	12	1 ² /	0.40	2.24	
						2.5	15	1 ⁹ / ₃₂	0.50	2.80	
						3	20	1 ³ / ₁₆	0.60	3.36	
FELB	Blue 02		80A	-40° C to 50° C -40° F to 120° F	0.45	1.6	10	3 ⁸ /	0.32	1.79	FDA/EU
						2	12	1 ² /	0.40	2.24	
FELW	White 16		80A	-40° C to 50° C -40° F to 120° F	0.45	1.6	10	3 ⁸ /	0.32	1.79	FDA/EU
						2	12	1 ² /	0.40	2.24	
						2.5	15	1 ⁹ / ₃₂	0.50	2.80	
						3	20	1 ³ / ₁₆	0.60	3.36	
						4	26	1 ¹³ / ₃₂	0.80	4.48	
FETB	Blue 10		72A	40° C to 40° C -40° F to 104° F	1	1.6	10	3 ⁸ /	0.29	1.6	FDA/EU
						2	13	1 ² /	0.36	2	
						3	19	3 ⁴ /	0.55	3	
Reinforced Belts											
FRMB	Blue		95A/46D	-30° C to 70° C -20° F to 158° F	0.20	2	25	1	6	33.50	FDA/USDA /EU
						3	35	1 ³ / ₈	7	39	
FRMW	Beige		95A/46D	-30° C to 70° C -20° F to 158° F	0.20	2	25	1	6	33.50	FDA/USDA /EU
						2.5	30	1 ³ / ₁₆	6.50	36.20	
						3	35	1 ³ / ₈	7	39	
						4	70	2 ³ / ₄	7.5	42	
FRLB	Blue		80A	-40° C to 50° C -40° F to 120° F	0.20	1.6	8	5 ¹ / ₁₆	4	22	FDA/ EU
						2	10	3 ⁸ /	5	28	
FRLW	White 16		80A	-40° C to 50° C -40° F to 120° F	0.20	1.6	8	5 ¹ / ₁₆	4	22	FDA/ EU
						2	10	3 ⁸ /	5	28	
						3	18	1 ¹¹ / ₁₆	7.50	42	
FRTB*	Blue 10		72A	-40° C to 40° C -40° F to 104° F	0.20	1.6	8	5 ¹ / ₁₆	2.60	14.90	FDA/ EU

Note: Standard belt width = 1524mm (60"). Some of the belts are also available in 2032mm (80") width. Please contact Volta Belting representative for additional information.

*FRTB-Blue10 - Pull Force (PF) calculated with Finger Splice welding.

**FEMB-MD-Blue09-Metal Detectable belt.

Impression Top Belts														
	Product & Color			Shore Hardness	Temperature Range	Coefficient of Friction on S.Steel (Bottom)	Thickness			Minimum Pulley Diameter		Pull Force: Pretension of 1%		Certifications
							mm	mm	Inch	kg/cm	lbs/in			
IT M	FEMB-ITM-LT*	Blue 15		95A/46D	-35°C to 50°C -20°F to 120°F	0.25	1	10	3/8	0.26	1.45	FDA/EU		
	FELB- ITS70	Blue		80A	-40°C to 50°C -40°F to 120°F	0.45	1.6 2	10 12	3/8 1/2	0.24 0.30	1.40 1.74	FDA/EU		
IST	FELB - IST	Blue		80A	-40°C to 50°C -40°F to 120°F	0.45	4**	35	1 3/8	0.40	2.20	FDA/EU		
ITD60	FLB -ITD60	Blue 02		80A	-40°C to 50°C -40°F to 120°F	0.55	2	12	1/2	0.46	2.58	FDA/EU		
	FELB - ITD60	Blue 02		80A	-40°C to 50°C -40°F to 120°F	0.45	1.8	11	7/16	0.3	1.68	FDA/EU		
ITO50	FELB - ITO50	Blue		80A	-40° C to 50° C -40° F to 120° F	0.45	2*	12	1/2	0.32	1.87	FDA/EU		
							2.5	15	9/16	0.40	2.32			
							3	18	11/16	0.50	2.80			
							5	35	1 3/8	0.90	5			
	FELB - ITO50	Blue 02		80A	-40° C to 50° C -40° F to 120° F	0.45	3	18	11/16	0.50	2.80	FDA/EU		
	FMB-ITO50	Blue		95A/46D	-30°C to 70°C -20°F to 158°F	0.36	2.5	35	1 3/8	1.50	8.40	FDA/USDA/ EU		
	FEMB-ITO50	Blue		95A/46D	-30°C to 70°C -20°F to 158°F	0.25	2	30	1 3/16	0.60	3.36	FDA/USDA/ EU		
							3	40	1 5/8	0.94	5.26			
FEMW-ITO50	Beige		95A/46D	-30°C to 70°C -20°F to 158°F	0.25	2.5 3	35 40	1 3/8 1 5/8	0.74 0.94	4.20 5.26	FDA/USDA/ EU			
FEMB -ITO50-MD**	Blue 09		95A	-20°C to 60°C -5°F to 140°F	0.25	2 3	50 75	2 3	0.60 1	3.36 5.6	FDA/EU			
ITR10	FELW - ITR10	White16		80A	-40°C to 50°C -40°F to 120°F	0.45	4	25	1	0.70	3.92	FDA/ EU		
IRT	FELB - IRT	Blue		80A	-40°C to 50°C -40°F to 120°F	0.45	4	25	1	0.60	3.40	FDA/USDA/ EU		
	FEMB - IRT	Blue		95A/46D	-30°C to 70°C -20°F to 158°F	0.25	3.5	40	1 5/8	1	5.60	FDA/EU		
Spikes SP**	FELB-SP	Blue		80A	-40°C to 50°C -40°F to 120°F	0.45	2	20	1 3/16	0.40	2.24	FDA/USDA/ EU		
							2.5	24	1 5/16	0.50	2.80			
							3	28	1 1/8	0.60	3.36			
	FEMB-SP	Blue		95A/46D	-30°C to 70°C -20°F to 158°F	0.25	2	40	1 5/8	0.80	4.50	FDA/USDA/ EU		
							2.5	45	1 3/4	1	5.60			
							3	50	2	1.20	6.80			
FEMW-SP	Blue		95A/46D	-30°C to 70°C -20°F to 158°F	0.25	2	40	1 5/8	0.80	4.50	FDA/USDA/ EU			
						2.5	45	1 3/4	1	5.60				
IT P	FELB - ITP	Blue 02		80A	-40°C to 50°C -40°F to 120°F	0.45	2	12	1/2	0.40	2.24	FDA/EU		
INT	FEMB - INT	Blue		95A/46D	-30°C to 70°C -20°F to 158°F	0.25	2	50	2	0.80	4.50	FDA/USDA /EU		
CT	FELB - CT	Blue		80A	-40°C to 50°C -40°F to 120°F	0.45	3	35	1 3/8	0.60	3.36	FDA/EU		
Crescent Top - CT	FMB - CT	Blue		95A/46D	-30°C to 70°C -20°F to 158°F	0.36	3	60	2 3/8	1.80	10.12	FDA/USDA /EU		
	FEMB - CT	Blue		95A/46D	-30°C to 70°C -20°F to 158°F	0.25	3	60	2 3/8	1.20	6.75	FDA/USDA /EU		
	FEMW - CT	Beige		95A/46D	-30°C to 70°C -20°F to 158°F	0.25	2.5	50	2	1	5.60	FDA/USDA /EU		
	FEMB - CT-MD**	Blue 09		95A	-20°C to 60°C -5°F to 140°F	0.25	3	95	3 3/16	1.2	6.75	FDA/EU		
Mini Cleats	FELB - MC	Blue		80A	-40°C to 50°C -40°F to 120°F	0.45	2.5	40	1 5/8	0.50	2.80	FDA/EU		
	FEMB - MC	Blue		95A/46D	30°C to 70°C -20° F to 158°F	0.25	3	70	2 3/4	1.20	6.80	FDA/USDA /EU		

Standard belt width = 1524mm (60").Some of the belts are also available in 2032mm (80") width. Please contact Volta Belting representative for additional information.

Note: *FEMB-ITM-LT - Min. Pulley diameter for temperature ≥5°C / 41°F. *FELB-2-ITO50 - not standard.

** FELB-IST - Base - 2mm; total belt height 4mm. **Spikes -Height of Spikes above base belt is 2.8mm.

**FEMB-ITO50-MD & FEMB-CT-MD-Blue09-Metal Detectable belts.

Reinforced Impression Top Belts

Product & Color			Shore Hardness	Temperature Range	Coefficient of Friction on S.Steel (Bottom)	Thickness		Minimum Pulley Diameter		Pull Force: Pretension of 1%		Certifications
						mm		mm	Inch	kg/cm	lbs/in	
FRMB - ITO50	Blue		95A/46D	30° C to 70° C -20° F to 158°	0.20	2.5		32	1 ¼	4.10	24	FDA/USDA /EU
FRMW - ITO50	Beige		95A/46D	30° C to 70° C	0.20	2.5		32	1 ¼	4.10	24	FDA/USDA /EU
						3		36	1 7/16	4.30	25.20	
FRLB - ITO50	Blue		80A	-40° C to 50° C -40° F to 120° F	0.20	2.5		15	9/16	3.20	18	FDA/EU
FRLW - ITO50	White 16		80A	-40° C to 50° C -40° F to 120° F	0.20	2.5		15	9/16	3.20	18	FDA/EU
						3		18	11/16	3.48	21.60	
FRLW - ITR10	White 16		80A	-40° C to 50° C -40° F to 120° F	0.20	4		30	1 3/16	3.40	19	FDA/EU
FRLB - ITS70	Blue 02		80A	-40° C to 50° C	0.20	2		10	3/8	5	28	FDA/EU

Covered Bottom Flat Belts

Ideal for special applications, for example in bakeries and confectioneries where reinforcement is necessary and hygiene cannot be compromised. The fabric reinforcement is thermally-coated with a thin layer of Volta TPE to provide a seal, preventing both contamination and delamination. As an extra precaution, belt edges can be thermo-sealed or recessed to prevent fraying and the ingress of contaminants.



Fabric Reinforcement coated with homogeneous Volta material.

Covered Bottom/ Covered Bottom Impression Top Belts

Product & Color			Shore Hardness	Temperature Range	Coefficient of Friction on S.Steel (Bottom)	Thickness		Minimum Pulley Diameter		Pull Force: Pretension of 1%		Certifications
						mm		mm	Inch	kg/cm	lbs/in	
FRLB - CEB - B	Blue		80A	-40° C to 50° C -40° F to 120° F	0.30	2		19	3/4	2.20	12.40	FDA/EU
FRLW - CEB - C	White 16				0.30	3		30	1 ¼	2.80	15.60	FDA/EU
FRLW - CB	White 16				0.40	2		19	3/4	3.10	17.40	FDA/EU
FRMB - CEB - B	Blue		95A/46D	-30°C to 60°C -20°F to 120°F	0.30	0.80		12	1 5/3	3.50	19.6060	FDA/USDA /EU
					0.30	3		40	1 5/8	4.80	38	
FRMW - CEB - C	Beige		95A/46D	-30°C to 60°C -20°F to 120°F	0.30	3		40	1 5/8	4.80	38	

Belt Coating Materials for the Food Industry

Products	GIB*-Blue17	MIB*-Blue17	WIB*-Blue17	FEIB-Blue-17	FEMB-SP-Blue FEMW-SP-Beige	FELB-SP-Blue	FELB-IST-Blue
Illustration							
Description	Super Grip	Multi Grip	Wood Grip	High Grip	Spikes**	Spikes**	Saw Tooth
Hardness	62A	62A	62A	62A	95A	80A	80A
Size (mm)	Width*	50	50	70	1524	1524	1524
	Thickness	4	6	4	2/2.5/3	2/2.5/3	4***
CoF (Stainless Steel)	0.98	1.08	1.05	0.95	0.25	0.45	0.45
Temperature Range	-20° C to 40° C				-30° C to 70° C		-40° C to 50° C
Certifications	FDA/EU				FDA/USDA/EU		FDA/ EU

Note: *Width - Maximum available width | * For dry use only | ** Height of Spikes above the base belt is 2.8mm | *** FELB-IST - Total belt thickness.

Aramid Cord Reinforced Belts

A food grade flat belt with special tensioning members, hermetically encased in non-porous homogeneous material which has been tested for durability. Used mainly in applications with significant loads on long narrow belts with small diameter pulleys.

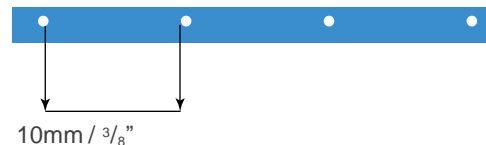

Aramid Cord Reinforced (ACR) Embossed Bottom Belts

Product & Color		Shore Hardness	Temperature Range	Coefficient of Friction on S.Steel (Bottom)	Thickness	Minimum Pulley Diameter		Pull Force: Pretension of 0.2%		Certifications
						mm	Inch	kg/cm	lbs/in	
FELB-ACR	Blue	80A	-40°C to 50°C -40°F to 120°F	0.45	2.5	20	0.79	4	22.40	FDA/EU

Aramid Cord Reinforced (ACR) Impression Top & Embossed Bottom Belts

FELB-ACR-ITO50	Blue	80A	-40°C to 50°C -40°F to 120°F	0.45	2.5	20	0.79	4	22.40	FDA/EU
FELB-ACR-ITO50	Blue 02	80A	-40°C to 50°C -40°F to 120°F	0.45	2.5	20	0.79	4	22.40	FDA/EU
FELB-ACR-IST	Blue 02	80A	-40°C to 50°C -40°F to 120°F	0.45	4*	35	1.38	4.2	23.40	FDA/EU

Low Temperature (LT) Aramid Cord Reinforced (ACR) Impression Top & Embossed Bottom Belts

FELB-ACR-ITO50-LT	Blue 15	80A	-40°C to 50°C -40°F to 120°F	0.45	2.5	18	0.70	4	22.40	FDA/EU
FEMB-LT ITO50-ACR	Blue 15	95A/46D	-35°C to 50°C -30°F to 120°F	0.25	2.5	40	1.57	4	22.40	FDA/EU

Note: Standard belt width = 1524mm (60"). Some of the belts are also available in 2032mm (80") width. Please contact Volta Belting representative for additional information.
*FELB-ACR-IST – Base belt thickness = 2mm // Total belt thickness including Saw tooth impression top = 4mm.
Pull force in table relates to a finger splice weld 20x50 mm. The calculation takes into account the weld splice which has strength of 28kg/cm. Note that various finger splice methods and different tools can result in differing belt strengths.

Endless Splicing Techniques

FBW - Flat Butt Welding System The FBW System performs a butt-weld, fusing belts edge to edge.



FT - Electrode Welding System The FT Welding System provides electrode welding technology.

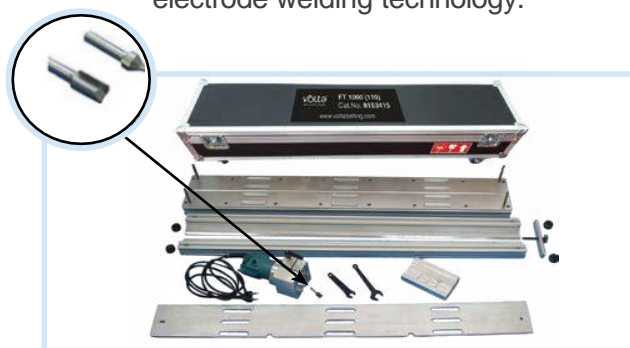

Volta RoundFlex™ Lace

New, improved geometry for a better grip on pulleys. Compatible with Volta MB, MW, MB-MD and DR material belts from 2.5 to 5mm thickness. All Volta flat belt materials are easy to clean without removing from conveyor and therefore lace is used only where absolutely necessary. The strength of the belt will be affected at the joint where lace is used.

RoundFlex™ Lace

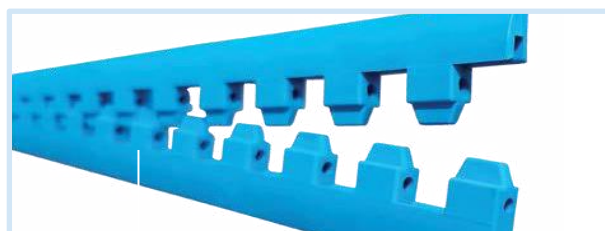



The Next Step in Belting

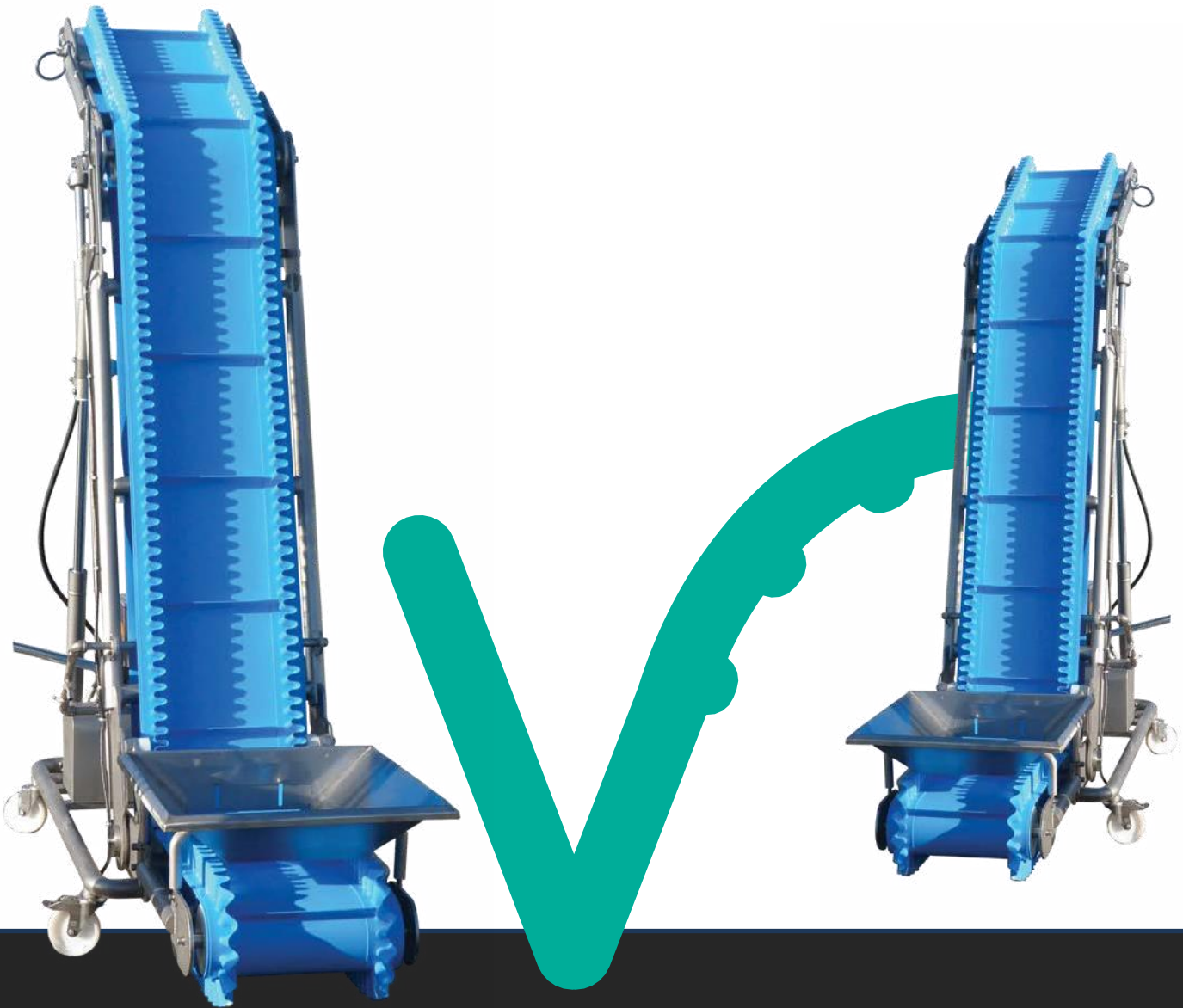

Food Grade Positive Drive Line
Conveying Solutions



SuperDrive™

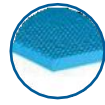

ITE
Impression
Top Embossed

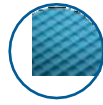

ITO-50
Impression
Top Oval

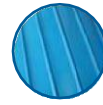

MC
Mini
Cleats

The homogeneous Positive Drive, recognized worldwide as the best choice where hygiene and conveying efficiency are essential.

Smooth Top SuperDrive™ Belts											
Product & Color		Shore Hardness	Temperature Range	Coefficient of Friction on UHMW	Thickness	Minimum Pulley Diameter		Maximum Pull Force		Certifications	
						mm	mm	Inch	kg/cm		lbs/in
FHB-SD	Blue 16	55D	-20°C to 90°C -5°F to 194°F	0.20	3	126	4 ³¹ / ₃₂	7	39.2	FDA/USDA/EU	
					4	176	6 ¹⁵ / ₁₆	9	50.40		
					6	300	11 ¹³ / ₁₆	14	78.40		
FHW-SD	Off White	55D	-20°C to 90°C -5°F to 194°F	0.20	3	126	4 ³¹ / ₃₂	7	39.2	FDA/USDA/EU	
					4	176	6 ¹⁵ / ₁₆	9	50.40		
FHB-SD	Blue 13	55D	-20°C to 90°C -5°F to 194°F	0.20	3	126	4 ³¹ / ₃₂	7	39.2	FDA/USDA/EU	
					4	176	6 ¹⁵ / ₁₆	9	50.40		
FEHB-SD-ITM2	Blue 16	55D	-20°C to 90°C -5°F to 194°F	0.18	3	126	4 ³¹ / ₃₂	7	39.2	FDA/USDA/EU	
					4	176	6 ¹⁵ / ₁₆	9	50.40		
FMB-SD	Blue	53D	-20°C to 70°C -5°F to 158°F	0.28	3	80	3 ¹ / ₄	6.25	35	FDA/USDA/EU	
					4	120	4 ³ / ₄	8	44.80		
					6	240	9 ³ / ₄	12.50	70		
FMW-SD	Beige	53D	-20°C to 70°C -5°F to 158°F	0.28	3	80	3 ¹ / ₄	6.25	35	FDA/USDA/EU	
					4	120	4 ³ / ₄	8	44.80		
FMB-SD	Blue 02	53D	-20°C to 70°C -5°F to 158°F	0.28	3	80	3 ¹ / ₄	6.25	35	FDA/USDA/EU	
FEMB-SD-ITM2	Blue	53D	-20°C to 70°C -5°F to 158°F	0.22	3	80	3 ¹ / ₄	6.25	35	FDA/USDA/EU	
					4	120	4 ³ / ₄	8	44.80		
Impression Top SuperDrive™ Belts											
FHB-SD-ITO50	Blue 16	55D	-20°C to 90°C -5°F to 194°F	0.20	3	126	4 ³¹ / ₃₂	7	39.2	FDA/USDA/EU	
					4	176	6 ¹⁵ / ₁₆	9	50.40		
FHB-SD-ITE	Blue 16	55D	-20°C to 90°C -5°F to 194°F	0.20	3	126	4 ³¹ / ₃₂	7	39.2	FDA/USDA/EU	
FMB-SD-ITO50	Blue	53D	-20°C to 70°C -5°F to 158°F	0.28	3	80	3 ¹ / ₄	6.25	35	FDA/USDA/EU	
FMB-SD-ITE	Blue	53D	-20°C to 70°C -5°F to 158°F	0.28	3	80	3 ¹ / ₄	6.25	35	FDA/USDA/EU	
FMW-SD-ITE	Beige	53D	-20°C to 70°C -5°F to 158°F	0.28	3	80	3 ¹ / ₄	6.25	35	FDA/USDA/EU	
FMB-SD-MC	Blue	53D	-20°C to 70°C -5°F to 158°F	0.28	3	100	4	6.25	35	FDA/USDA/EU	
Hydrolysis & Chemical Resistant SuperDrive™ Belts											
FDR-SD	Blue 15	53D	-20°C to 70°C -5°F to 158°F	0.30	3	80	3 ¹ / ₄	4.7	26.3	FDA/USDA/EU	
					4	120	4 ³ / ₄	6.25	35		
FDR-SD-ITO50	Blue 15	53D	-20°C to 70°C -5°F to 158°F	0.30	3	80	3 ¹ / ₄	4.7	26.3	FDA/USDA/EU	
FEDR-SD-ITM2	Blue 15	53D	-20°C to 70°C -5°F to 158°F	0.22	3	80	3 ¹ / ₄	4.7	26.3	FDA/USDA/EU	
FEDR-SD-ITO50	Blue 15	53D	-20°C to 70°C -5°F to 158°F	0.22	3	80	3 ¹ / ₄	4.7	26.3	FDA/USDA/EU	
Low Temperature (LT) SuperDrive™ Belts											
FMB-SD-LT	Blue 15	95A/46D	-35°C to 65°C -31°F to 149°F	0.30	3	80	3 ¹ / ₄	3	16.80	FDA/EU	
Metal Detectable (MD) SuperDrive™ Belt											
FMB-SD-MD	Blue 09	53D	-20°C to 60°C -5°F to 140°F	0.28	3	100	4	6	33.6	FDA/EU	
FMB-SD-ITO50-MD	Blue 09	53D	-20°C to 60°C -5°F to 140°F	0.28	3	100	4	6	33.6	FDA/EU	

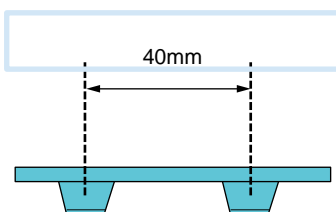

Pitch size for reference only

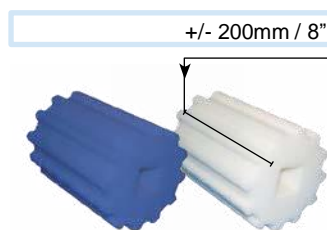

SuperDrive™ Drive Pulley

11

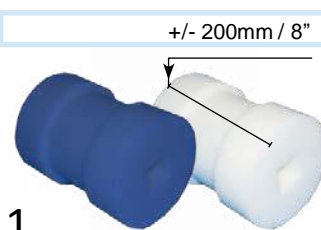

SuperDrive™ Tail Pulley

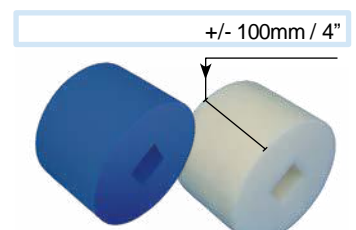

SuperDrive™ Support Pulley

Mini SuperDrive™

Food Grade - Positive Drive Line

The only trackable Mini Positive Drive product.

The MiniSD™ design is similar to the world leader, Volta SuperDrive™; scaled down for a smaller minimum pulley. Standard belt width: 1524mm/60" or 2032mm/80". Please contact Volta Belting representative for additional information.

Smooth Top Mini SuperDrive™ Belts											
Product & Color		Shore Hardness	Temperature Range***	Coefficient of Friction on UHMW	Thickness	Minimum Pulley Diameter*		Maximum Pull Force**		Certifications	
						mm	mm	Inch	kg/cm		lbs/in
FHB-MSD	Blue 16	55D	-20°C to 90°C -5°F to 194°F	0.20	2	80	3.15	4.5	25.2	FDA/USDA/EU	
					2.5	100	4	5.6	31.36		
FMB-MSD	Blue	95A/46D	-20°C to 70°C -5°F to 158°F	0.28	2.5	48	1.89	4	22.4	FDA/USDA/EU	

Impression Top Mini SuperDrive™ Belts											
Product & Color		Shore Hardness	Temperature Range***	Coefficient of Friction on UHMW	Thickness	Minimum Pulley Diameter*		Maximum Pull Force**		Certifications	
FMB-MSD-ITO50	Blue	95A/46D	-20°C to 70°C -5°F to 158°F	0.28	2.5	48	1.89	4	22.4	FDA/USDA/EU	
FMB-MSD-MC	Blue	95A/46D	-20°C to 70°C -5°F to 158°F	0.28	2.5	80	3.15	4	22.4	FDA/USDA/EU	

Note: * Minimum Pulley Diameter – Normal Flex. Dimensions are relevant for an ambient temperature above 0°C / 32°F.

** Maximum Pull Force – in kg/cm width & lb/in width.

***To determine the allowable Pull force, check the "Temperature Correction Factor" table.

Declaration of Conformity in compliance with Food Contact Regulations: EU No.-10/2011 amended by 2017/752, 1935/2004 and 2023/2006 and FDA Art. 21. CFR.177.2600. Compatible with HACCP principles.

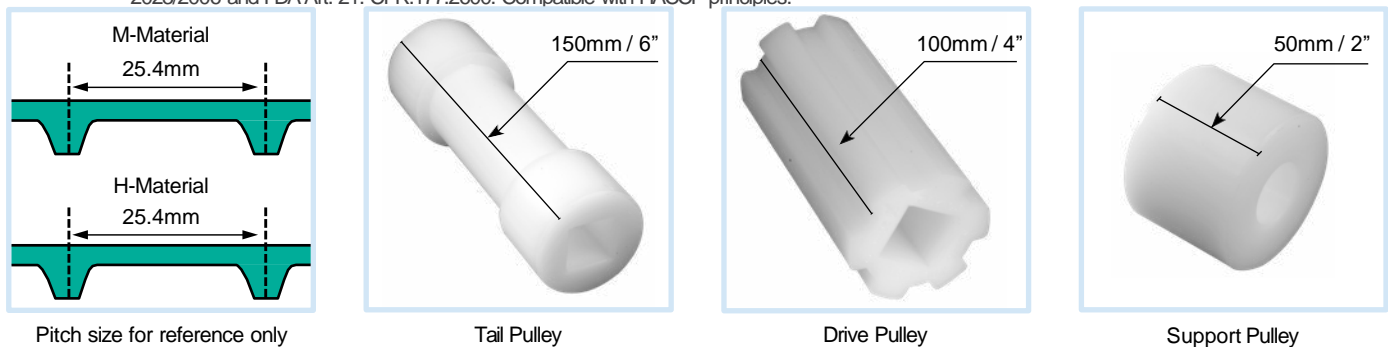

Mini DualDrive™

A scaled-down version of the original DualDrive™ tooth geometry. Standard belt width: 2032mm/80".

Smooth Top Mini DualDrive™ Belts											
Product & Color		Shore Hardness	Temperature Range***	Coefficient of Friction on UHMW	Thickness	Minimum Pulley Diameter*		Maximum Pull Force**		Certifications	
						mm	mm	Inch	kg/cm		lbs/in
FMB-MDD	Blue	95A/46D	-20°C to 70°C -5°F to 158°F	0.28	2.5	48	1.89	4	22.4	FDA/USDA/EU	

Impression Top Mini DualDrive™ Belts											
Product & Color		Shore Hardness	Temperature Range***	Coefficient of Friction on UHMW	Thickness	Minimum Pulley Diameter*		Maximum Pull Force**		Certifications	
FMB-MDD-ITO50	Blue	95A/46D	-20°C to 70°C -5°F to 158°F	0.28	2.5	48	1.89	4	22.4	FDA/USDA/EU	

Note: * Minimum Pulley Diameter – Normal Flex. Dimensions are relevant for an ambient temperature above 0°C / 32°F.

** Maximum Pull Force – in kg/cm width & lb/in width.

***To determine the allowable Pull force, check the "Temperature Correction Factor" table. Declaration of Conformity in compliance with Food Contact Regulations: EU No.-10/2011 amended by 2017/752, 1935/2004 and 2023/2006 and FDA Art. 21. CFR.177.2600. Compatible with HACCP principles.

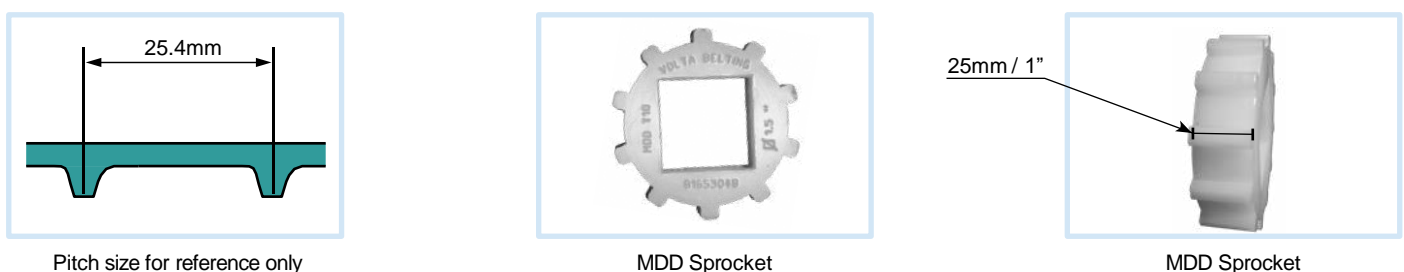

DualDrive™

- Minimal retrofitting required. DualDrive™ is suited to some 2" pitch modular belt sprockets but for both reliability and hygiene these should be replaced.
- DualDrive™ is a fully extruded Positive Drive belt with drive teeth running the full width of the belt at a 2" pitch.

Mechanical Benefits:

- Replaces modular systems that require extensive cleaning and lengthy soaking and wear quickly at the joints.
- Greatly reduced noise levels in comparison with to modular belts.
- Integrated teeth for a Positive Drive with no slippage.
- No pretension of the belt is needed.
- Extruded in 30 or 60m (100 or 200ft) length and 1524mm (60") width.

Material Features:

- Smooth or textured homogeneous surface.
- Special texture available for non-stick applications.
- No ply/fraying of fibers.
- Easy and effective cleaning.
- No cracks or crevices that can potentially harbor bacteria.

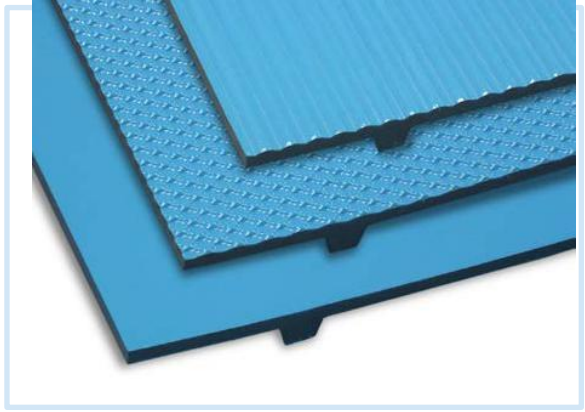
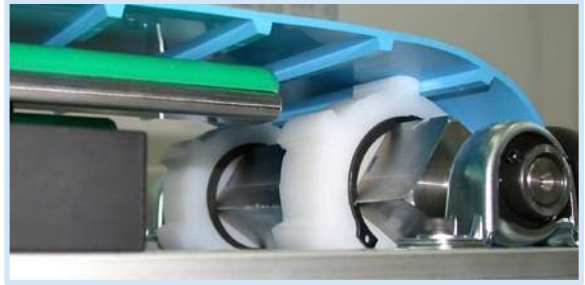

Smooth Top DualDrive™ Belts											
Product & Color		Shore Hardness	Temperature Range	Coefficient of Friction on UHMW	Thickness	Minimum Pulley Diameter		Maximum Pull Force		Certifications	
						mm	mm	Inch	kg/cm		lbs/in
FHB-DD	Blue 16	55D	-20°C to 90°C -5°F to 194°F	0.20	3	126	4 ^{31/32}	7	39.2	FDA/USDA/EU	
FHB-DD	Blue 02	53D	-20°C to 90°C -5°F to 194°F	0.28	3	80	3 ^{1/4}	6	33.6	FDA/USDA/EU	
FMB-DD	Blue	53D	-20°C to 70°C -5°F to 158°F	0.28	3	80	3 ^{1/4}	6	33.6	FDA/USDA/EU	
FMB-DD-ITM2	Blue	53D	-20°C to 70°C -5°F to 158°F	0.28	4	120	4 ^{3/4}	7.7	43	FDA/USDA/EU	
FMW-DD	Beige	53D	-20°C to 70°C -5°F to 158°F	0.28	3	80	3 ^{1/4}	6	33.6	FDA/USDA/EU	
FMW-DD-ITM2	Beige	53D	-20°C to 70°C -5°F to 158°F	0.28	3	80	3 ^{1/4}	6	33.6	FDA/USDA/EU	
Impression Top DualDrive™ Belts											
FMB-DD-ITO50	Blue	53D	-20°C to 70°C -5°F to 158°F	0.28	3	80	3 ^{1/4}	6	33.6	FDA/USDA/EU	
FMB-DD-IRT	Blue	53D	-20°C to 70°C -5°F to 158°F	0.28	4	100	4	6	33.6	FDA/USDA/EU	
Hydrolysis & Chemical Resistant DualDrive™ Belts											
FDR-DD	Blue 15	53D	-20°C to 70°C -5°F to 158°F	0.30	3	80	3 ^{1/4}	4.7	26.3	FDA/USDA/EU	
FDR-DD-ITM2	Blue 15	53D	-20°C to 70°C -5°F to 158°F	0.30	3	80	3 ^{1/4}	4.7	26.3	FDA/USDA/EU	
Low Temperature (LT) DualDrive™ Bel											
FMB-DD-LT	Blue 15	95A/46D	-35°C to 65°C -31°F to 149°F	0.30	3	80	3 ^{1/4}	3	16.80	FDA/EU	
Metal Detectable (MD) DualDrive™ Belt											
FMB-DD-MD	Blue 09	53D	-20°C to 60°C -5°F to 140°F	0.28	3	100	4	6	33.6	FDA/EU	

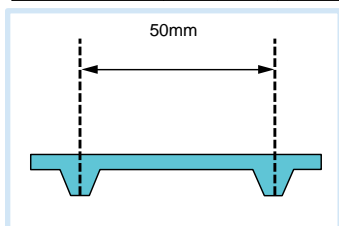

Pitch size for reference only

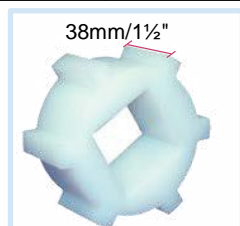

Machined Drive Sprockets



Machined Drive Sprockets



Molded Drive Sprocket



Molded Tail Roller

Volta RoundFlex™ Lace

New, improved geometry for a better grip on pulleys. Compatible with Volta MB, MW, MB-MD and DR material Flat and Positive Drive belts including MSD & MDD belts from 2.5 to 5mm thickness.

All Volta belt materials are easy to clean without removing from conveyor and therefore we only recommend lace when absolutely necessary. The strength of the belt will be affected at the joint where lace is used.

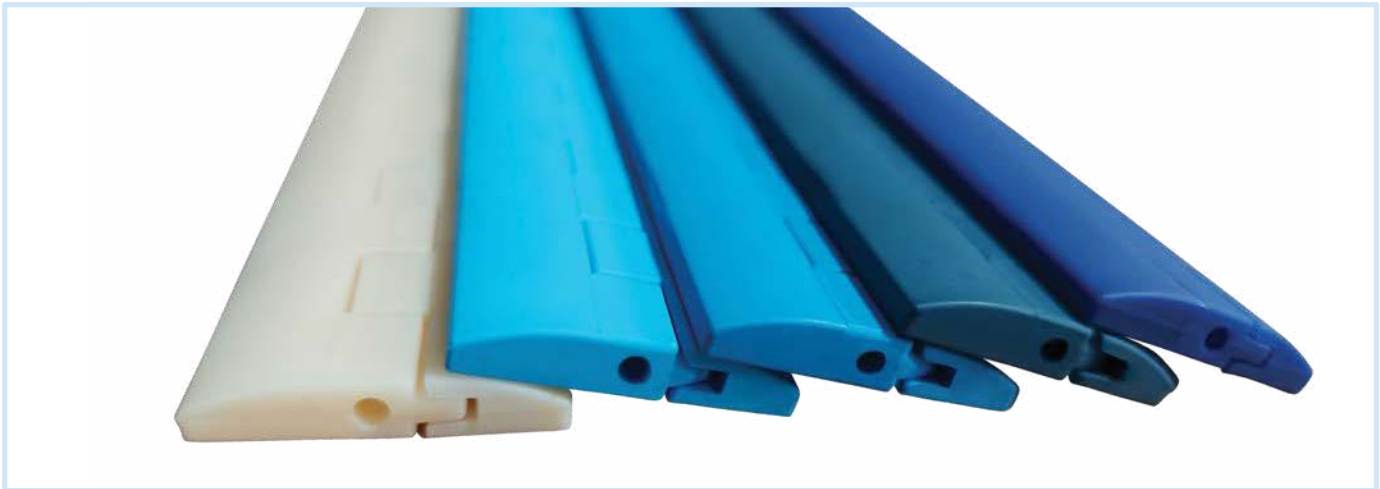

RoundFlex™ Lace

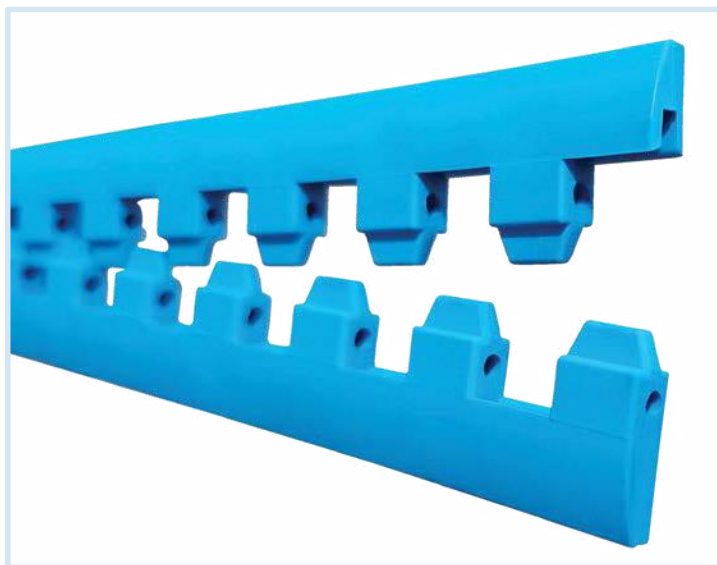

RoundFlex™ Lace

We are committed to providing a complete package focusing on servicing our customers all the way, up until the belts are safely installed and the conveyor is running smoothly.

Fabrications on Positive Drive Belts

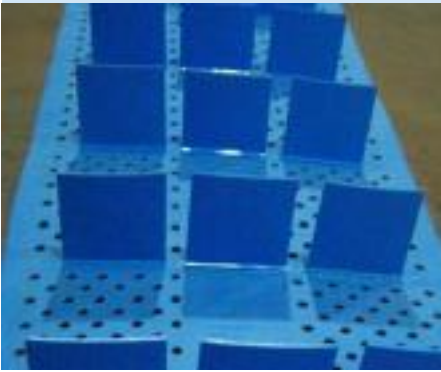

Perforated SuperDrive™
with Spaced Flights

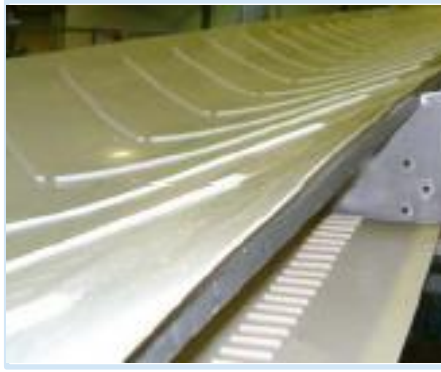

SuperDrive™ Trough Conveyor with
Chevron Flights

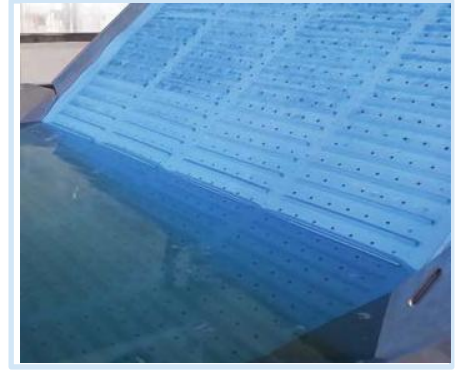

Perforated Mini DualDrive™ Belt

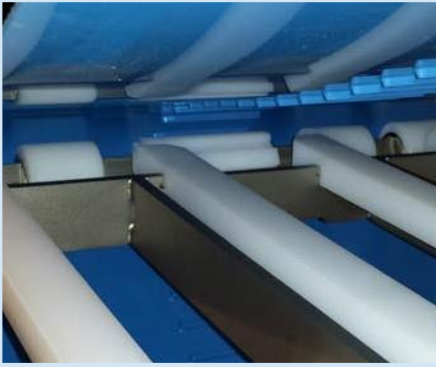

Mini SuperDrive™ Belt



Perforated DD-IRT Belt



SuperDrive™ Z-elevator with Flights,
Guides and Sidewalls



DualDrive™ with Impression Top IRT
Flights & Guides



SuperDrive™ with Flights Working
under Water



SuperDrive™ with Sidewalls
and Special Flights

The built-in guide mechanism and the new textured top keep your product safe and steady.

**We are excited to present our new
Positive Drive Belt: FMB-SD-MC**

- ✓ The fully extruded Mini Cleat (MC) top on our SuperDriveTM homogeneous material enhances the incline conveyance capability of carrying bulk product by up to 25 degrees.
- ✓ The MC profile prevents product rollback on the incline without requiring flights.
- ✓ Mini Cleat (MC) top eliminates the need for fabricated cleats.
- ✓ The fully extruded, integrated teeth of the Super DriveTM function as a positive drive system and serve as a built-in guide mechanism to reduce tension and off-tracking.
- ✓ The result is eco-friendly SuperDriveTM belts that allow for a drastic reduction in water usage as well as the conversion of precious lost time spent on cleaning to increased production time.
- ✓ SuperDriveTM belt with Mini Cleat (MC) top are a cutting-edge solution for the potato, meat, fruit, and cheese industries. Suitable applications include, but are not limited to, French fries, chicken cutlets, cold cuts, bacon, sliced peaches and pears, shredded cheese, and nuts.

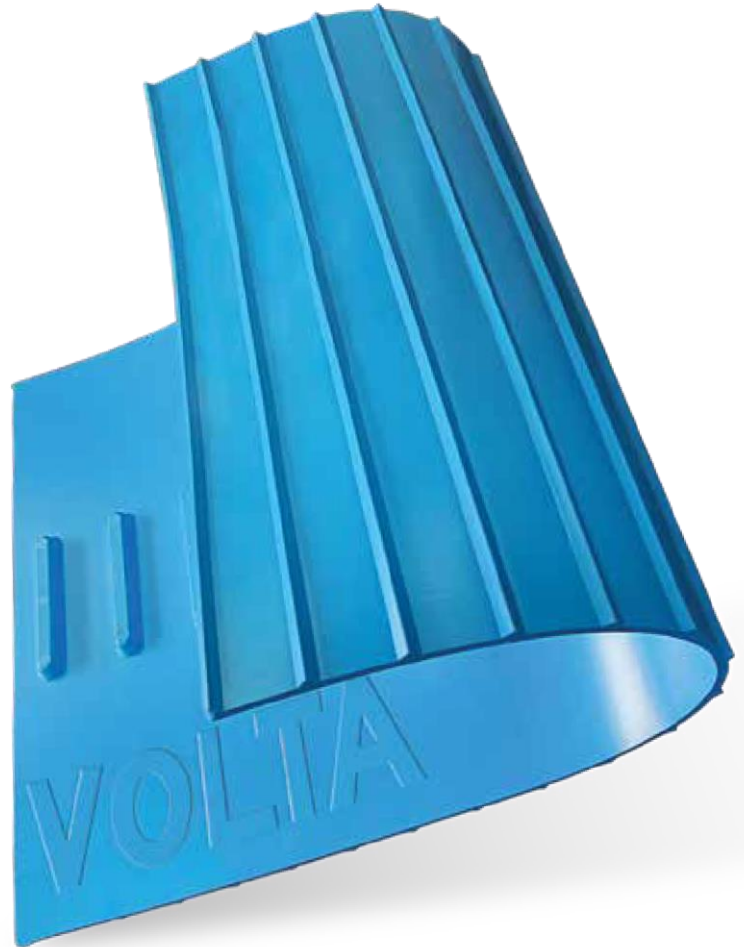

**Use this belt to keep your products
safe and steady and earn more
money than before.**

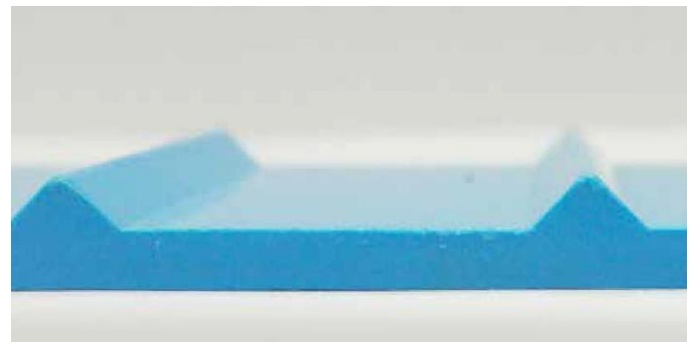

Molded BLUE Sprockets for DualDriveTM



Molded
 Drive Sprocket

Molded
 Tail Roller

Volta offers molded sprockets in blue Acetal for the DualDriveTM belts. These are offered in addition to the standard white and blue machined sprockets.

DualDriveTM Molded Sprockets

Number of Teeth	Drive Sprocket	Tail Roller
6T	DD-I-Sprocket-93.4mm/3.67"	DD-I-Tail Sprocket-84.3mm/3.32"
8T	DD-I-Sprocket-125.6mm/4.94"	DD-I-Tail Sprocket-116.5mm/4.59"
10T	DD-I-Sprocket-157.7mm/6.20"	DD-I-Tail Sprocket-148.5mm/5.85"

- Compatible with 40mm and 1.5" square bore shafts
- Light weight
- Have excellent chemical and abrasion resistance
- Easy to clean



The Next Step in Belting



Metal Detectable
Flat Belts

Conveying Solutions



Metal Detectable (MD) Volta belts for the food industry

As you are aware, consumer safety has become a prominent issue in recent years due to heightened public awareness, increasingly stringent legal regulations, and the challenging responsibility of managing an automated food processing line. The ever-changing demands and pressures for superior food safety are driven internally by managers along with external pressures from consumers, industry regulators, and global associations.

Often called “farm to fork”, the path from raw food to a finished and packaged product is one that has hazardous contact points. Before consumers have their food on their tables, that food has come into contact with harvesting equipment, slaughterhouses, freezers, cold storages, a wide array of transportation means, and various processing machinery. Although most contaminants (much of which is ferrous) are removed in early processing stages, trace contaminants can still remain in foods. Thus, metal detection is often used as a last line of defense in most processing facilities.

Food routinely makes contact with conveyor belting and with the widespread use of fragile modular belting, concerns arise over plastic contaminants being deposited into the flow of food due to wear and tear. Volta firmly stands behind the safety and stability of all Volta food grade belts as a solution for alternative inferior belting types. Our ultimate goal is to eliminate any concerns and fears held by processors and consumers regarding food safety.

Abraded by Frozen Food

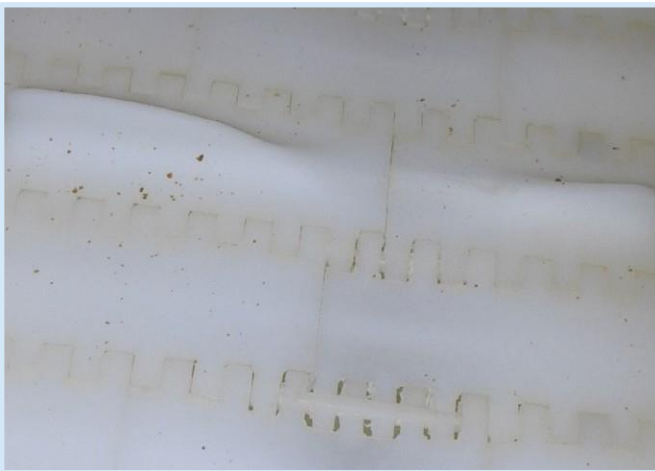

Broken cleats/flights

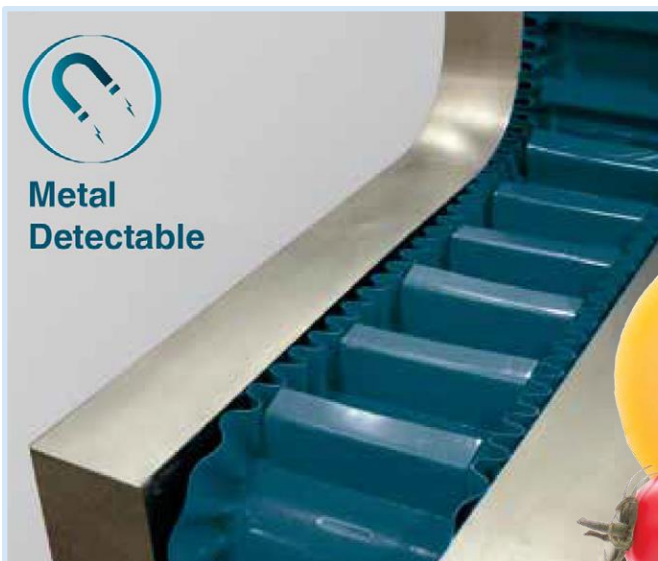
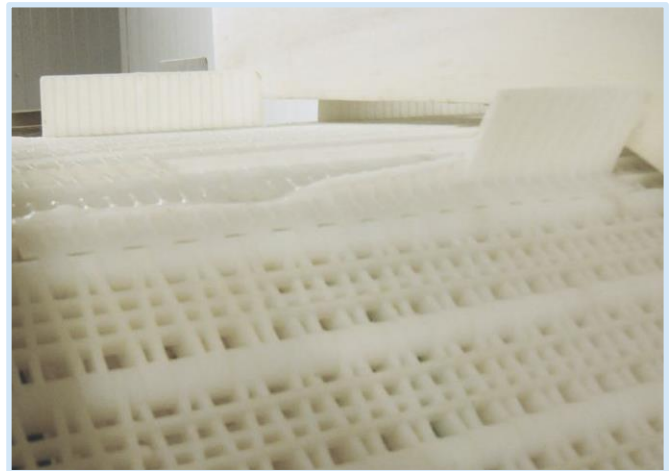

Metal detectable plastic is an important necessity to all types of food processors. Many would never consider allowing pens, electric ties, and plasters within the hygienic zone if they were not detectable.

While Volta Belting’s materials are resistant to cuts and breakage, food grade metal detectable belts have been developed to meet high demands and to give quality assurance and production teams the confidence in knowing that their products will meet the strictest food safety requirements.

Detectability is determined by contaminant type, size, the size of the detector’s aperture, the orientation of the detectable material, and the frequency at which the detector is calibrated. Small particles may pass undetected if the food product has a similar phase angle to the contaminant (dry and moist products produce different signals), or if the particle passes through the center of a sufficiently large detector.

Metal Detectable (MD) Positive Drive Belts												
Product & Color		Shore Hardness	Temperature Range	CoF UHMW (bottom)	Thickness		Minimum Pulley Diameter		Maximum Pull Force		Certifications	
					mm		mm	Inch	kg/cm	lbs/in		
SuperDrive™ Metal & Detectable Belt												
FMB-SD-MD	Blue 09		53D	-20°C to 60°C -5°F to 140°F	0.28	3		100	4	6	33.6	FDA/EU
FMB-SD-ITO50-MD	Blue 09		53D	-20°C to 60°C -5°F to 140°F	0.28	3		100	4	6	33.6	FDA/EU
DualDrive™ Metal Detectable Belt												
FMB-DD-MD	Blue 09		53D	-20°C to 60°C -5°F to 140°F	0.28	3		100	4	6	33.6	FDA/EU

Metal Detectable (MD) Food Conveying Belts												
Product & Color		Shore Hardness	Temperature Range	CoF UHMW (bottom)	Thickness		Minimum Pulley Diameter		Pull Force: Pretension 1%		Certifications	
					mm		mm	Inch	kg/cm	lbs/in		
Flat, Homogeneous Metal Detectable Belts												
FMB-MD	Blue 09		95A	-20°C to 60°C -5°F to 140°F	0.28	3		75	3	1.80	10.1	FDA/EU
Flat, Homogeneous Embossed Bottom Metal Detectable Belts												
FEMB-MD	Blue 09		95A	-20°C to 60°C -5°F to 140°F	0.20	2		50	2	0.80	4.5	FDA/EU
						3		75	3	1.20	6.8	
Flat, Homogeneous Impression Top Metal Detectable Belts												
FEMB-ITO50-MD	Blue 09		95A	-20°C to 60°C -5°F to 140°F	0.20	2		50	2	0.60	3.36	FDA/EU
						3		75	3	1	5.6	
FEMB-CT-MD	Blue 09		95A	-20°C to 60°C -5°F to 140°F	0.20	3		95	3 3/16	1.2	6.75	

Guidelines and Suggested Materials for the Fabrication of Metal Detectable (MD) belts:

- ✓ The Metal Detectable material (MD) should be treated as a separate family of materials in terms of fabrications.
 - ✓ Sidewalls: It is possible to weld Sidewalls from MD material (FMB-MD) with a thickness of 2mm only.
 - ✓ Flights: It is recommended to use MD material for flights – FMB-MD.
 - ✓ Guides: Use the VLB-MD guide for the Metal Detectable belts.
 - ✓ Electrodes: Use EVMB-MD electrode.
 - ✓ RoundFlex™ Lace: Item code LMD-R
- Endless Closure of Belts: Volta recommends joining the Metal Detectable (MD) Positive Drive belts with a butt weld using an FBW Tool.

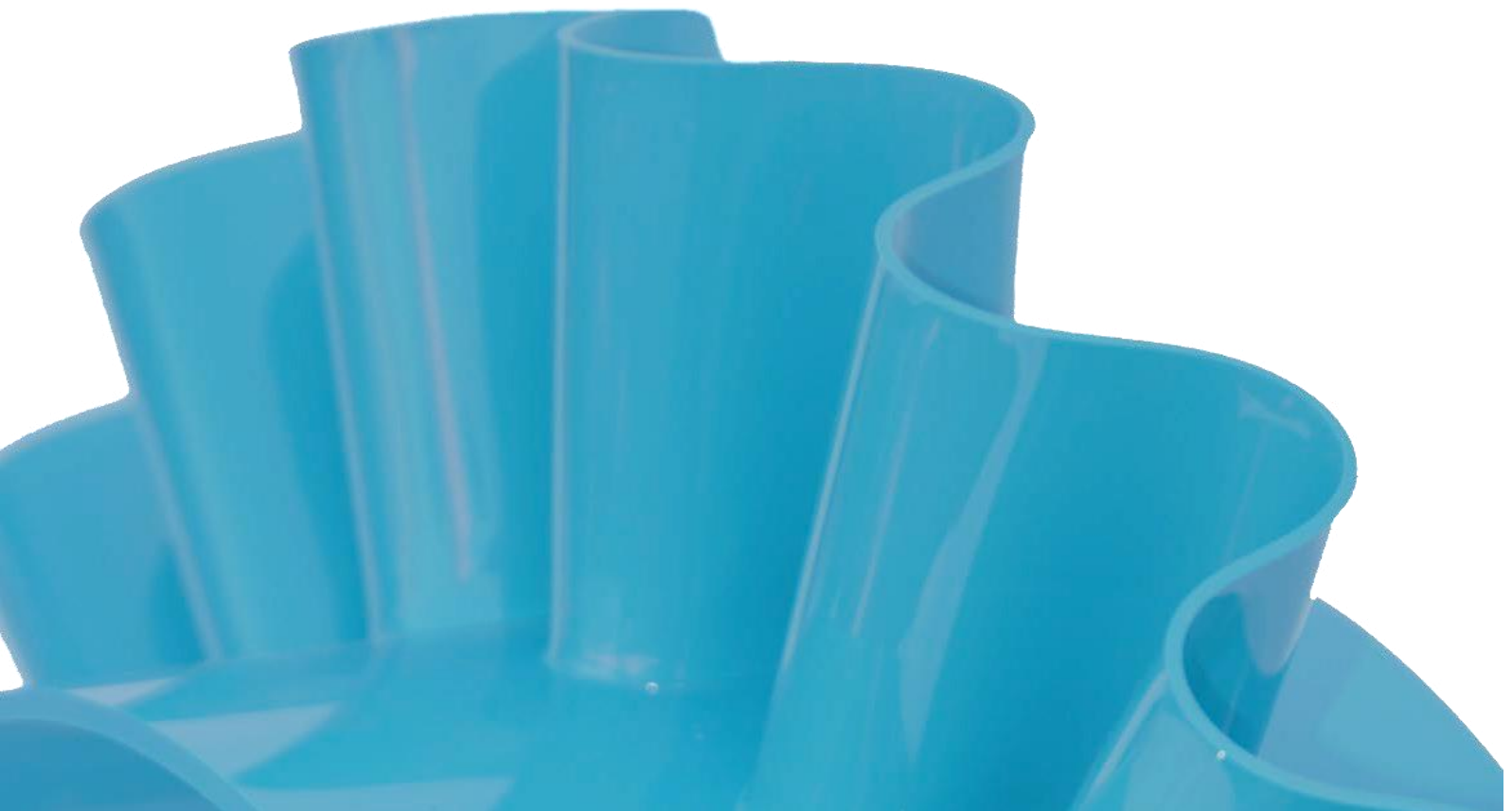



The Next Step in Belting

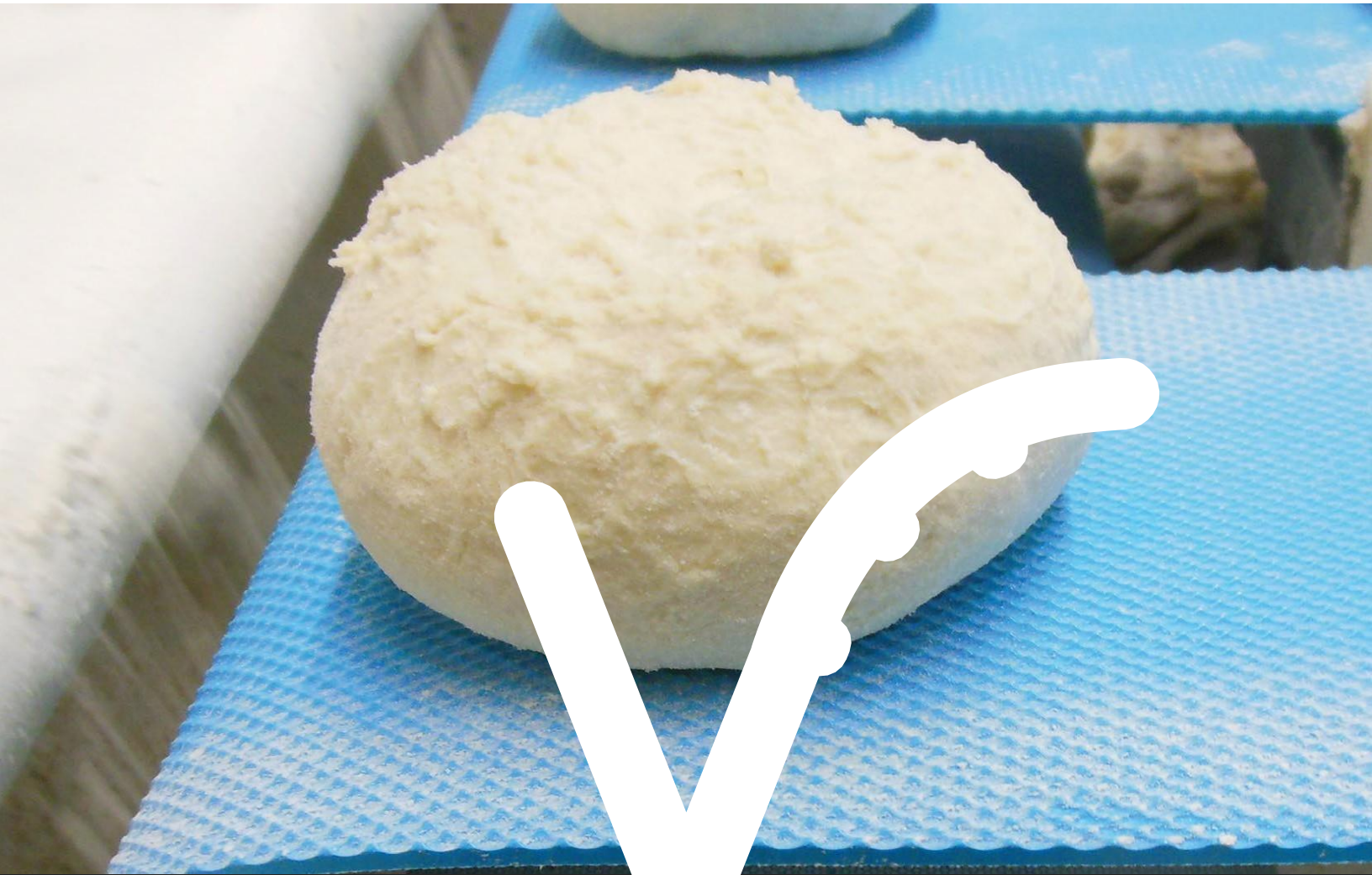

Aramid Cord Reinforced Flat Belts
Conveying Solutions



A food grade flat belt with special tensioning members fully sealed in a dense homogeneous material which has been tested for durability. Used, for example, where heavy or unevenly loaded products are carried. The Volta code for this Aramid cord reinforcement is ACR and the splicing method advised is a finger splice.



Aramid Cord Reinforced Flat Belt Range

Embossed Bottom Belt

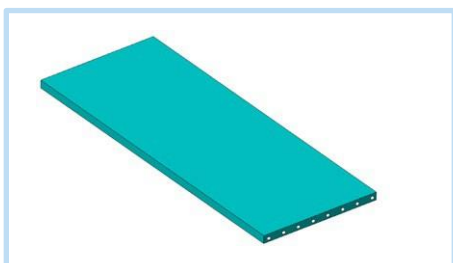

IST - Impression Saw Tooth

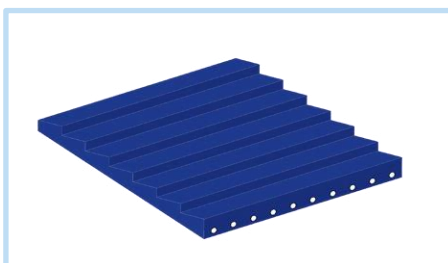

ITO50-Impression Top Oval

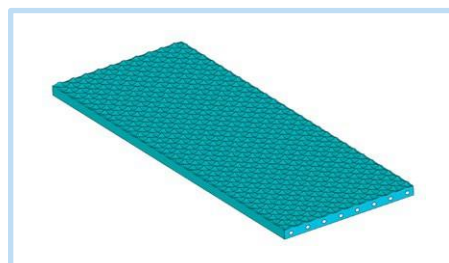

Aramid Cord Reinforced (ACR) Embossed Bottom Belts											
Product & Color		Shore Hardness	Temperature Range	Coefficient of Friction on S.Steel (Bottom)	Thickness	Minimum Pulley Diameter		Pull Force: Pretension of 0.2%		Certifications	
					mm	mm	Inch	kg/cm	lbs/in		
FELB-ACR	Blue	80A	-40°C to 50°C -40°F to 120°F	0.45	2.5	20	0.79	4	22.40	FDA/EU	
Aramid Cord Reinforced (ACR) Impression Top & Embossed Bottom Belts											
FELB-ACR-ITO50	Blue	80A	-40°C to 50°C -40°F to 120°F	0.45	2.5	20	0.79	4	22.40	FDA/EU	
FELB-ACR-ITO50	Blue 02	80A	-40°C to 50°C -40°F to 120°F	0.45	2.5	20	0.79	4	22.40	FDA/EU	
FELB-ACR-IST	Blue 02	80A	-40°C to 50°C -40°F to 120°F	0.45	4*	35	1.38	4.2	23.40	FDA/EU	
Low Temperature (LT) Aramid Cord Reinforced (ACR) Impression Top & Embossed Bottom Belts											
FELB-ACR-ITO50-LT	Blue 15	80A	-40°C to 50°C -40°F to 120°F	0.45	2.5	18	0.70	4	22.40	FDA/EU	
FEMB-LT-ITO50-ACR	Blue 15	95A/46D	-35°C to 50°C -30°F to 120°F	0.25	2.5	40	1.57	4	22.40	FDA/EU	

Note: * FELB-IST-ACR – Base belt thickness = 2mm // Total belt thickness including Saw tooth impression top = 4mm.

** Available belt width: 1524mm/60inch-standard or 2032mm/80inch. Please contact Volta Belting representative for additional informations. Pull force in table relates to a finger splice weld 20x50 mm. The calculation takes into account the weld splice which has strength of 28kg/cm. Note that various finger splice methods and different tools can result in differing belt strengths

Guidelines for Finger Splice Welding of the Volta Aramid Cord Reinforced (ACR) Belts

The Finger splice, with its increased contact area overlapping reinforcement cords, ensures the best weld in terms of belt strength.

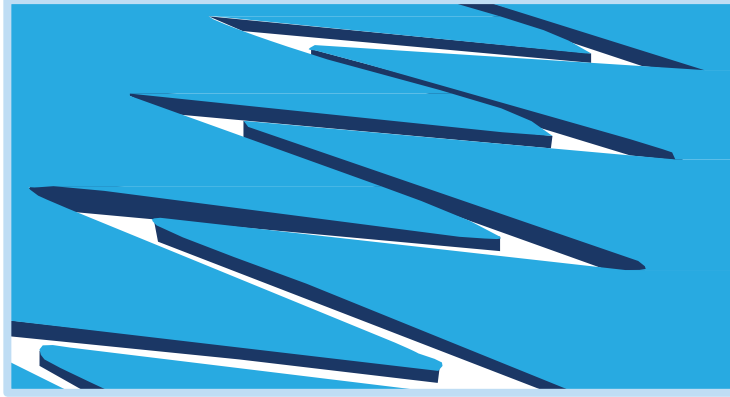

Important Note: All information in the finger splice instructions is to be used as general guidelines only, based on experience from service centers using a variety of equipment. It has been noted that the exact temperature of a specific welding bar and the pressure required will vary from press to press or even on the same press when used in a workshop and then on site. Prior to first use, it is recommended to run a small set of trials to calibrate a given press. Prior to repeated use in a different environment and/or with a different thickness or texture, a test should be made to confirm the quality of weld is consistent and that every splice is hermetically closed and free from bubbles and cracks.

For Splicing "L" Material Belts:

- | After switching on the press, wait for both the top and bottom platens to heat to 180°C.
- | When cutting the belt to the finger pattern, cut away any protruding Aramid fibers. Do not attempt to drill out the ends of these fibers into the belt surface.
- | Place belt in position on heated area. Do not leave for any length of time without continuing the operation.
- | Place an appropriate silicone pad across the top side of the belt in order to preserve the original belt surface (smooth or textured) as far as is possible.
- | Apply 2 Bar of pressure for 4 minutes.
- | Wait for the belt to cool down in the press (approx. 15 minutes) and then release.

For Splicing "M-LT" Material Belts

- | After switching on the press, wait for both platens to heat to 180°C.
- | When cutting the belt to the finger pattern, cut away any protruding Aramid fibers. Do not attempt to drill out the ends of these fibers into the belt surface.
- | Place belt in position on heated area. Do not leave for any length of time without continuing the operation.
- | Place an appropriate silicone pad across the top side of the belt in order to preserve the original belt surface (smooth or textured) as far as is possible.
- | Apply 2.5 Bar of pressure for 6 or 7 minutes.
- | Wait for the belt to cool down in the press (approx. 20 minutes) and then release.

Benefits:

- ✓ Reinforced belts with no fabric exposed
- ✓ No fraying, no delamination
- ✓ Eliminate contaminated reinforced fabric which is difficult to clean
- ✓ Fully extruded
- ✓ Food approved
- ✓ Compatible with HACCP principles
- ✓ Permits versatile applications such as soft base belts on small pulley diameters
- ✓ Can replace reinforced belts in wet applications where the sealed reinforcement hinders contamination and in bakery applications using flour
- ✓ High resistance to oils, fats and hydrolysis





The Next Step in Belting

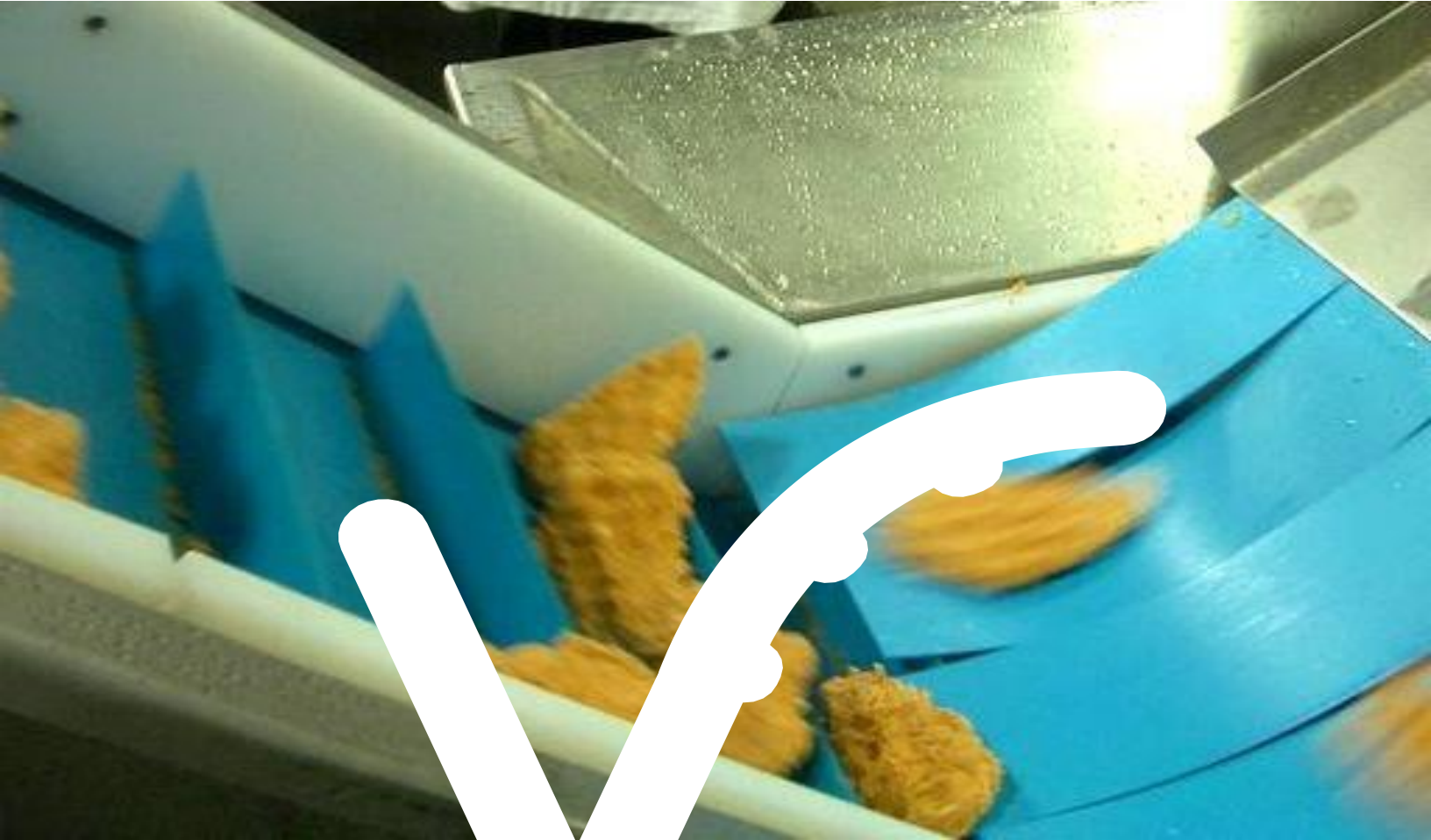

Food Grade Accessories
Conveying Solutions



Volta food grade materials possess mechanical characteristics which make them ideally suited to static elements such as funnels or chutes. These elements are common in free fall of food products and chemicals and, when fabricated from conventional, inflexible materials such as polycarbonate or steel, can be hazard points or elements of concern in production for a number of reasons;

- | Hard elements causing damage to product in free fall
- | Elements from inflexible materials can jam when (irregular and bulky) product flow is at maximum
- | Polycarbonate elements are often cracked when removed for cleaning and refastened with bolts by maintenance staff
- | With solids, noise levels can be high
- | Bolts and fasteners can be difficult to open
- | Steel elements do not offer visibility into the product flow
- | Low cleanability



✓ Volta uses homogeneous food grade materials, including transparent and translucent conform to designs for funnels, chutes, pipes and similar elements to eliminate all the above problems. Flanges can be welded on to facilitate the fixing of the Volta funnels in the flow line.

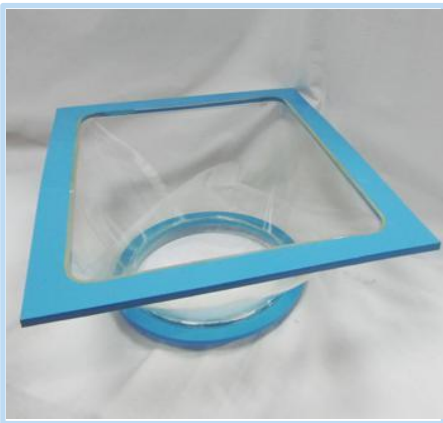

Square to round flanged funnel



Double funnel



Double-flanged funnels

Base Materials used for funnels

Product & Color			Shore Hardness	Temperature Range	Thickness	Certifications
FMB	Blue		95A / 46D	-30° C to 70° C / -20° F to 158° F	2	FDA/USDA/EU
FMW	Beige				2.5	
FMWC	Clear				3	

✓ All elements are custom-made and can even be fitted and welded on site where measurements are difficult or inaccurate such as for hopper linings.

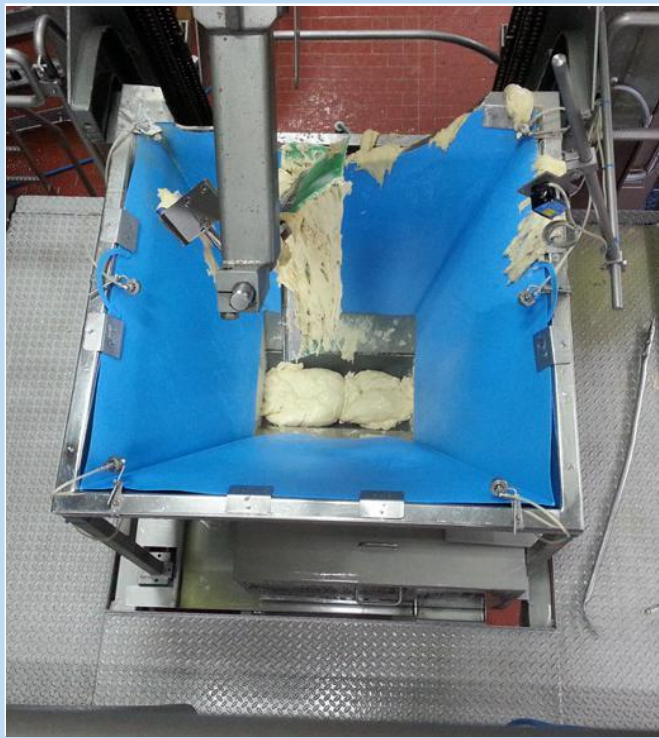

Hopper

✓ Hammocks are used to reduce noise and damage to sensitive products in freefall - examples range from vegetables to hard boiled sweets.



Hammock

✓ Simple flat pieces are available for use on tables, intake chutes and as skirting and scrapers. Skirting can be used as a simple means of containment and is an effective means of protecting conveyor features such as bearings and supports. Product is not lost and will not fall into the conveyor bed and support structure.



Chute Installed



Skirting



Sorting Table



Scraper

The use of correctly selected Volta material will not groove or damage the moving Volta conveyor belt.

Volta - Food Grade Accessories



Custom made funnels



Pipes



Special funnel

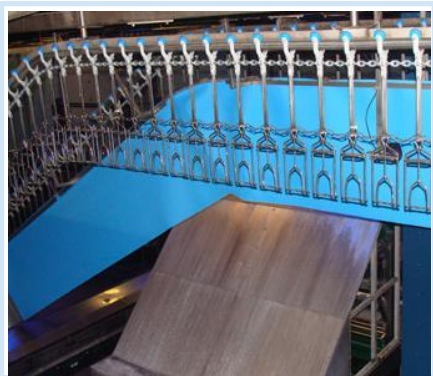

Skirting

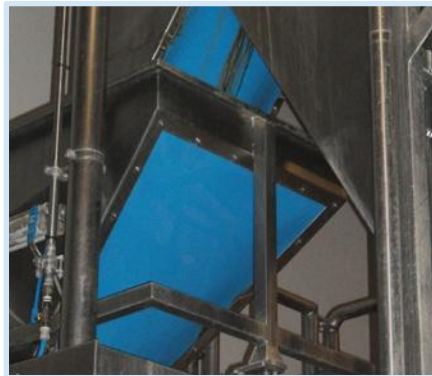

Chute lining

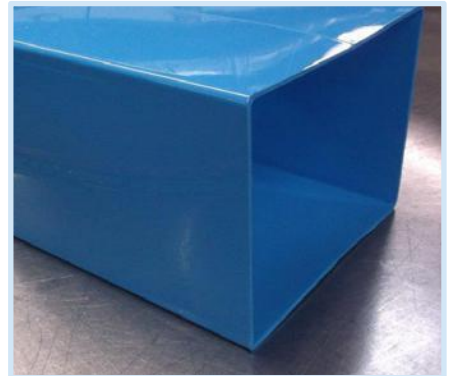

Squared-off tube



Funnels from Volta material



Double funnel



Silo funnel



Simply Safe & Hygienic
Conveying Solutions

/// Motech

Governments & Consumers Demand More Stringent Safety Procedures from Farm-to-Fork

The issue of food hygiene has become an issue of paramount importance in food processing. Pressure has come from a number of different directions; a change in eating habits in industrialized and developing nations away from fresh, market-sourced foodstuffs; the conglomeration of the food industry around the world; the tenuous supply chain that exists for many products and a general increase in awareness, health culture and the resulting proliferation of legislation and regulations.

Consumer awareness has resulted in governments being lobbied to introduce more stringent controls on food safety and incidents of recalls and even food poisoning due to contaminated product have risen.

Independent organizations are beginning to examine the concept of 'food grade' which does not in most cases cover the belt production technology but merely the plastic from which it is made. The most recent is the EHEDG organization which has, for the first time, brought some 'food grade' belt types into question.

Food manufacturers are keenly aware of the need to reduce their liability to product claims and food suppliers such as supermarkets go to great lengths to audit the products they stock their shelves with and will visit processors at all levels to ensure compliance with safety standards and good practice.

Of all the machinery parts and processing devices that come into direct contact with food at all stages of processing, from raw treatments, through washed and frozen to cooked, conveyors are routinely employed to enable factories to increase throughput. The surface of the conveyors is one of the only non-processing elements to touch food prior to packaging and, as such, is in need of extra care and attention when it comes to improving and maintaining hygiene levels and reducing the risk of contamination.

Using Conveyor Belts as part of a Food Safety Strategy

Conveyor belts should exhibit the following characteristics:

- | **Strong and consistent (abrasion resistant):** to handle products of various sizes, weights, shapes and consistencies (including sharp elements) without displaying wear and tear that turns the belt into a hazard point.
- | **Non-porous material:** impermeable to fats, liquids, and chemicals and not prone to harbor bacteria or other micro organisms.
- | **Non-Stick surface:** preventing product from sticking to the conveyor belt and thereby reducing the repeated contact of dirt with material subsequently conveyed.
- | **Homogeneous:** made from dense (extruded) material with no fabrics to fray or soak up fluids and cleaning agents. No links, joints and pins which harbor bacteria and involve long and frequent chemical soaks to bring back to working condition.
- | **Easy to operate and maintain:** a positive drive belt with an off-tracking system such as Volta's SuperDrive™ can reduce the amount of working parts in a conveyor and allow for an open and hygienic conveyor design. Upgrading conveyors will actually reduce the cost of ownership as well as provide a safer processing environment.
- | **Easy to sanitize:** Homogeneous belts offer the fastest wash down regimes with no removal of belts from conveyors. Water consumption and labor is saved; the environmental cost is low and production time is freed up.

As a manufacturer of food grade conveyor belts with over 50 years of industry experience, Volta has designed belts that conform to all these considerations and do not just meet the expectations and demands of food processors, but exceed them. Volta offers tested and certified food grade belts for all food processing needs and allow for true compliance with HACCP principles.

For more information on HACCP visit the official site at www.haccpalliance.org

For download of EHEDG Guideline 43 visit www.ehedg.org

Simply Safe & Hygienic

Simply Hygienic

Volta Belting has been developing and designing conveyor belting products since 1964. Volta's thermoplastic elastomeric (TPE) food grade belts fully comply with the strictest hygiene requirements of the food industry and are used in thousands of installations worldwide.

Volta's hygienic belting technology is known for its versatility, durability and, above all, its hygienic safety. It offers the largest range of materials and surface textures and supports state of the art fabrications which are designed with preventing product residue and bacteria traps.

The materials are all extruded and can be welded piece to piece by heat or HF welding, eliminating the use of adhesives and giving a solid unbreakable bond. The features which are welded on, such as flights, guides and side walling, will not detach or fragment which this renders the need for metal detectable material obsolete. The positive drive systems, especially the SuperDrive™, are designed to make permit the flushing out of the bottom side when cleaning and the teeth are formed as part of the extrusion and not welded-on or machined (inferior production techniques that can make the teeth a hygienic hazard point by trapping dirt and fluids).

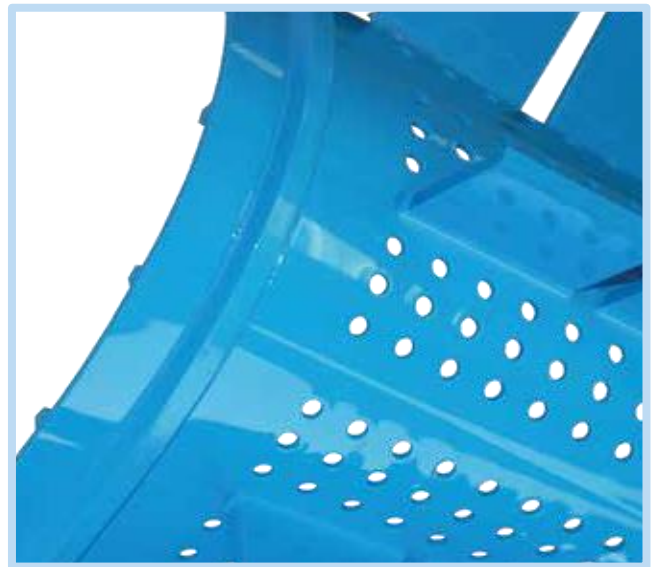
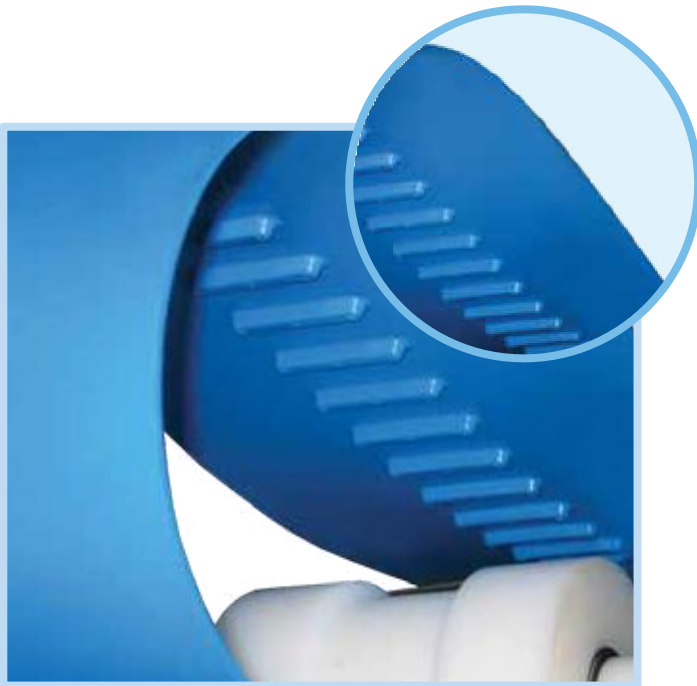

Material Quality

Volta belts outperform conventional belt types for hygienic stability:

- | Produced from dense TPE with resistant properties suited to difficult conditions: water, oils, fat, cold and freezing temperatures. The belts will not crack, delaminate or deteriorate over time.
- | Smooth non-porous surfaces which repel bacteria.
- | Especially strong and thick belts which can convey heavy loads, handle accumulation and take impact from problematic material and food waste.
- | Suited to Volta's in-house hygienic fabrications.
- | Easy to clean (wash down only; no soaking), keeping water consumption and handling time to a minimum.
- | Complies with EU, FDA and USDA regulations. Consistent with EHEDG Guideline 43.

SuperDrive™ - the World's Best Hygienic Conveyor Belt

SuperDrive™ is the most hygienic positive drive belt on the market. It uses all of the advantages of the TPE materials and the fabrication system common to Volta's other belts and goes further.

The belt is designed with integrally extruded teeth on the underside of the belt which have the safest and most reliable design for positive drive which can work in or under water and with humid and greasy foodstuffs. The teeth are sued to prevent off-tracking. Asides from the impressive mechanical capabilities, the SuperDrive™ teeth are the only positive drive teeth designed to facilitate washing and even allow trapped product to flush out during production to minimize the accumulation of fallout.

The belts are ultra-hygienic and also allows new standards of hygiene to be adopted in conveyor construction by allowing streamlined and minimalistic conveyor designs, that, when coupled with superior materials and finishing by a competent OEM, give the most advanced hygiene system available in the world.

Contrasting Volta's Hygienic System with Older Technologies

The belting industry still offers two main alternative systems: fabric coated belts ("ply" belts) and modular belts. The use of both these types has been called into question by EHEDG Guideline 43. Ply belts require sealing on the edges and underneath as well as frequent inspection; modular belts are not considered hygienic under any circumstances.

Fabric coated belts fray easily and are the fabric layers, overlaid with thin deposits of TPU, PVC or rubber coating crack on impact, from changes in humidity and temperature and from exposure to water, oils and fats. They are prone to delaminate at the joints from even moderate wear and in general across the surface from contact with abrasive materials such as salts, seasonings, frozen goods, bone fragments and the like. Not only exposed fabric layers but even light scratching can expose cavities inside the plastic which form breeding grounds for bacteria and micro-organisms and severely reduce belt cleanability.



Modular Belts have been widely sold to the food industry for over a decade; their overall hygienic condition and cleanability is not suited to food processing. From day one, modular belts cannot be cleaned effectively. Modular belts are composed of moving parts which are brittle and easily damaged and can enter the product flow unnoticed and untraced. The joints and pins and shaped link plates offer over 30% extra surface area, much of which is inaccessible to normal sanitation practices. Cleaning regimes are understandably stricter with such belts and the hidden cost of maintaining them in good condition makes them expensive. Coupled with their propensity to break or wear, the frequent replacement of parts makes them the most expensive and least cost-effective alternative available as well as being hygienically questionable at best.

Simply Safe & Hygienic

Three steps to clean your belt:

1 Clean the belt on the conveyor

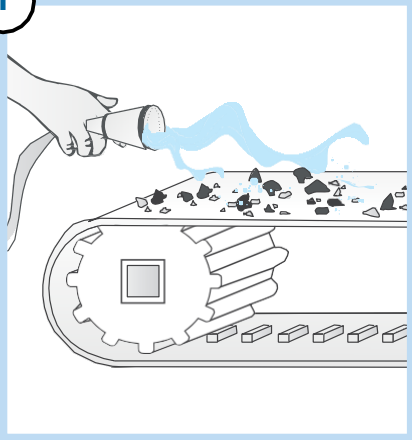

2 Brush the belt on the conveyor

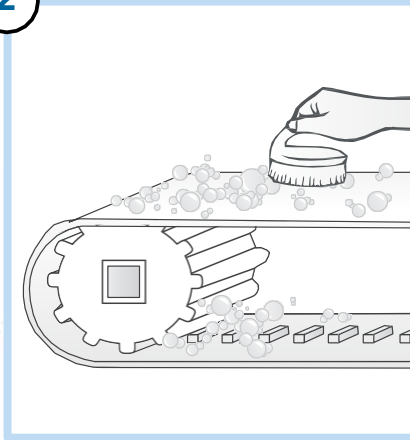

3 Wash the belt with water

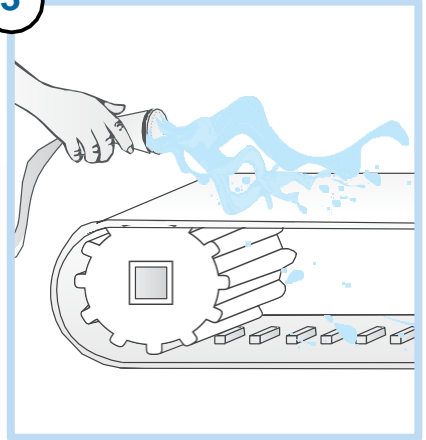

This is what they are saying about us

End Users' Reports on Volta's Hygienic Advantages

"We changed over our last non-Volta modular belt in 2011 to SuperDrive™. That was the last weak point in the factory."

QA Manager, Australian Dry Fruit Company

"We managed to increase shelf life by 25% on a Volta Z conveyor. As we do the logistic shipping across Europe, this is a major saving in fuel, manpower and lost product."

Salad Processor Plant in the South of Italy

"In 2010 we installed Volta's three-feed conveyor. We couldn't believe the quick change over time from batch to batch –it came down to under 10 minutes!"

Multinational Food Processing Plant in France

"We installed SuperDrive™ belts in place of modular and this gave us a saving in electricity, lower decibel counts, and fewer maintenance issues with motors, less waste and a cleaner product. I can bring my customers into the factory now with a clear conscience."

Indian Seafood Processor, Mumbai

Quality & Food Safety

Standards

Volta Belting has implemented and maintains a Quality Management System (QMS) that is in compliance with ISO 9001:2008 requirements for the production of conveyor belts and conveyor belting products.

Volta Belting's positive drive and food-grade belting comply with the following international standards:

- ✓ **USDA** Dairy Equipment Review Guidelines
- ✓ **USDA - NSF/ANSI/3-A 14159-3-2014** Hygiene Requirements for the Design of Mechanical Belt Conveyors Used in Meat and Poultry Processing
- ✓ Requirements of Code of Federal Regulations (**CFR21**) **USDA FDA** article 21 CFR 177.2600
- ✓ **European Regulation (EU)** No.-10/2011 amended by 2017/752, 1935/2004 and 2023/2006
- ✓ German Regulation BfR XXI

Associations

Volta Belting is a member of these prestigious professional industry organizations.



EHEDG (European Hygienic Engineering and Design Group)



NIBA (National Industrial Belting Association)

Volta manufactures its food grade conveyor belts at its production facility, which supports a sizeable R&D unit. The company has distribution centers in Europe, the USA, India and the Far East to serve its global markets, locally. Find out more about us or contact us for sales & service support center nearest you.

Volta Impression Top Collection

